

CITY OF DAYTON

STANDARD DETAIL PLATES

NOTES:

1. STANDARD DETAILS PLATES ARE UPDATE ANNUALLY. LATEST VERSION WILL BE ENFORCED.
2. REFERENCE ON CITY PLATES ARE TO MNDOT 2025 EDITION SPECIFICATIONS.



2026 DETAIL PLATES
REV.1

COVER

LAST REVISION:
DEC 2025

PLATE NO.
COVER-01

CITY
PLATE
NO.

INDEX

SECTION 1 - STREETS

STR-01	CURB AND GUTTER
STR-02	CONCRETE CURB AND GUTTER TRANSITION
STR-03	MOUNTABLE CURB AND GUTTER CONSTRUCTION AT CATCH BASIN
STR-04	B618 CURB AND GUTTER CONSTRUCTION AT CATCH BASIN
STR-05	RESIDENTIAL STREET SECTION
STR-05A	TYPICAL RESIDENTIAL STREET DIMENSIONS
STR-06	URBAN COLLECTOR STREET SECTION
STR-06A	RURAL COLLECTOR STREET SECTION W/ AGGREGATE SHOULDER
STR-07	TYPICAL PRIVATE STREET SECTION, NO PARKING
STR-08	TYPE I CUL-DE-SAC WITH ISLAND FOR A 50' R/W AND A 60' R/W
STR-09	CONCRETE VALLEY GUTTER
STR-10	RESIDENTIAL CONCRETE DRIVEWAY APRON (B6 TYPE CURB)
STR-11	RESIDENTIAL CONCRETE DRIVEWAY APRON (MOUNTABLE TYPE CURB)
STR-12	RESIDENTIAL CONCRETE DRIVEWAY APRON WITH SIDEWALK (B6 TYPE CURB)
STR-13	RESIDENTIAL CONCRETE DRIVEWAY APRON WITH SIDEWALK (MOUNTABLE TYPE CURB)
STR-14	COMMERCIAL CONCRETE DRIVEWAY APRON
STR-15	COMMERCIAL CONCRETE DRIVEWAY APRON WITH SIDEWALK
STR-16	SIDEWALK/BIKE PATH CURB RAMP
STR-17	SIDEWALK/BIKE PATH CURB RAMP - GENERAL LOCATION
STR-18	DOUBLE SIDEWALK/BIKE PATH CURB RAMP - GENERAL LOCATION
STR-19	TYPICAL BIKE PATH AND SIDEWALK SECTIONS
STR-20	UTILITY AND LANDSCAPE LAYOUT
STR-21	FUTURE THROUGH STREET SIGN
STR-22	PRIVATE DEVELOPMENT TURNAROUND
STR-23	SEWER AND WATER SERVICE LOCATION STAMP IN CURB
STR-24	TYPICAL RESIDENTIAL DRIVEWAY SECTIONS
STR-25	CURB RAMP FOR CENTER ISLAND
STR-26	FIRE APPARATUS ACCESS ROAD (FIRE LANE) SECTION
STR-27	CU-DE-SAC ISLAND WITH PLANTED CENTER ISLAND
STR-28	TEMPORARY CUL-DE-SAC
STR-29	RESIDENTIAL STREET LIGHTING
STR-30	RESIDENTIAL DRIVEWAY AND GARAGE APRON
STR-31	PERMANENT BARRICADE

SECTION 2 - SANITARY SEWER

SAN-01	SANITARY SEWER MANHOLE
SAN-02	SANITARY SEWER MANHOLE WITH REINFORCED TOP SLAB
SAN-03	SANITARY SEWER DROP INLET MANHOLE
SAN-04	WATERTIGHT CASTING FOR SANITARY SEWER MANHOLE
SAN-05	TRUNK SANITARY SEWER MANHOLE
SAN-06	SANITARY SEWER SERVICE CONNECTION



2026 DETAIL PLATES
REV.1

INDEX

LAST REVISION:
DEC 2024

PLATE NO.
INDEX-01

CITY
PLATE
NO.

INDEX

SECTION 3 - WATER MAIN

WAT-01	HYDRANT DETAIL
WAT-01A	DOUBLE PUMPER PACER HYDRANT DETAIL
WAT-01B	STANDARD PACER HYDRANT DETAIL
WAT-02	GATE VALVE AND BOX INSTALLATION
WAT-02A	BUTTERFLY VALVE AND BOX INSTALLATION
WAT-03	WATER MAIN WETTAP
WAT-04	CONCRETE THRUST BLOCKING
WAT-05	WATER MAIN OFFSET
WAT-06	TYPICAL GATE VALVE LAYOUT
WAT-07	IRRIGATION SYSTEM TAP, METER AND BACKFLOW PREVENTOR ASSEMBLY DETAIL
WAT-08	PLUG OR CAP WITH BLOWOFF

SECTION 4 - STORM SEWER

STO-01	STORM SEWER JUNCTION MANHOLE
STO-02	STORM SEWER MANHOLE WITH REINFORCED TOP SLAB AND SUMP
STO-03	CATCH BASIN MANHOLE
STO-04	CATCH BASIN MANHOLE WITH SUMP
STO-05	2' X 3' CATCH BASIN
STO-06	DOUBLE CATCH BASIN: CATCH BASIN MANHOLE WITH 2' X 3' CATCH BASIN
STO-07	CATCH BASIN MANHOLE IN GREEN SPACE
STO-08	FLARED END SECTION AND TRASH GUARD
STO-09	RIPRAP AT OUTLETS
STO-09A	STORM SEWER PILING & CONCRETE END SECTION
STO-10	TYPICAL POND EOF
STO-11	ENERGY DISSIPATOR AND TRASH GUARD
STO-12	"MINI-TEE" MANHOLE
STO-13	PVC (RIGID) PERFORATED DRAINTILE SWALE INSTALLATION
STO-13A	ROAD SUBDRAIN
STO-14	RURAL RESIDENTIAL DRIVEWAY AND CULVERT
STO-15	STORM SEWER SKIMMER STRUCTURE
STO-16	STORM SEWER SKIMMER STRUCTURE WITH CONCRETE BAFFLE WALL
STO-16A	OUTLET CONTROL STRUCTURE
STO-17	TYPICAL BENCH AND MAINTENANCE ACCESS DETAIL
STO-18	PVC DRAINTILE CLEANOUTS
STO-19	SUMP SERVICE CONNECTION
STO-20	BACKYARD DRAIN TILE FOR SUMP CONNECTIONS

SECTION 5 - BEDDING

BED-01	BEDDING METHODS FOR PLASTIC PIPE
BED-02	BEDDING METHODS FOR RCP AND DIP
BED-03	IMPROVED FOUNDATION FOR RCP AND DIP

CITY
PLATE
NO.

INDEX

SECTION 6 - SERVICES

SER-01A	SEWER AND FUSED WATER SERVICE CONNECTIONS
SER-01B	SEWER AND COMPRESSION WATER SERVICE CONNECTIONS
SER-02	SERVICE RISER
SER-03	PVC SERVICE LINE CLEANOUTS
SER-04	SERVICE CONNECTION TO RCP
SER-05	RESIDENTIAL SEWER AND WATER SERVICE CONNECTIONS FROM STUB TO HOUSE
SER-06	NON-RESIDENTIAL SEWER AND WATER SERVICE CONNECTIONS FROM STUB TO BUILDING
SER-07	WATER SERVICE LAYOUT FOR BUILDINGS REQUIRING FIRE SUPPRESSION

SECTION 7 - EROSION CONTROL

ERO-01A	SILT FENCE - MACHINE SLICED
ERO-01B	SILT FENCE - HEAVY DUTY
ERO-01C	SILT FENCE - STANDARD
ERO-01D	SILT FENCE - J-HOOK
ERO-02	EROSION CONTROL BLANKET INSTALLATION
ERO-03	FLOATING SILT CURTAIN
ERO-04A	INLET PROTECTION - SILT BOX FOR CATCH BASIN BEFORE ROAD CONSTRUCTION
ERO-04B	INLET PROTECTION - ROCK FILTER FOR CATCH BASIN DURING CONSTRUCTION
ERO-04C	INLET PROTECTION - CATCH BASIN INSERT AFTER PAVING
ERO-04D	INLET PROTECTION - SILT BOX FOR BEEHIVE CASTING
ERO-05A	DITCH CHECK 3D VIEW FOR 5B, 5C AND SPACING
ERO-05B	DITCH CHECK - ROCK WEEPER AND BIO WEEPER
ERO-05C	DITCH CHECK - SMALL CHECK DAM AND LARGE CHECK DAM
ERO-05D	DITCH CHECK- MACHINE SLICED SILT FENCE
ERO-05E	DITCH CHECK - TRIANGULAR SILT DIKE
ERO-06	FILTER LOG DITCH CHECK
ERO-07	CONSTRUCTION ENTRANCE - ROCK
ERO-08A	TEMPORARY SEDIMENTATION BASIN - SKIMMER OUTLET
ERO-08B	TEMPORARY SEDIMENTATION BASIN - STANDPIPE OUTLET
ERO-09	TEMPORARY SEDIMENT TRAP
ERO-10	SLOPE TRACKING

SECTION 8 - GENERAL

GEN-01	STRUCTURE MARKER SIGNS
GEN-02	INSULATION DETAIL
GEN-03	SEAL COAT SIGNS
GEN-04	REGULATORY SIGN DETAIL
GEN-04A	REGULATORY SIGN DETAIL CONCRETE
GEN-05	NO PARKING SIGNS
GEN-06	STREET SIGN DETAIL
GEN-06A	PRIVATE DRIVE SIGN - RESIDENTIAL
GEN-06B	PRIVATE DRIVE SIGN - RURAL



2026 DETAIL PLATES
REV.1

INDEX

LAST REVISION:
DEC 2024

PLATE NO.
INDEX-03

CITY
PLATE
NO.

INDEX

SECTION 8 - GENERAL (CONT.)

GEN-07	SHRUB PLANTING DETAIL
GEN-08	DECIDUOUS TREE PLANTING DETAIL
GEN-09	CONIFEROUS TREE PLANTING DETAIL
GEN-10	WETLAND BUFFER, CONSERVATION AREA AND CITY NATURAL AREA SIGNS
GEN-11	TYPICAL PARALLEL PARKING AND STALL DETAILS
GEN-12	QUALITY SERVICE LOCATES (GPS - UTILITY DATA COLLECTION)
GEN-13	DEFLECTION TEST PIPE MATERIAL AND MANDREL SIZE
GEN-14	TESTING REQUIREMENTS
GEN-15	CERTIFICATE OF SURVEY AND GRADING AS-BUILT REQUIREMENTS



2026 DETAIL PLATES
REV.1

INDEX

LAST REVISION:
OCT 2024

PLATE NO.
INDEX-4

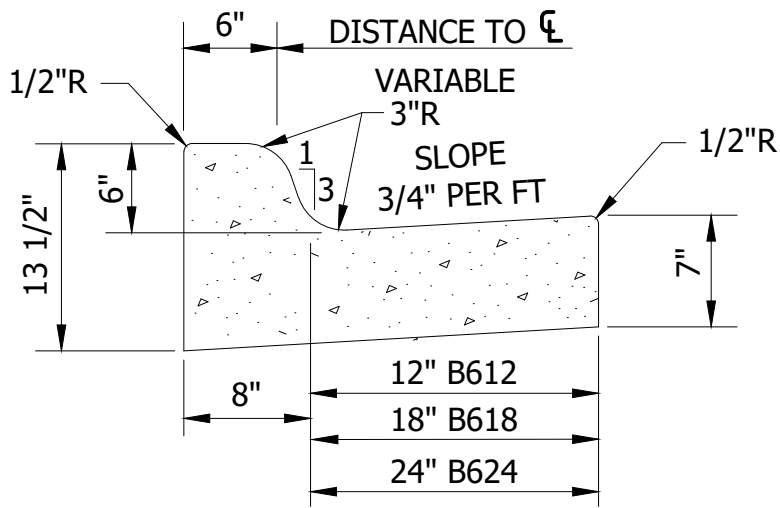

MNDOT B612
MNDOT B618
MNDOT B624

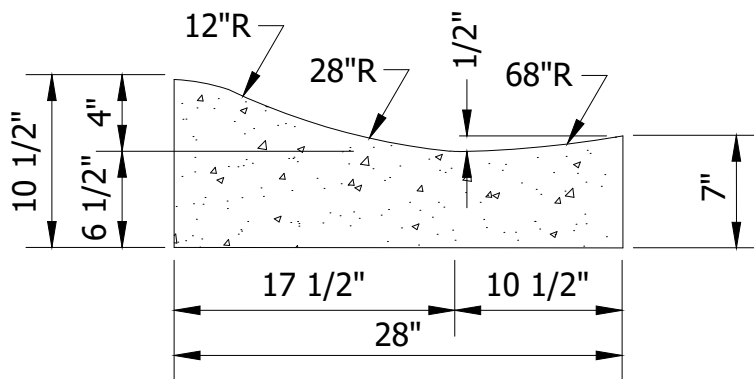

MOUNTABLE

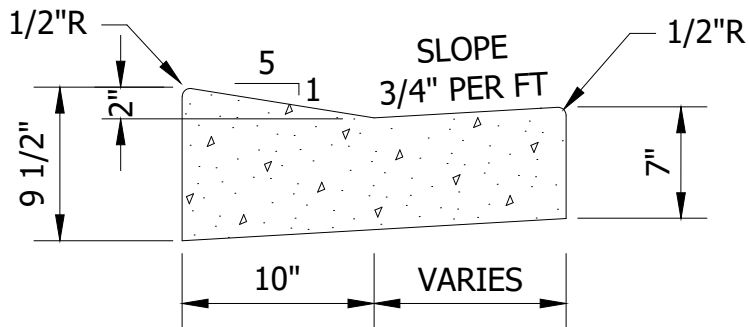

STANDARD SECTION
THROUGH DRIVEWAY

NOTE:

- ① PLACE A "W" , "S" , AND "CO" STAMP PER CITY PLATE #STR-23 ON FACE OF CURB WHERE CURB & GUTTER CROSSES A WATER OR SEWER SERVICE.

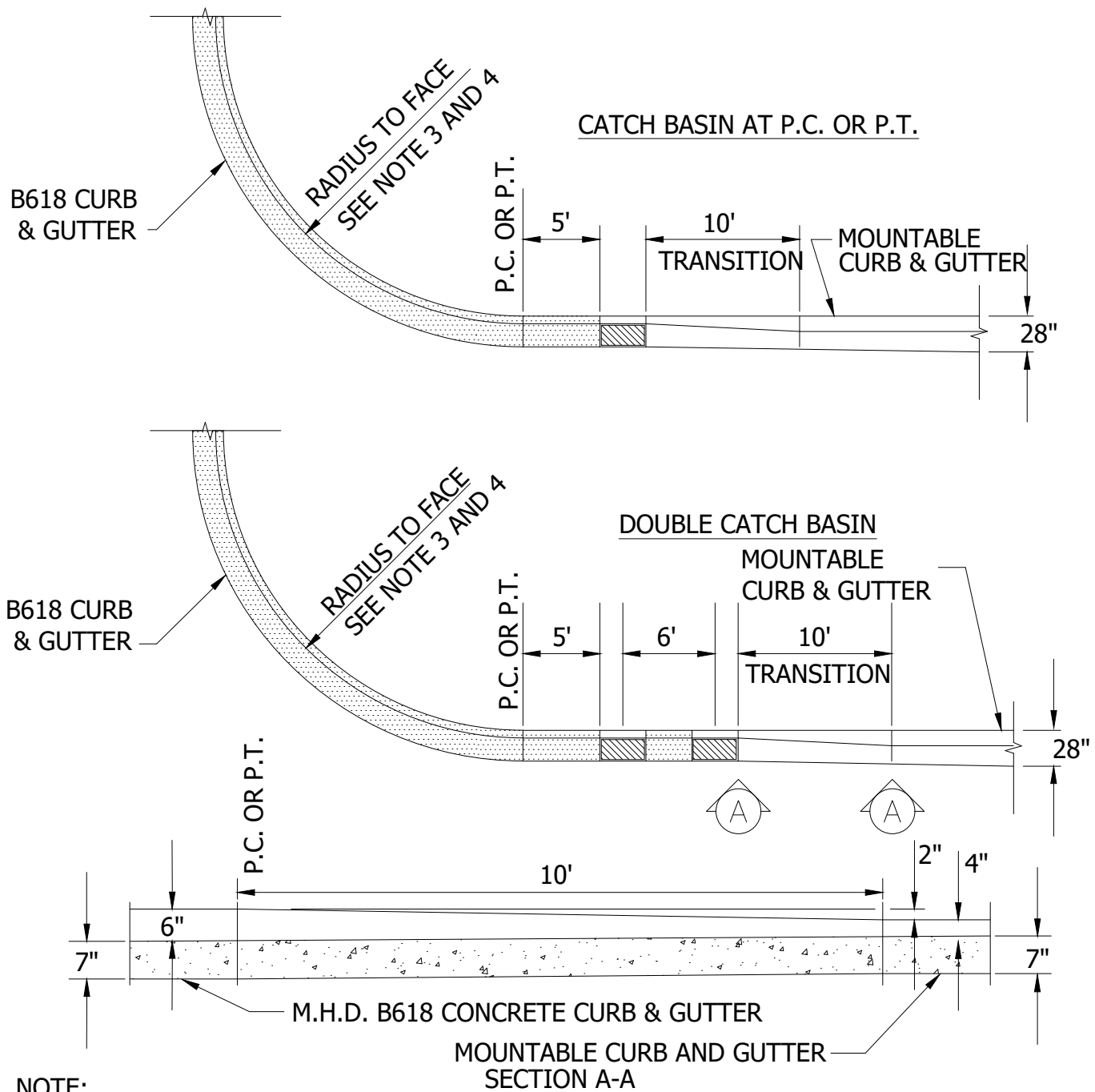

NOTE:

1. ALL RADII ARE MEASURED TO FACE OF CURB.
2. NO CATCH BASINS WILL BE CONSTRUCTED IN THE INTERSECTION RADII.
3. 30' RADII WILL BE REQUIRED AT INTERSECTIONS OF ALL COLLECTOR TO RESIDENTIAL STREETS.
4. 20' RADII WILL BE REQUIRED AT INTERSECTIONS OF ALL RESIDENTIAL TO RESIDENTIAL STREETS.

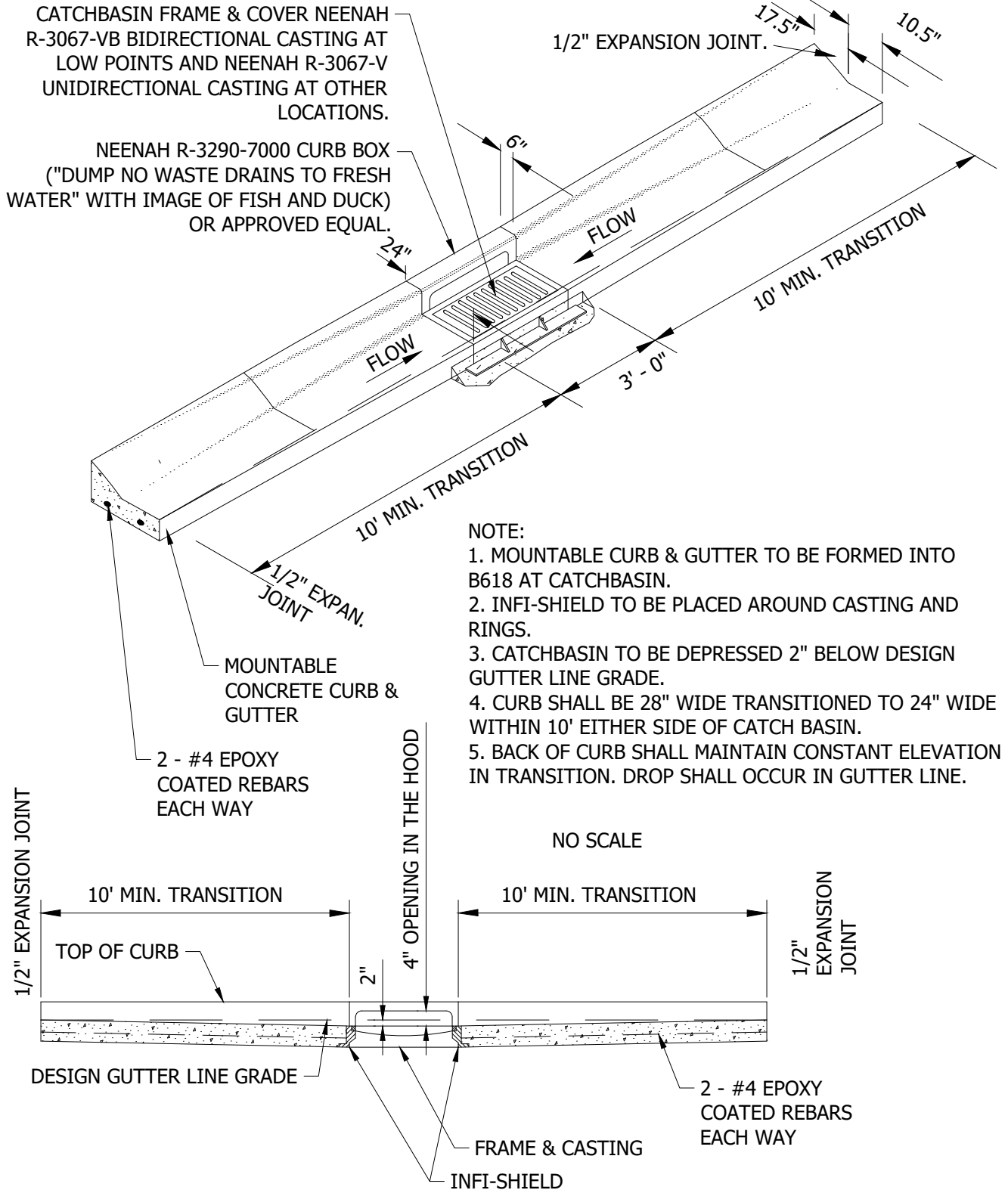

CATCHBASIN FRAME & COVER NEENAH R-3067-VB BIDIRECTIONAL CASTING AT LOW POINTS AND NEENAH R-3067-V UNIDIRECTIONAL CASTING AT OTHER LOCATIONS.

NEENAH R-3290-7000 CURB BOX ("DUMP NO WASTE DRAINS TO FRESH WATER" WITH IMAGE OF FISH AND DUCK) OR APPROVED EQUAL.

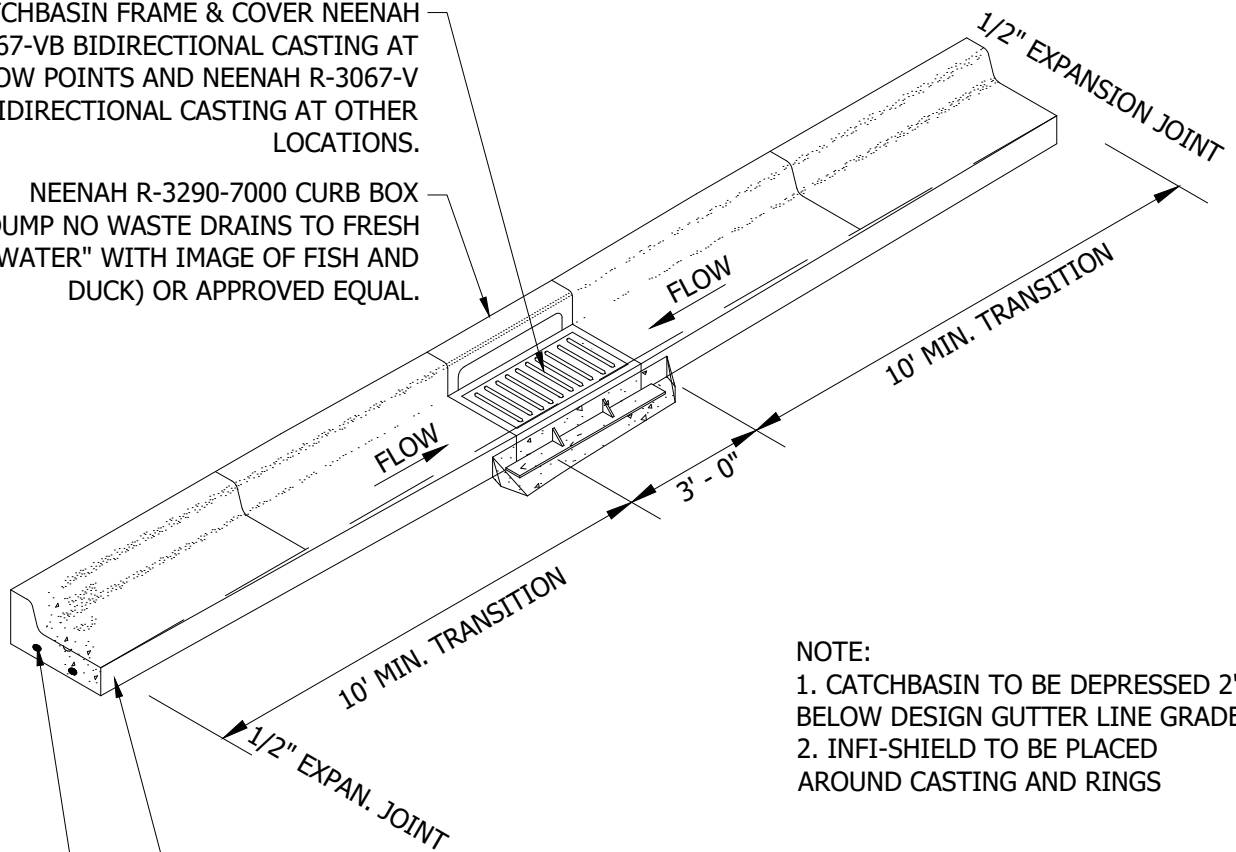

NOTE:

1. CATCHBASIN TO BE DEPRESSED 2" BELOW DESIGN GUTTER LINE GRADE.
2. INFI-SHIELD TO BE PLACED AROUND CASTING AND RINGS

B618 CONCRETE CURB & GUTTER

2 - #4 EPOXY COATED REBARS EACH WAY

NO SCALE

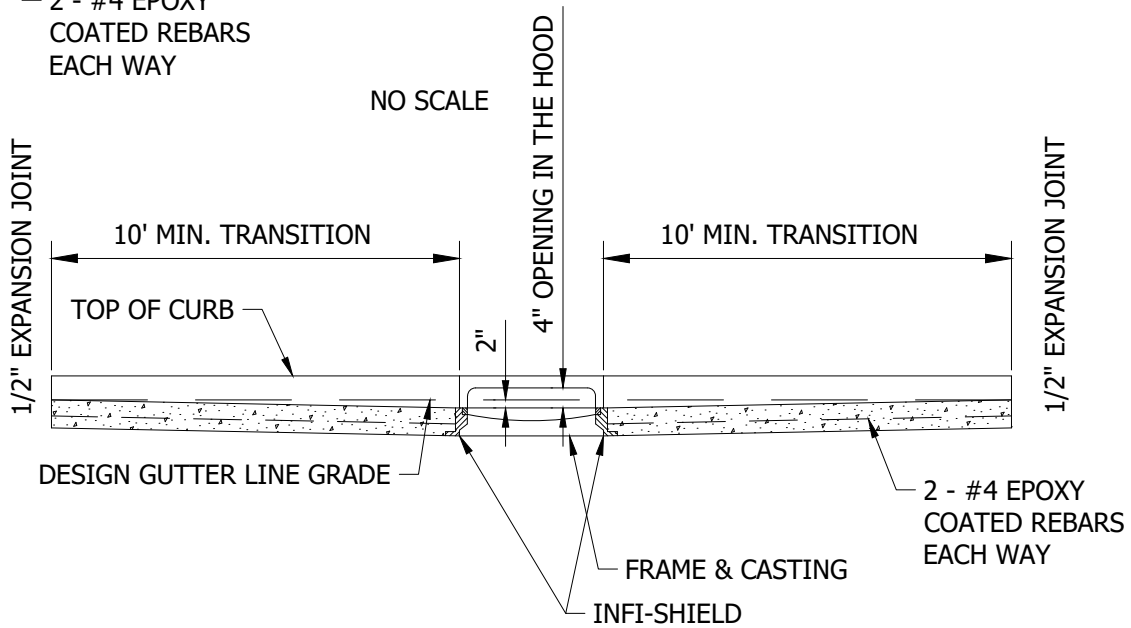

2026 DETAIL PLATES
REV.1

B618 CURB AND GUTTER CONSTRUCTION AT CATCH BASIN

LAST REVISION:
DEC 2025

PLATE NO.
STR-04

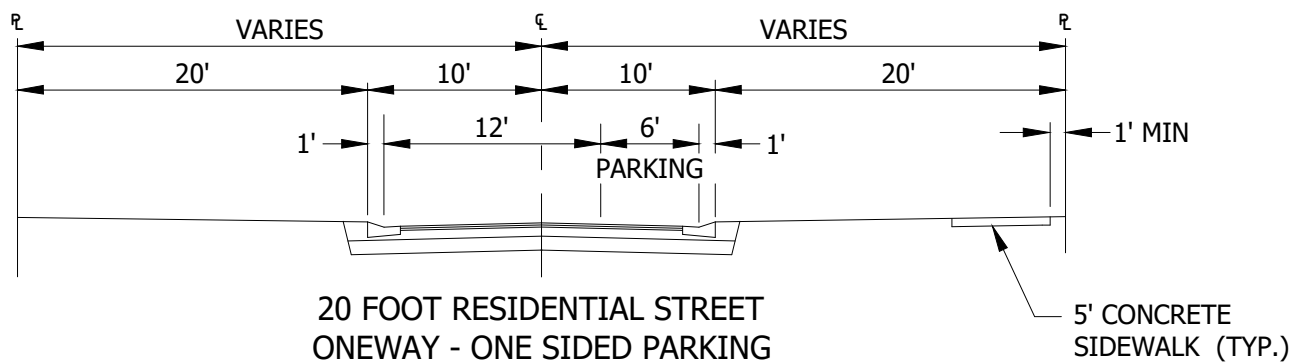
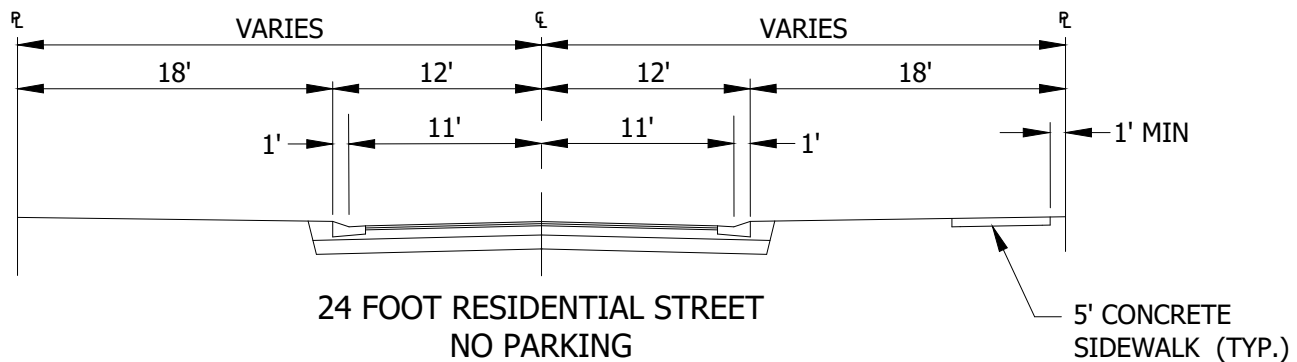
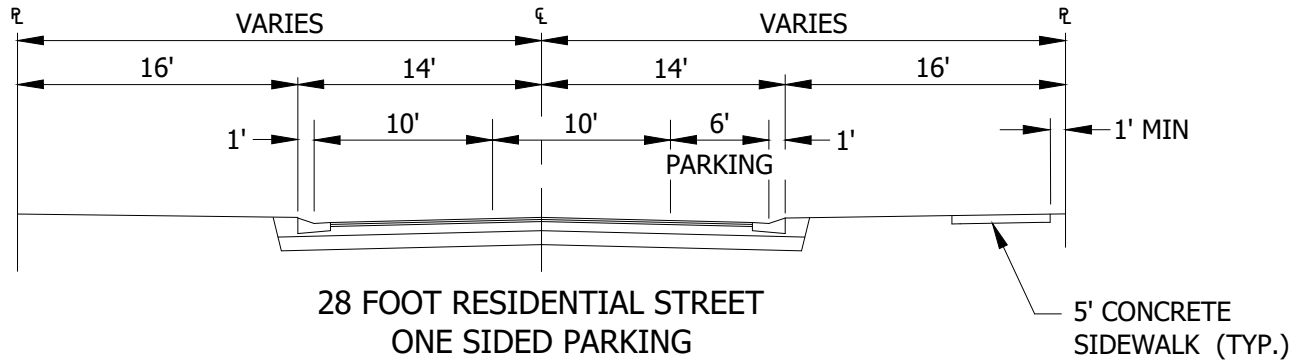
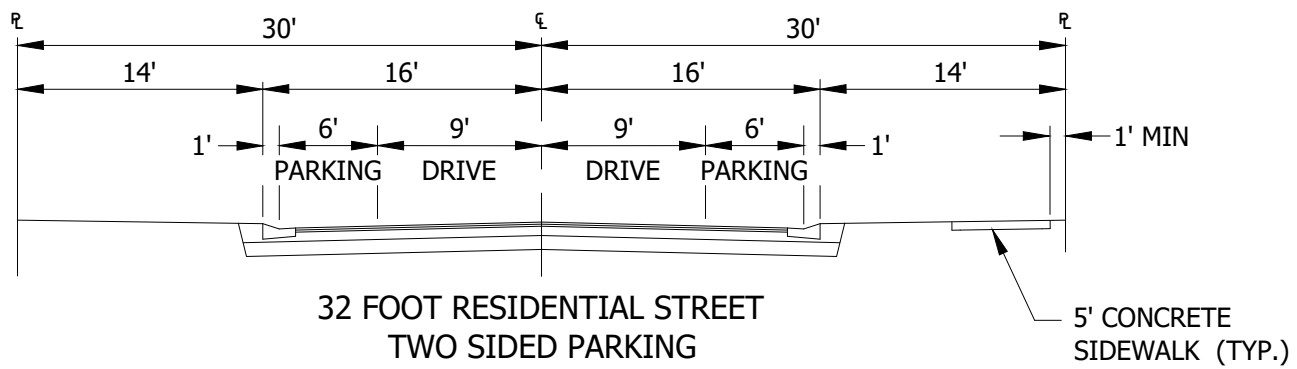

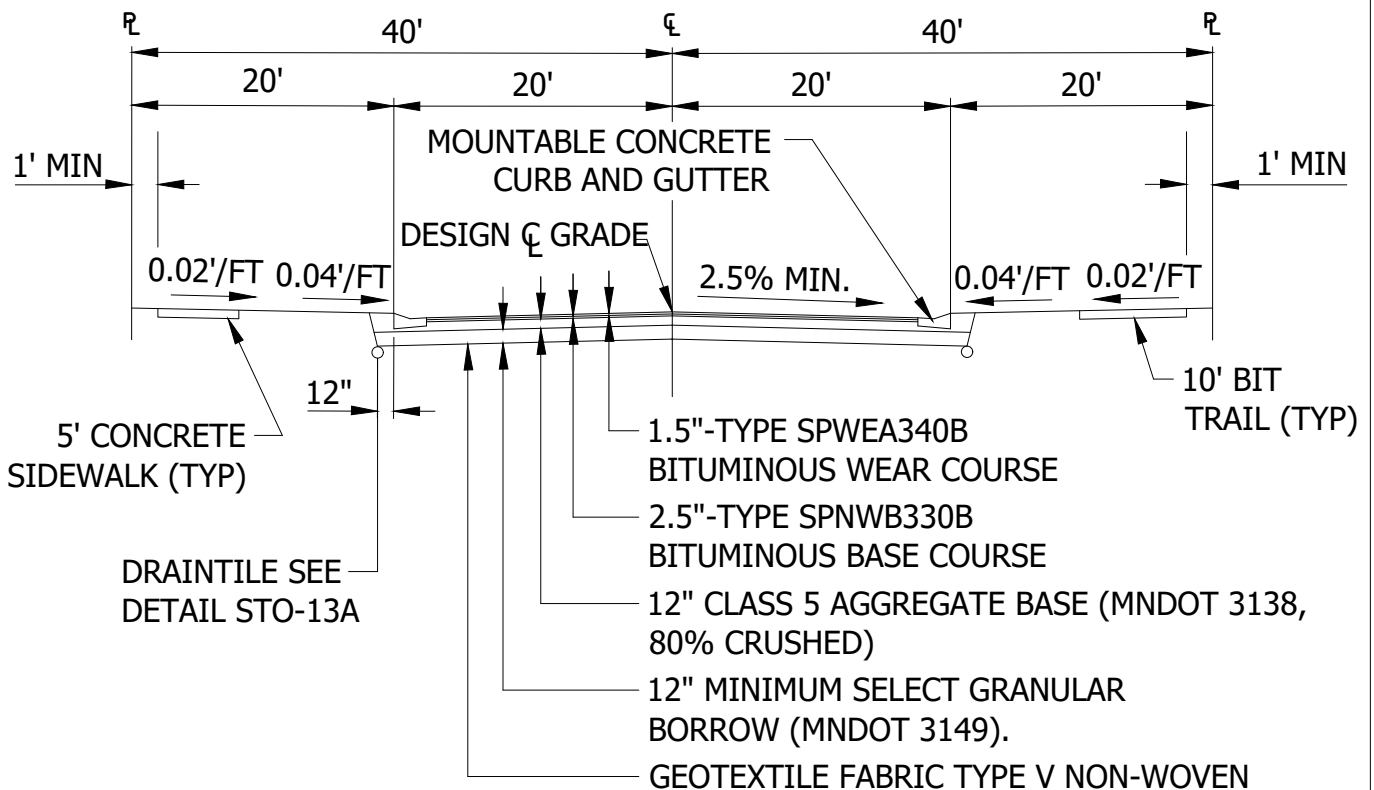

NOTE:

1. TYPICAL SECTION SHOWN IS THE MINIMUM COLLECTOR STREET REQUIREMENT. SEE SPECIFICATIONS FOR PROJECT SPECIFIC DETAILS.
2. SCH 40 DRAINTILE SHALL BE INSTALLED BEHIND CURB. DRAINTILE TO BE INSTALLED AS REQUIRED TO ADEQUATELY DRAIN ALL SELECT GRANULAR FILL AREAS.
3. STREET SHALL BE DESIGNED FOR A 40 MPH DESIGN SPEED WITH MINIMUM 0.60% AND MAXIMUM 6.00% GRADE.
4. THE CITY RESERVES THE RIGHT TO INCREASE THE STREET SECTION AND ADD DRAINTILE BASED ON SOIL CONDITIONS.
6. WEARING COURSES MAY HAVE A MAXIMUM OF 10% RECYCLED ASPHALT PAVEMENT (RAP). NO RECYCLED ASPHALT SHINGLES (RAS) ALLOWED IN WEARING COURSES.
7. NON-WEARING COURSES MAY HAVE A MAXIMUM OF 20% RECYCLED ASPHALT PAVEMENT (RAP).

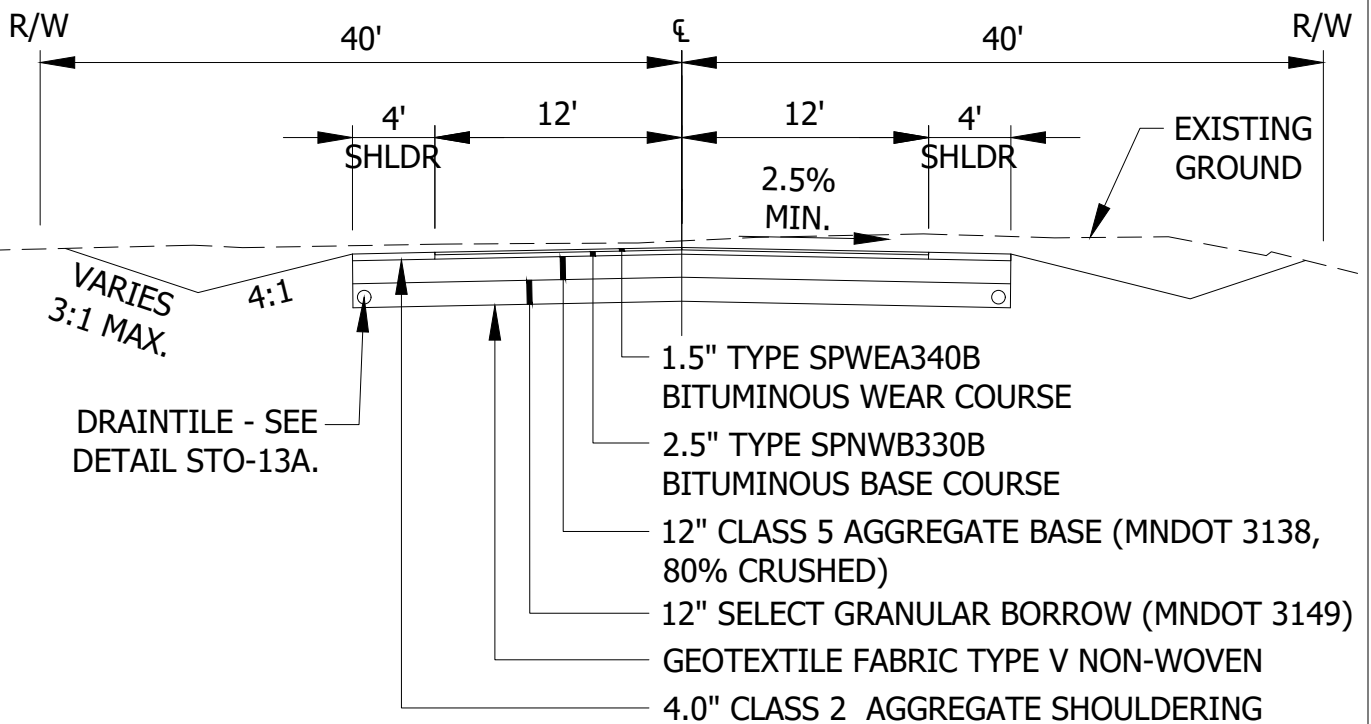

TYPICAL SECTION

NOTE:

1. TYPICAL SECTION SHOWN IS THE MINIMUM COLLECTOR STREET REQUIREMENT. SEE SPECIFICATIONS FOR PROJECT SPECIFIC DETAILS.
2. SCH 40 DRAINTILE TO BE INSTALLED AS REQUIRED TO ADEQUATELY DRAIN ALL SELECT GRANULAR FILL AREAS.
3. STREET SHALL BE DESIGNED FOR A 40 MPH DESIGN SPEED WITH MINIMUM 0.60% AND MAXIMUM 6.00% GRADE.
4. THE CITY RESERVES THE RIGHT TO INCREASE THE STREET SECTION AND ADD DRAINTILE BASED ON SOIL CONDITIONS.
6. WEARING COURSES MAY HAVE A MAXIMUM OF 10% RECYCLED ASPHALT PAVEMENT (RAP). NO RECYCLED ASPHALT SHINGLES (RAS) ALLOWED IN WEARING COURSES.
7. NON-WEARING COURSES MAY HAVE A MAXIMUM OF 20% RECYCLED ASPHALT PAVEMENT (RAP).

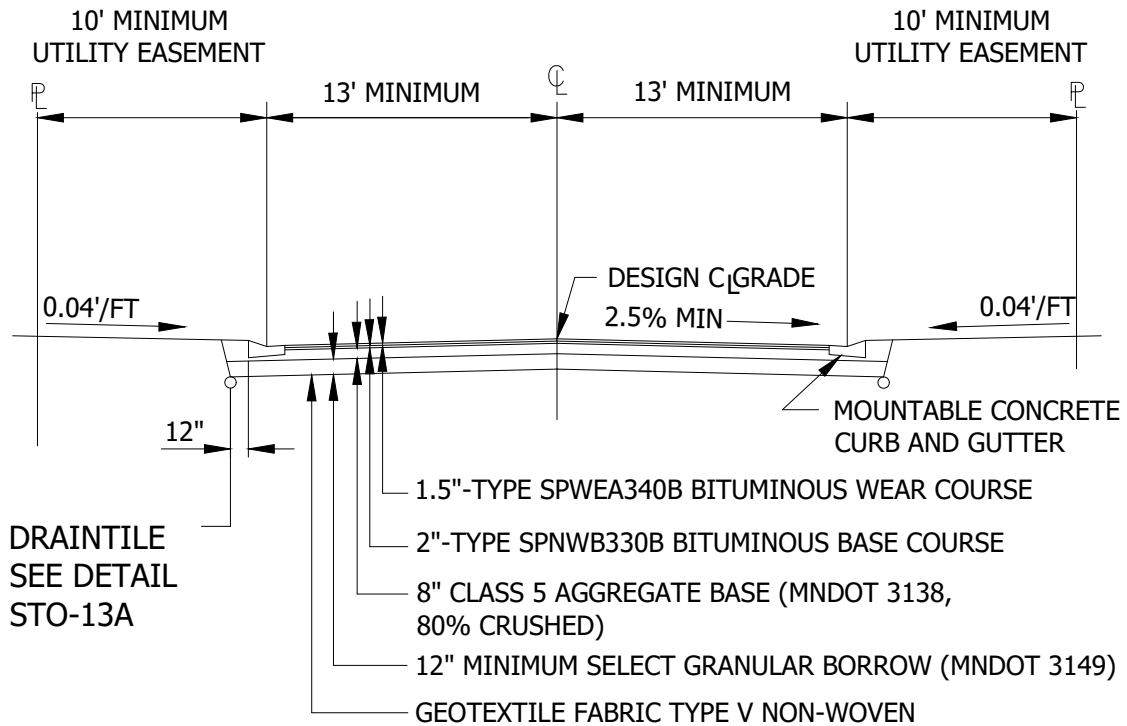

NOTE:

1. TYPICAL SECTION SHOWN IS THE MINIMUM RESIDENTIAL STREET REQUIREMENT. SEE SPECIFICATIONS FOR PROJECT SPECIFIC DETAILS.
2. SCH 40 DRAINTILE SHALL BE INSTALLED BEHIND CURB. DRAINTILE TO BE INSTALLED AS REQUIRED TO ADEQUATELY DRAIN ALL SELECT GRANULAR FILL AREAS.
3. STREET SHALL BE DESIGNED FOR A 30 MPH DESIGN SPEED WITH MINIMUM 0.60% AND MAXIMUM OF 6.00% GRADE.
4. THE CITY RESERVES THE RIGHT TO INCREASE THE STREET SECTION AND ADD DRAINTILE BASED ON SOIL CONDITIONS.
5. CITY ENGINEER TO DETERMINE WIDTHS.
6. WEARING COURSES MAY HAVE A MAXIMUM OF 10% RECYCLED ASPHALT PAVEMENT (RAP). NO RECYCLED ASPHALT SHINGLES (RAS) ALLOWED IN WEARING COURSES.
7. NON-WEARING COURSES MAY HAVE A MAXIMUM OF 20% RECYCLED ASPHALT PAVEMENT (RAP).



2026 DETAIL PLATES
REV.1

**TYPICAL PRIVATE STREET SECTION,
NO PARKING**

LAST REVISION:
DEC 2024

PLATE NO.
STR-07

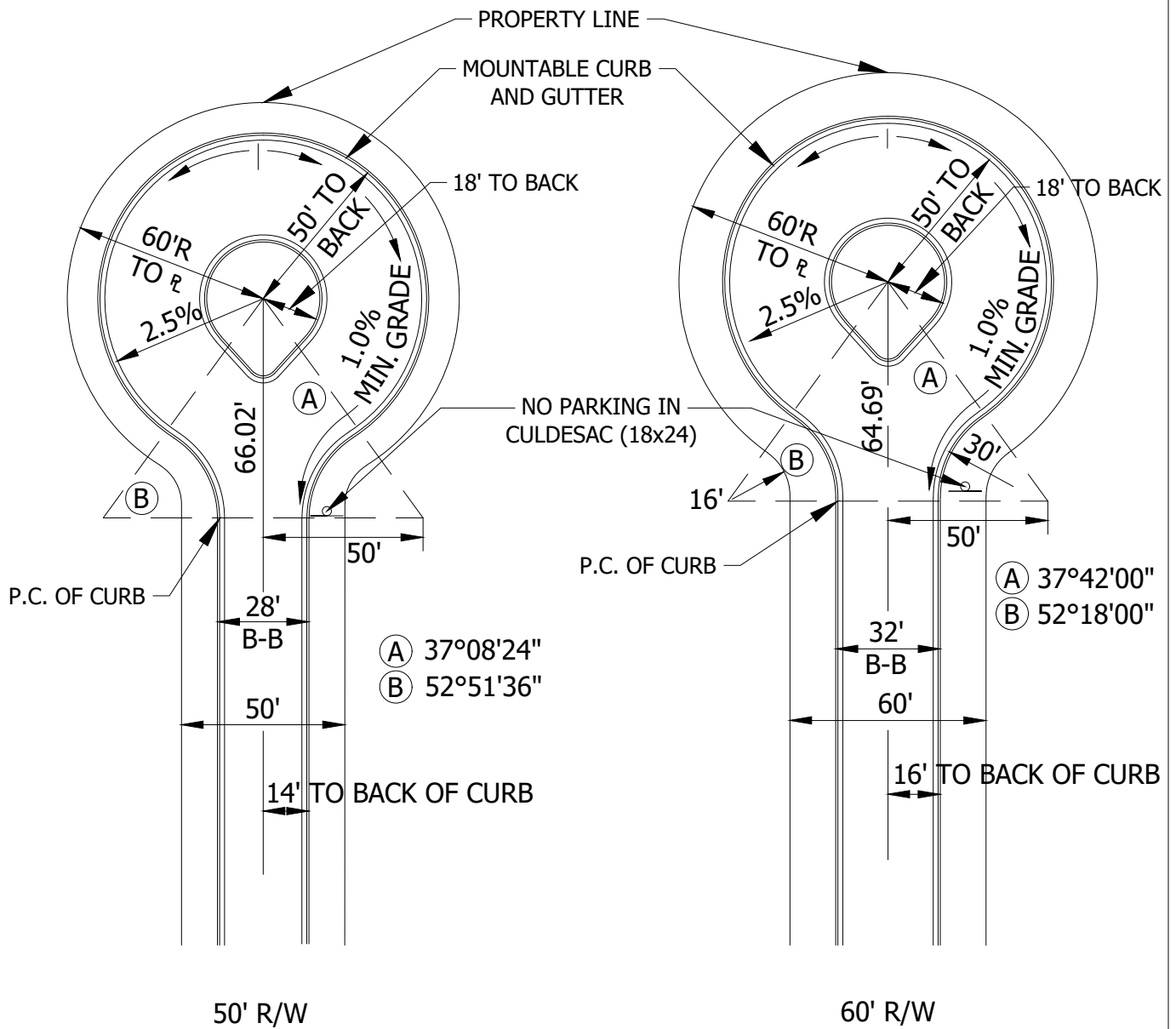

NOTE:

1. ALL RADIUS MEASUREMENTS TAKEN FROM THE FACE OF CURB UNLESS OTHERWISE STATED.
2. ALL CENTER ISLAND SURFACES MUST BE APPROVED BY THE CITY AND PRIVATELY MAINTAINED.
3. SEE STR-27 FOR ADDITIONAL ISLAND REQUIREMENTS.
4. ON STREETS LONGER THAN 500' ENDING IN A CULDESAC, A "NO OUTLET" (W14-2) SIGN IS REQUIRED AT THE START OF THE STREET.



2026 DETAIL PLATES
REV.1

**TYPE I CUL-DE-SAC WITH ISLAND
FOR A 50' R/W AND A 60' R/W**

LAST REVISION:
DEC 2025

PLATE NO.
STR-08

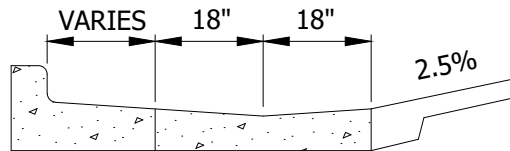
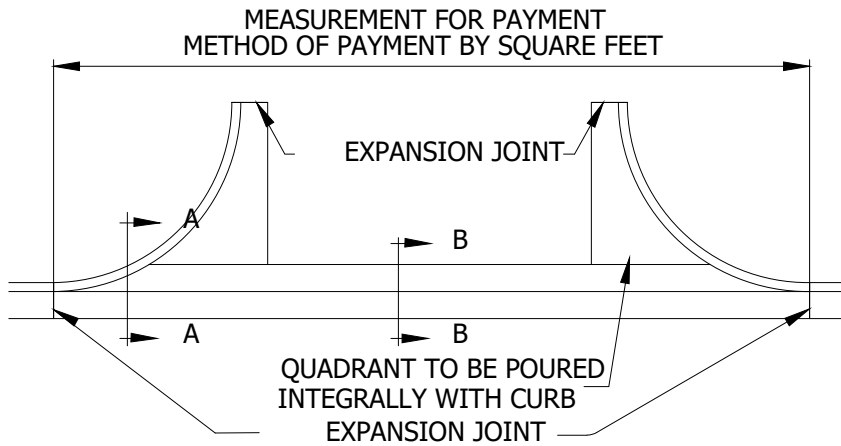

THIS DETAIL IS THE
SAME FOR BOTH SIDES
OF THE VALLEY GUTTER

SECTION A-A
THRU B618 C & G

BITUMINOUS SECTION

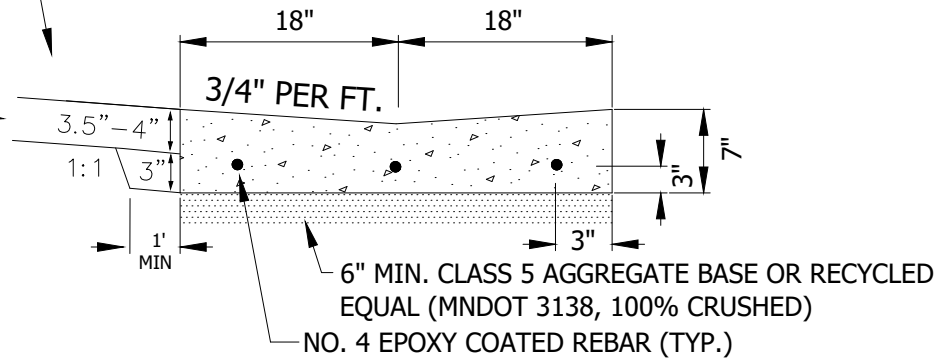

SECTION B-B THRU
CONCRETE GUTTER

SECTION
NO SCALE

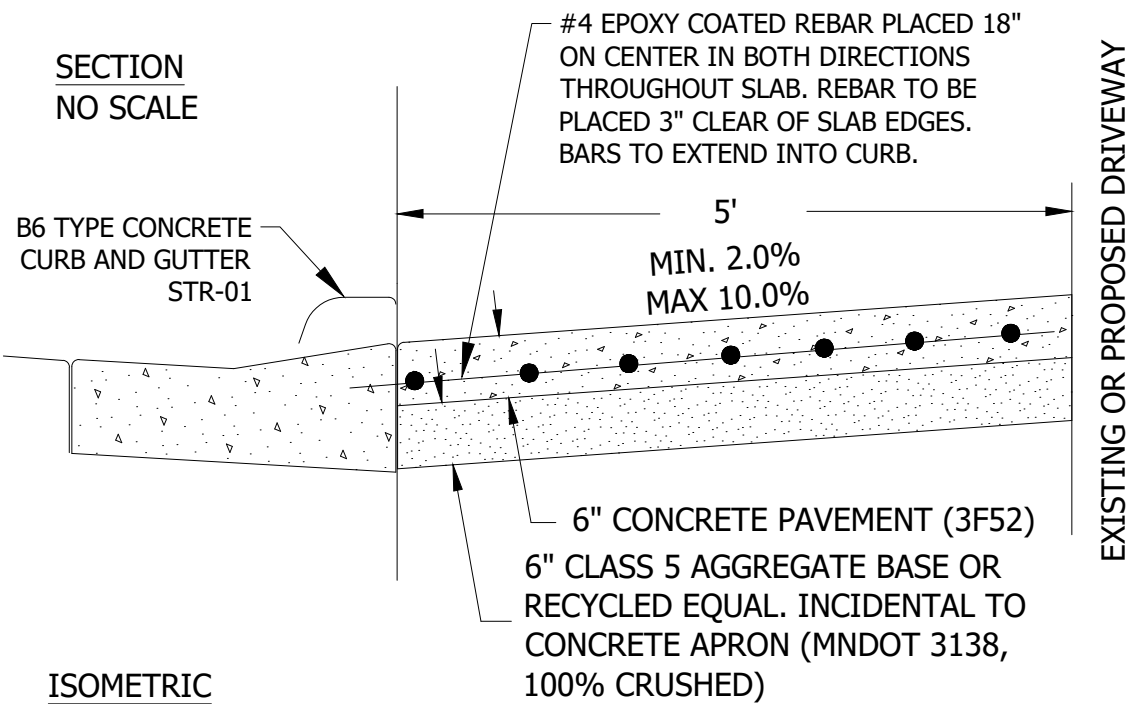

ISOMETRIC
NO SCALE

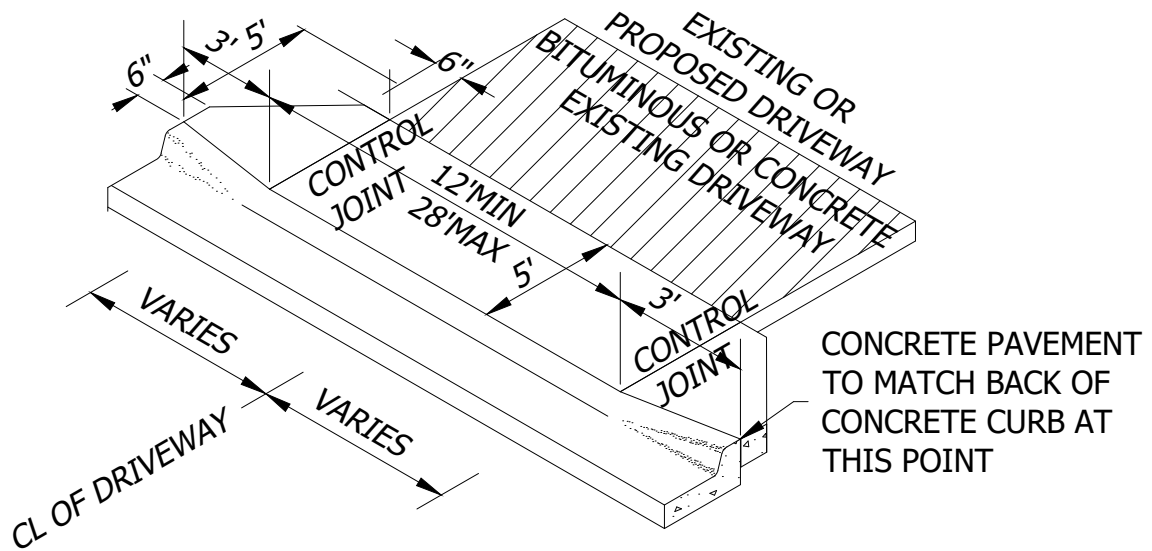

NOTE:

1. CONTROL JOINTS IN CONCRETE CURB NOT TO EXCEED 10' SPACING THROUGH DRIVEWAY SECTION.
2. DRIVEWAY WINGS ARE REQUIRED WITH THE B6 STYLE CURBING. THE MAXIMUM DRIVEWAY WIDTH AT THE CURB IS 28' PLUS THE WIDTH OF THE WINGS. MAXIMUM WIDTH OF DRIVEWAY AT THE PROPERTY LINE IS ALSO 28'.
3. ADD EXPANSION JOINTS WHEN TYING INTO EXISTING CONCRETE.

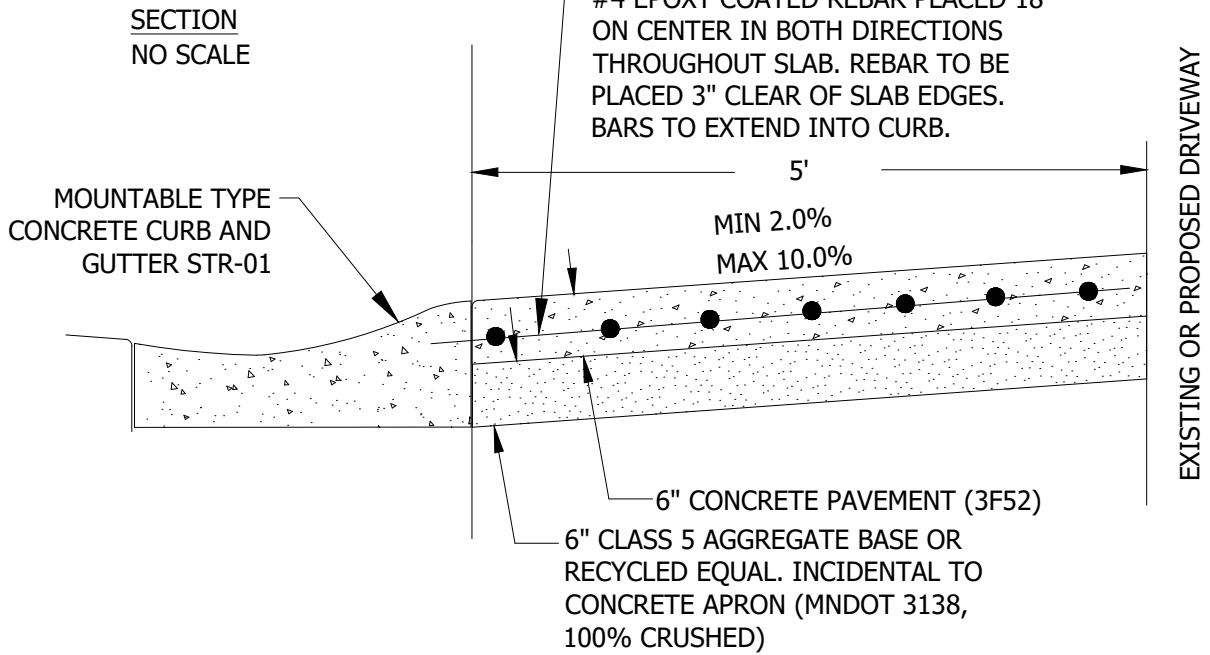

ISOMETRIC
NO SCALE

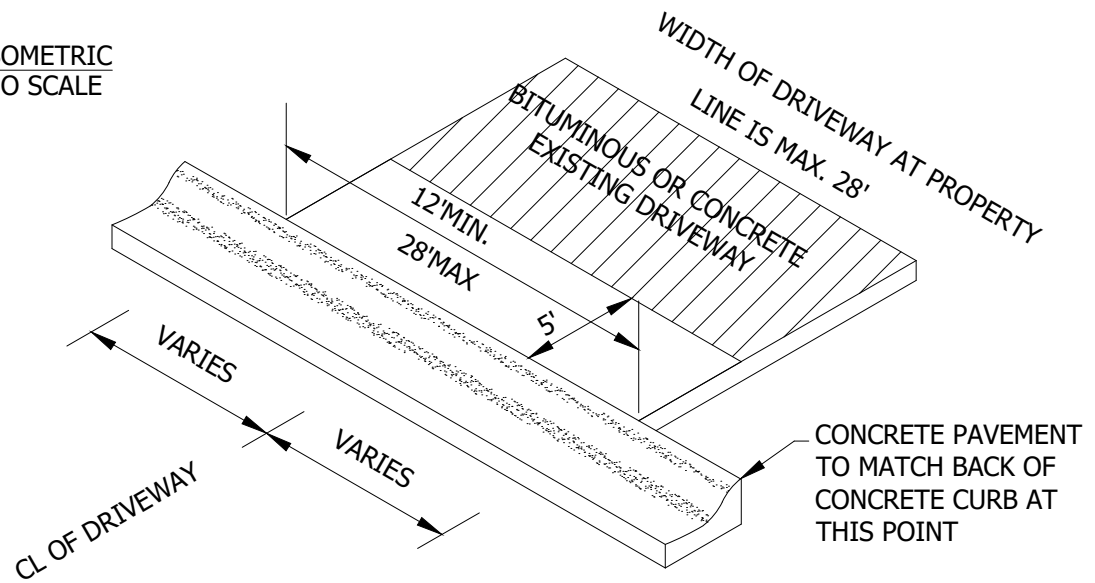

NOTE:

1. CONTROL JOINTS IN CONCRETE CURB NOT TO EXCEED 10' SPACING THROUGH DRIVEWAY SECTION.
2. DRIVEWAY WINGS ARE NOT REQUIRED WITH THE MOUNTABLE STYLE CURBING. THE MAXIMUM DRIVEWAY WIDTH AT THE CURB IS 28'. MAXIMUM WIDTH OF DRIVEWAY AT THE PROPERTY LINE IS ALSO 28'.
3. ADD EXPANSION JOINTS WHEN TYING INTO EXISTING CONCRETE.

SECTION
NO SCALE

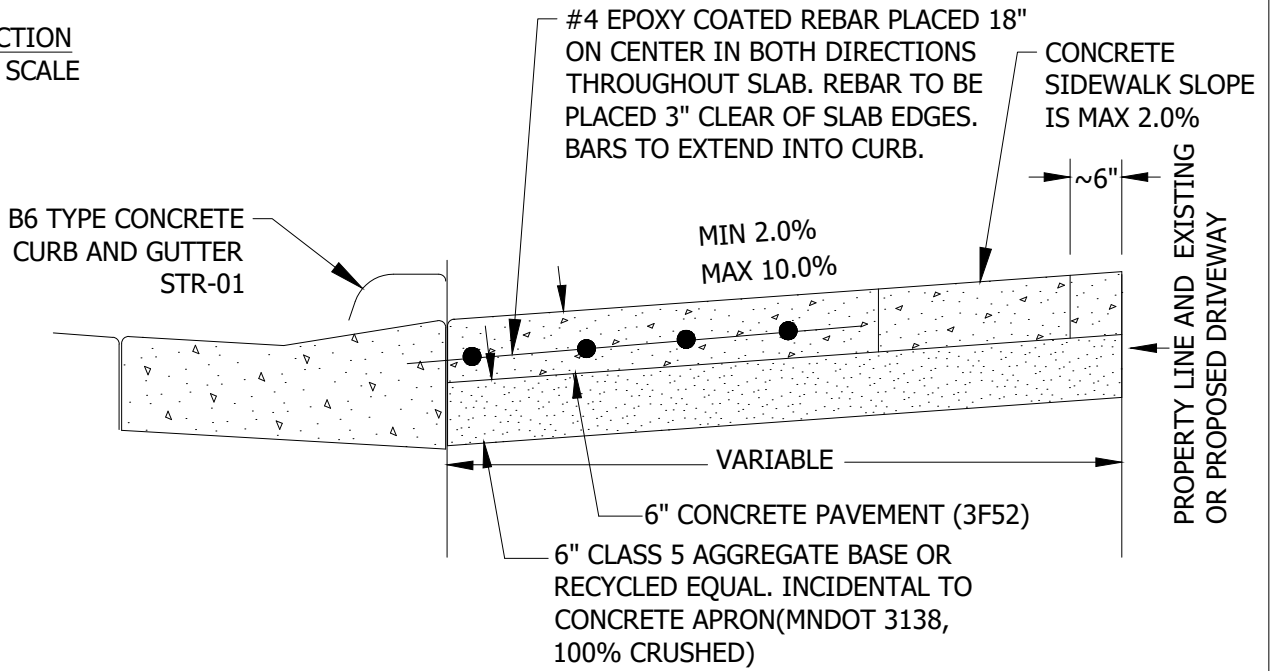

ISOMETRIC
NO SCALE

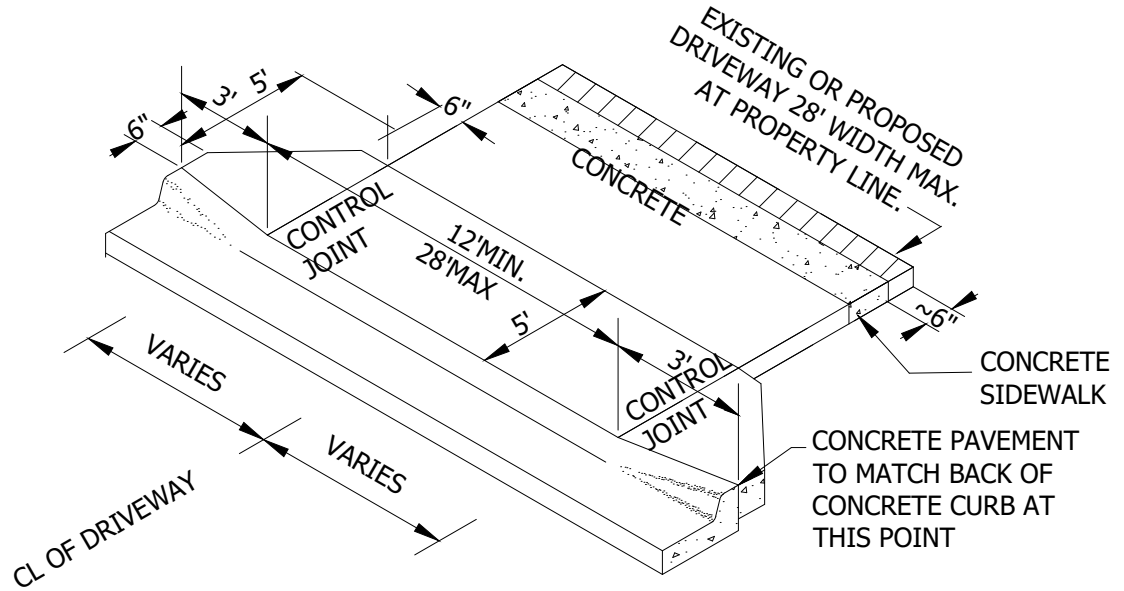

NOTE:

1. CONTROL JOINTS IN CONCRETE CURB NOT TO EXCEED 10' SPACING THROUGH DRIVEWAY SECTION.
2. CONCRETE MUST BE CONSTRUCTED BETWEEN SIDEWALK AND DRIVEWAY APRON.
3. CONCRETE SIDEWALK THROUGH DRIVEWAY IS 6" THICK.
4. DRIVEWAY WINGS ARE REQUIRED WITH THE B6 STYLE CURBING. THE MAXIMUM DRIVEWAY WIDTH AT THE CURB IS 28' PLUS THE WIDTH OF THE WINGS. MAXIMUM WIDTH OF DRIVEWAY AT THE PROPERTY LINE IS ALSO 28'.
5. ADD EXPANSION JOINTS WHEN TYING INTO EXISTING CONCRETE.
6. DOWEL REBAR INTO EXISTING SIDEWALK.

SECTION
NO SCALE

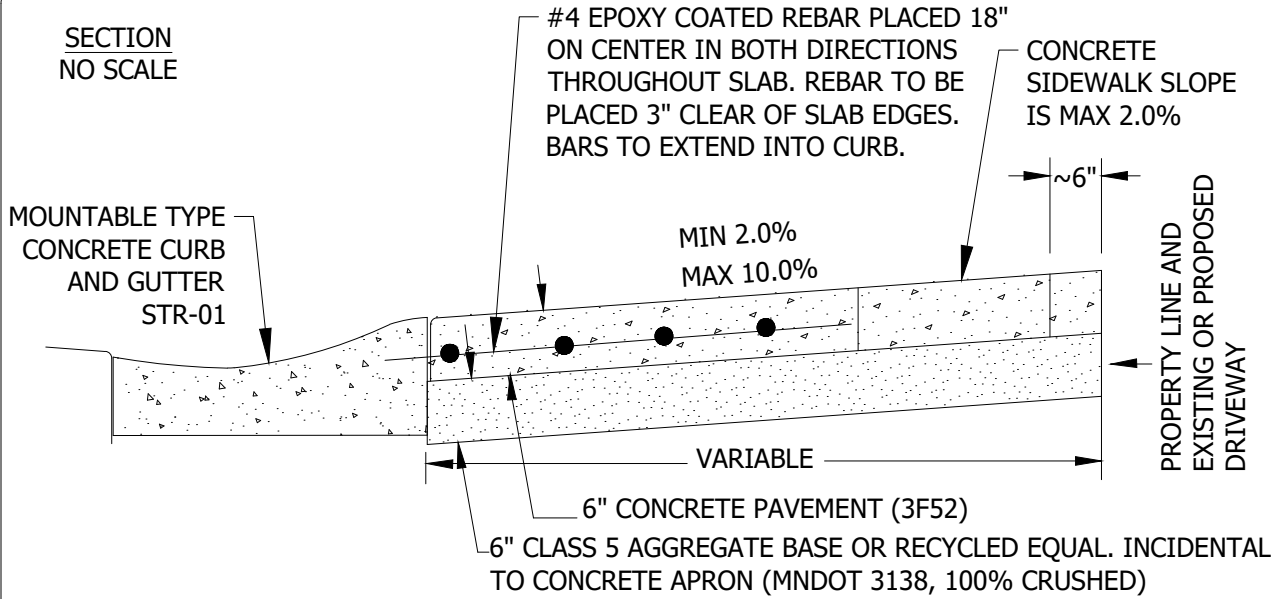

ISOMETRIC
NO SCALE

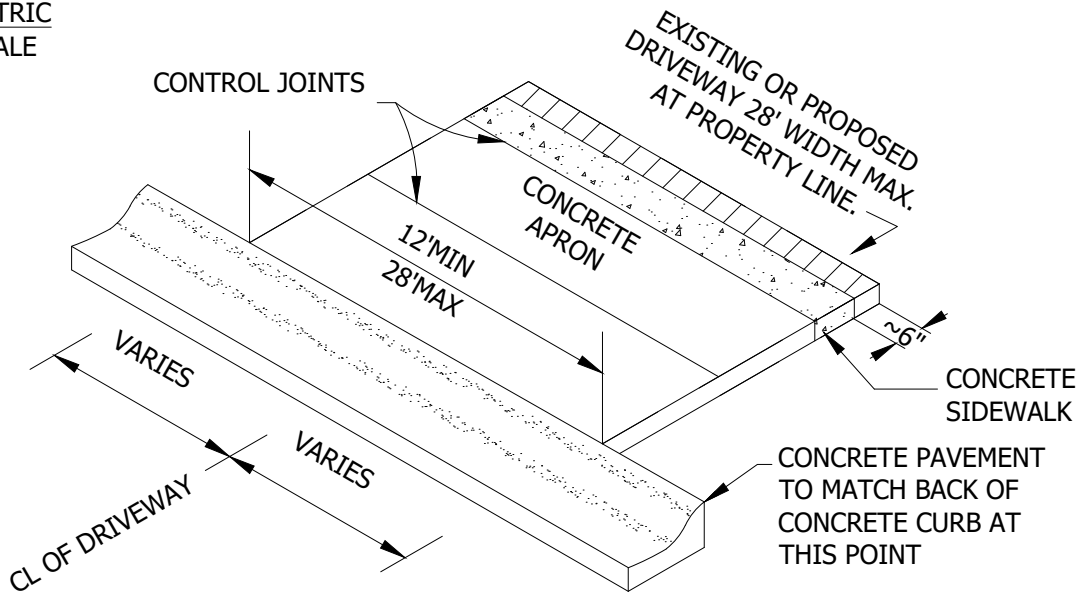

NOTE:

1. CONTROL JOINTS IN CONCRETE CURB NOT TO EXCEED 10' SPACING THROUGH DRIVEWAY SECTION.
2. CONCRETE MUST BE CONSTRUCTED BETWEEN SIDEWALK AND DRIVEWAY APRON.
3. CONCRETE SIDEWALK THROUGH DRIVEWAY IS 6" THICK.
4. DRIVEWAY WINGS ARE NOT REQUIRED WITH THE MOUNTABLE STYLE CURBING. THE MAXIMUM DRIVEWAY WIDTH AT THE CURB IS 28'. MAXIMUM WIDTH OF DRIVEWAY AT THE PROPERTY LINE IS ALSO 28'.
5. ADD EXPANSION JOINT WHEN TYING INTO EXISTING CONCRETE.
6. DOWEL REBAR INTO EXISTING SIDEWALK.

#4 EPOXY COATED REBAR PLACED 10" ON CENTER IN BOTH DIRECTIONS THROUGHOUT SLAB. REBAR TO BE PLACED 3" CLEAR OF SLAB EDGES.

SECTION A-A
NO SCALE

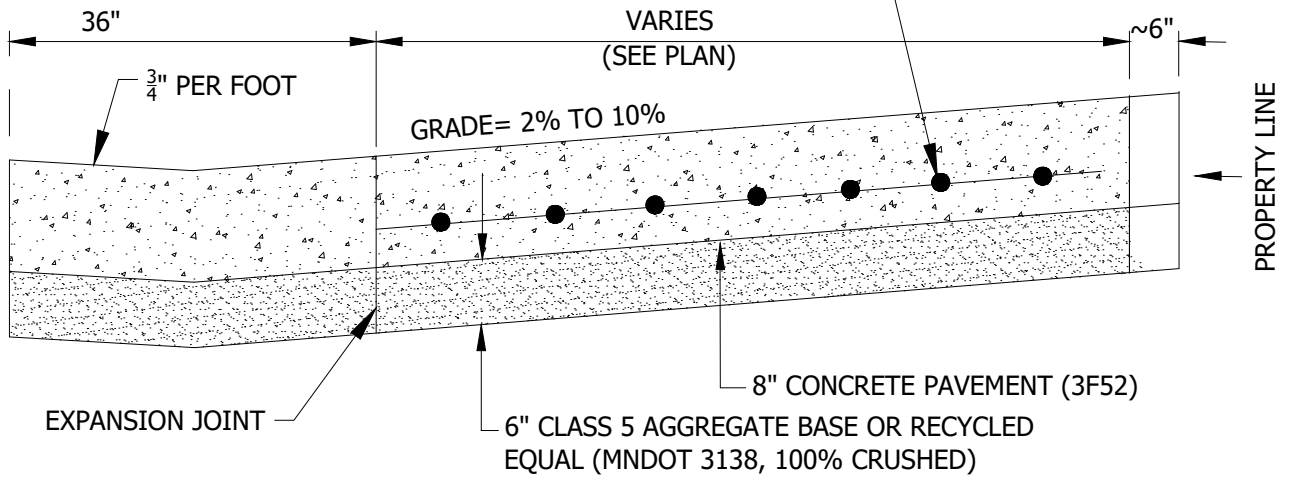

PLAN
NO SCALE

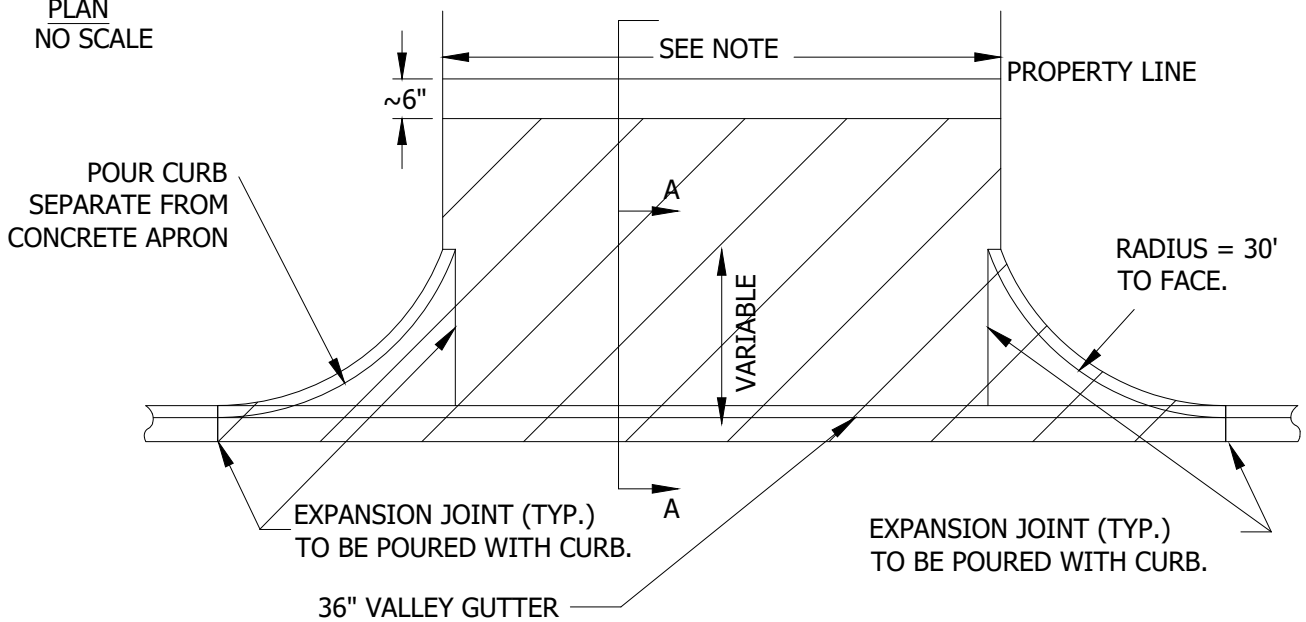

NOTES:

1. MAX COMMERCIAL DRIVEWAY WIDTH TO BE 32' AT RIGHT-OF-WAY.
2. APRON SHALL BE CONCRETE TO 1' PAST END OF CURB RADIUS OR 0.5' FROM PROPERTY LINE, WHICHEVER IS FURTHER FROM THE STREET.
3. ADD EXPANSION JOINTS WHEN TYING INTO EXISTING CONCRETE.

#4 EPOXY COATED REBAR PLACED 10" ON CENTER IN BOTH DIRECTIONS THROUGHOUT SLAB. REBAR TO BE PLACED 3" CLEAR OF SLAB EDGES.

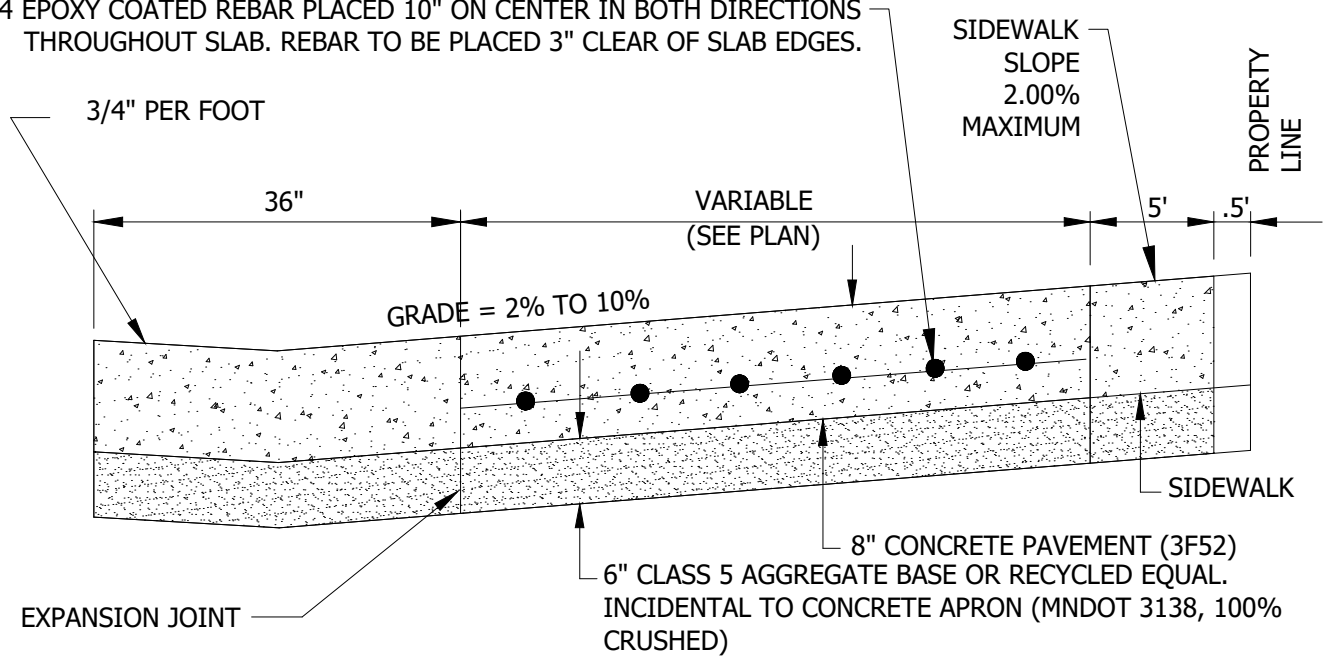

SECTION A-A
NO SCALE

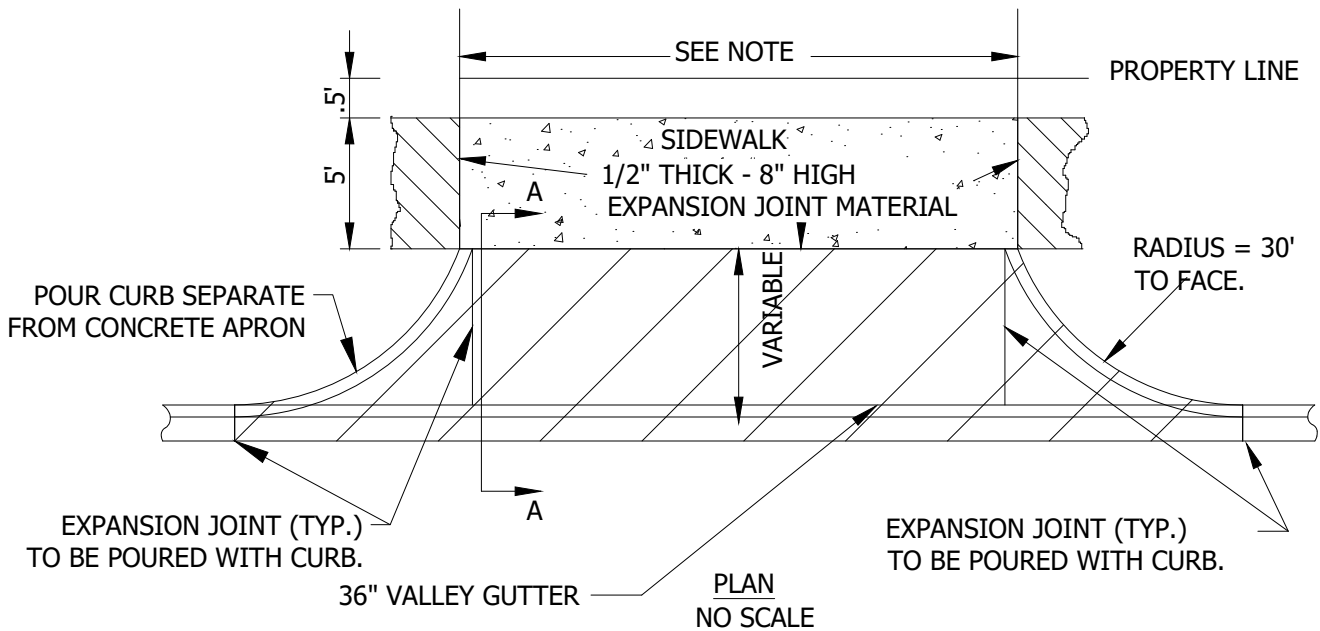

NOTE:

1. MAXIMUM COMMERCIAL DRIVEWAY WIDTH TO BE 32' AT END OF RIGHT-OF-WAY OR END OF RADIUS, WHICHEVER IS BIGGER.
2. ADD EXPANSION JOINS WHEN TYING INTO EXISTING CONCRETE.
3. DOWEL REBAR INTO EXISTING SIDEWALK.

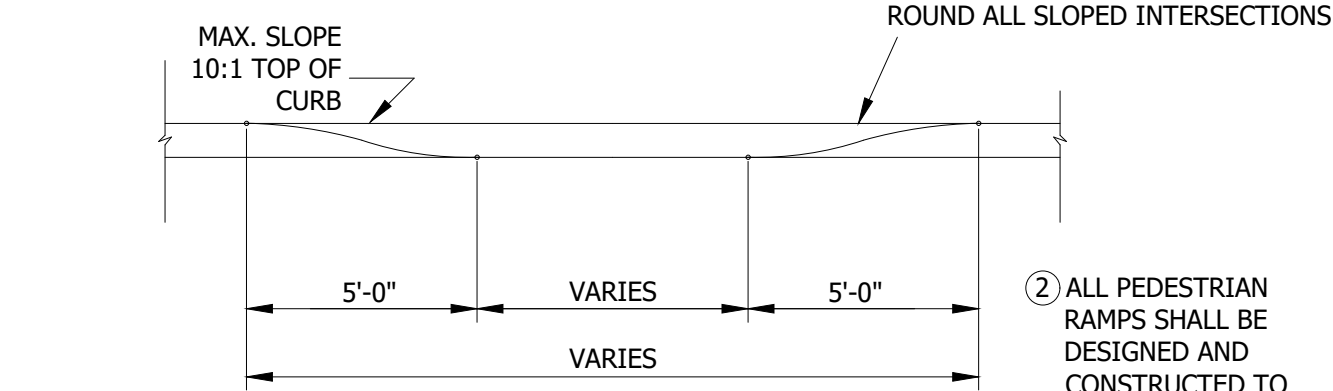
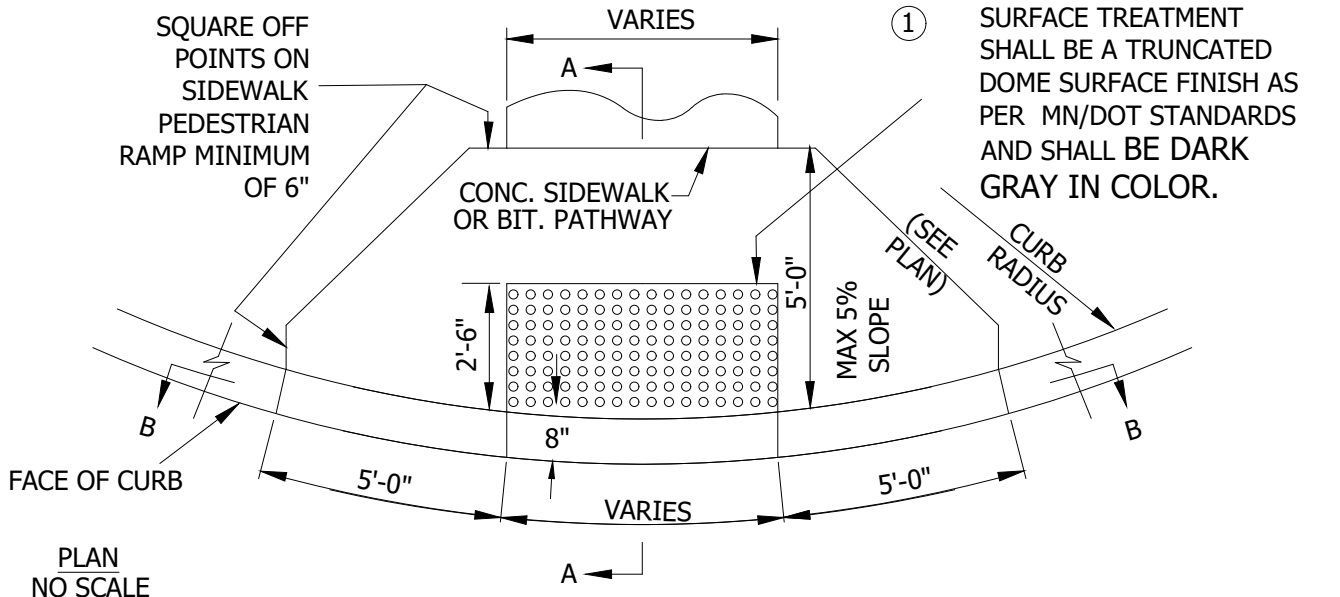

② ALL PEDESTRIAN RAMPS SHALL BE DESIGNED AND CONSTRUCTED TO MEET THE LATEST ADA REQUIREMENTS AND CONFORM TO THE LATEST MNDOT PED RAMP GUIDELINES

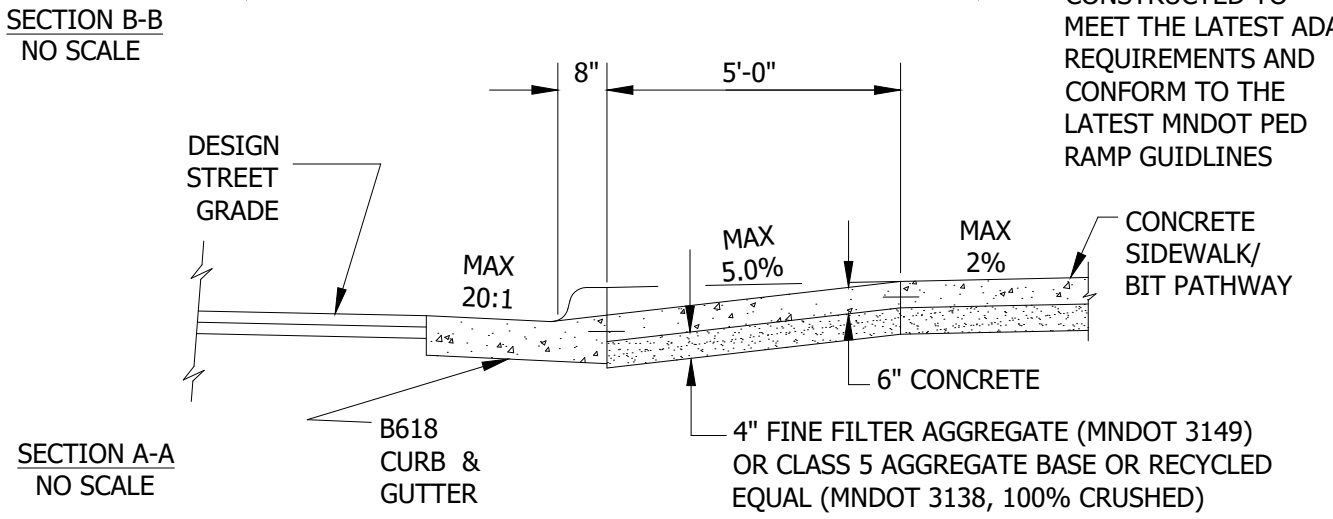

③ DRILL AND GROUT NO. 4 X 12" LONG (6" EMBEDDED) REINFORCEMENT BARS (EPOXY COATED) AT 36" MAX CENTER TO CENTER MIN 12" SPACING FROM CONSTRUCTION JOINTS (PER MNDOT PEDESTRIAN RAMP DETAIL).

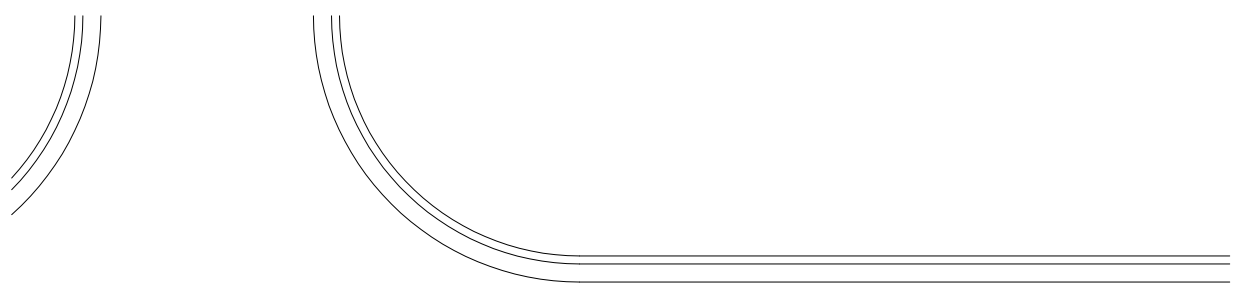

⊕ ROADWAY

SEE CURB RAMP DETAIL
PLATE (CITY PLATE STR-16)

CONCRETE CURB AND GUTTER

RADIUS
TO FACE

VARIES

CONCRETE OR BITUMINOUS (WIDTH VARIES)

R

1'

STOP SIGN

PLAN
NO SCALE

NOTE: DIMENSIONS DEPEND ON TYPE OF PATHWAY OR SIDEWALK.



2026 DETAIL PLATES
REV.1

SIDEWALK/BIKE PATH CURB RAMP
GENERAL LOCATION

LAST REVISION:
OCT 2024

PLATE NO.
STR-17

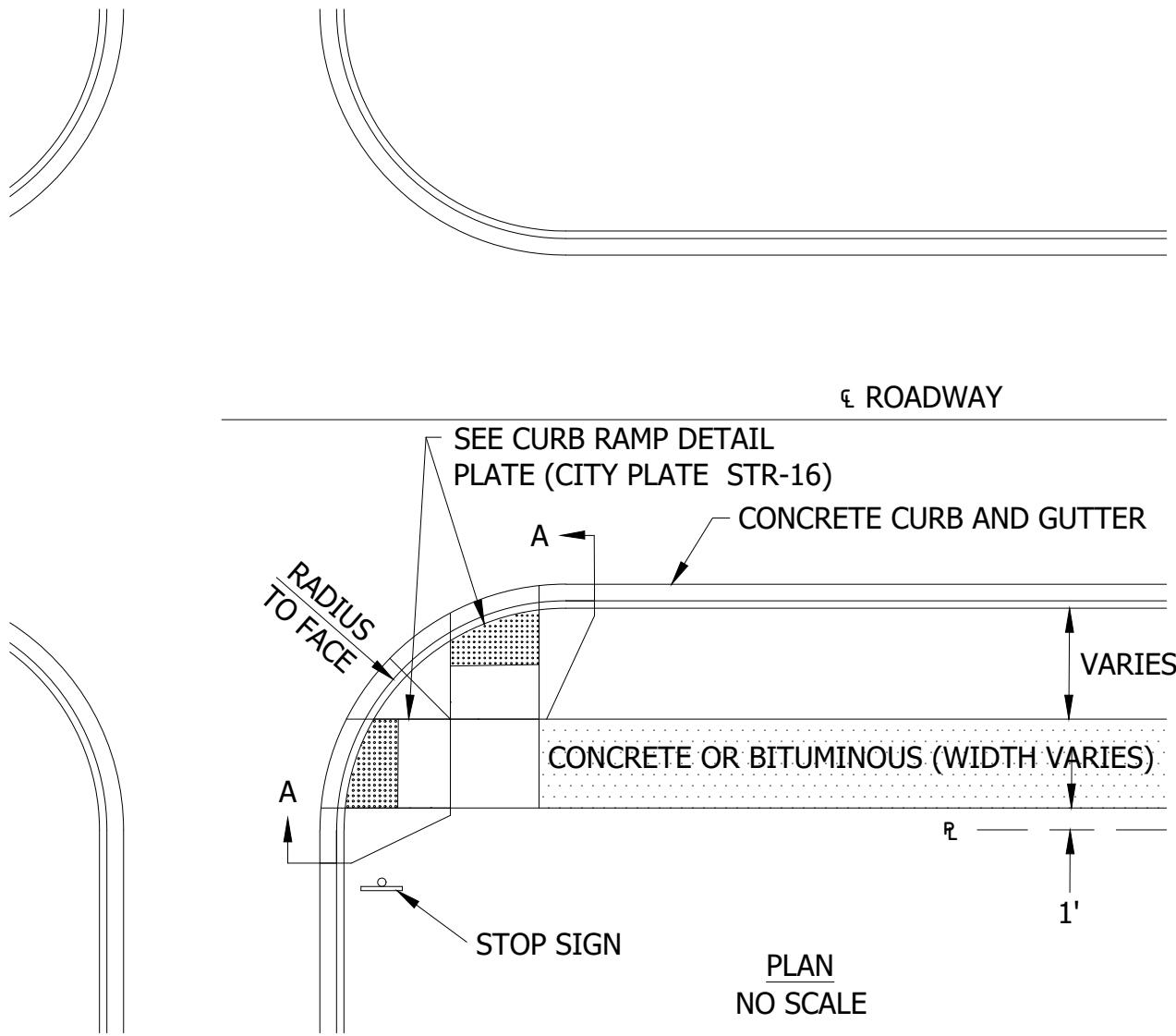

PLAN
NO SCALE

CITY ENGINEER MAY DETERMINE THAT RADIAL DOMES ARE NECESSARY IF TRANSITION DISTANCE BETWEEN TWO LANDING AREAS IS NOT SUFFICIENT OR IF DETERMINED NECESSARY BY ENGINEER.

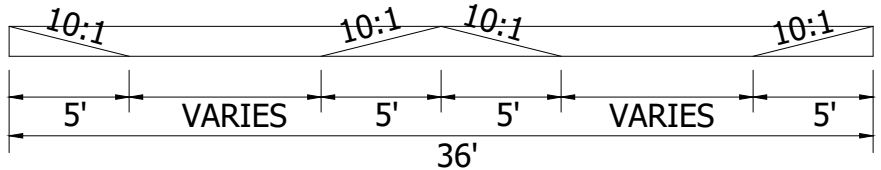

SECTION A-A
PROFILE
NO SCALE



DOUBLE SIDEWALK/BIKE PATH CURB RAMP
GENERAL LOCATION

LAST REVISION:
OCT 2024

PLATE NO.
STR-18

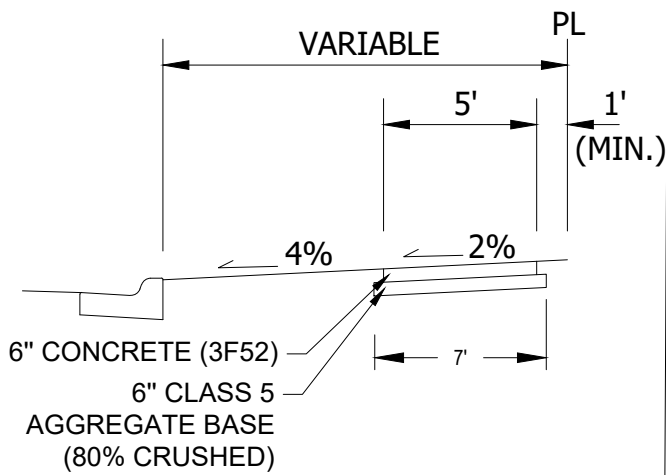

NEIGHBORHOOD SIDEWALK WITH BOULEVARD

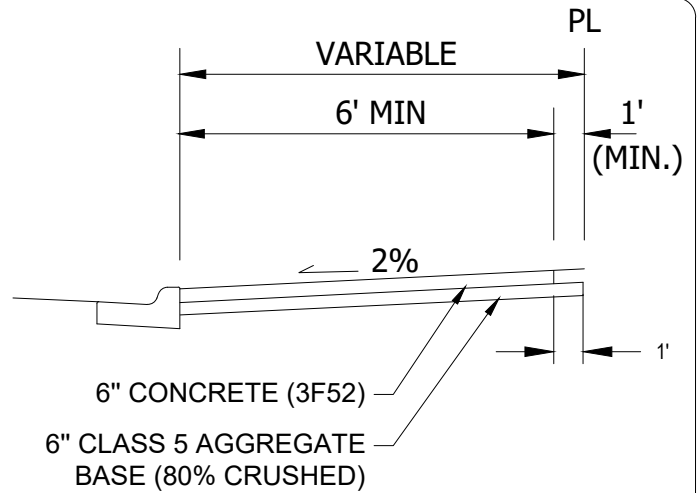

NEIGHBORHOOD SIDEWALK ADJACENT TO BACK OF CURB

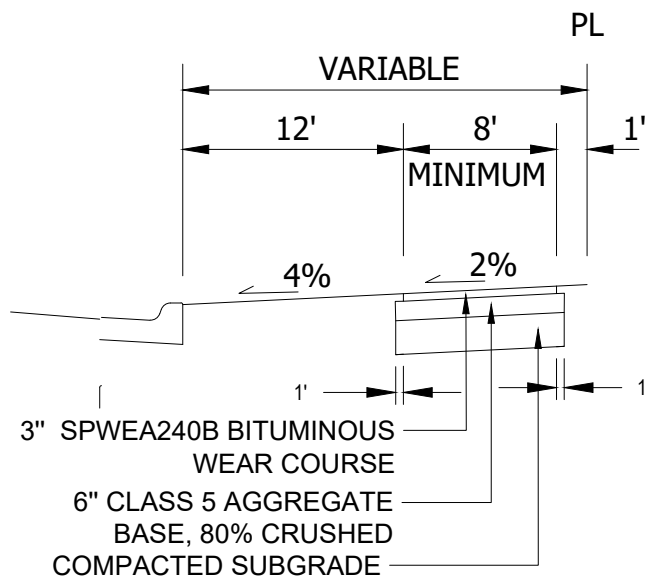

COMMUNITY ROADWAY TRAIL URBAN SECTION

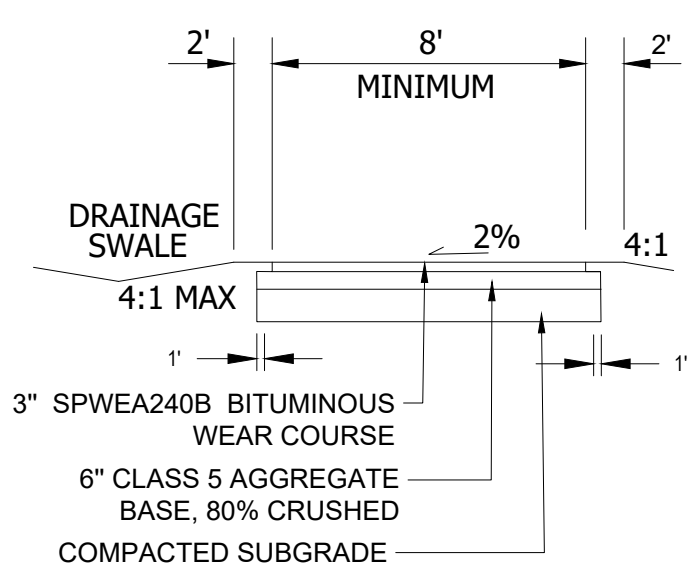

COMMUNITY GREENWAY TRAIL

1. RUNNING SLOPE OF TRAILS, SIDEWALKS, OR PATHS MUST COMPLY WITH CURRENT ADA GUIDELINES.
2. TRAIL WEARING COURSES MAY HAVE A MAXIMUM OF 10% RECYCLED ASPHALT PAVEMENT (RAP). NO RECYCLED ASPHALT SHINGLES (RAS) ALLOWED IN WEARING COURSES.
3. ROOT BARRIER SHALL BE INSTALLED WITH ALL TRAILS ADJACENT TO WETLANDS AND OTHERWISE AS DIRECTED BY THE CITY ENGINEER IN ACCORDANCE WITH STR-19A.

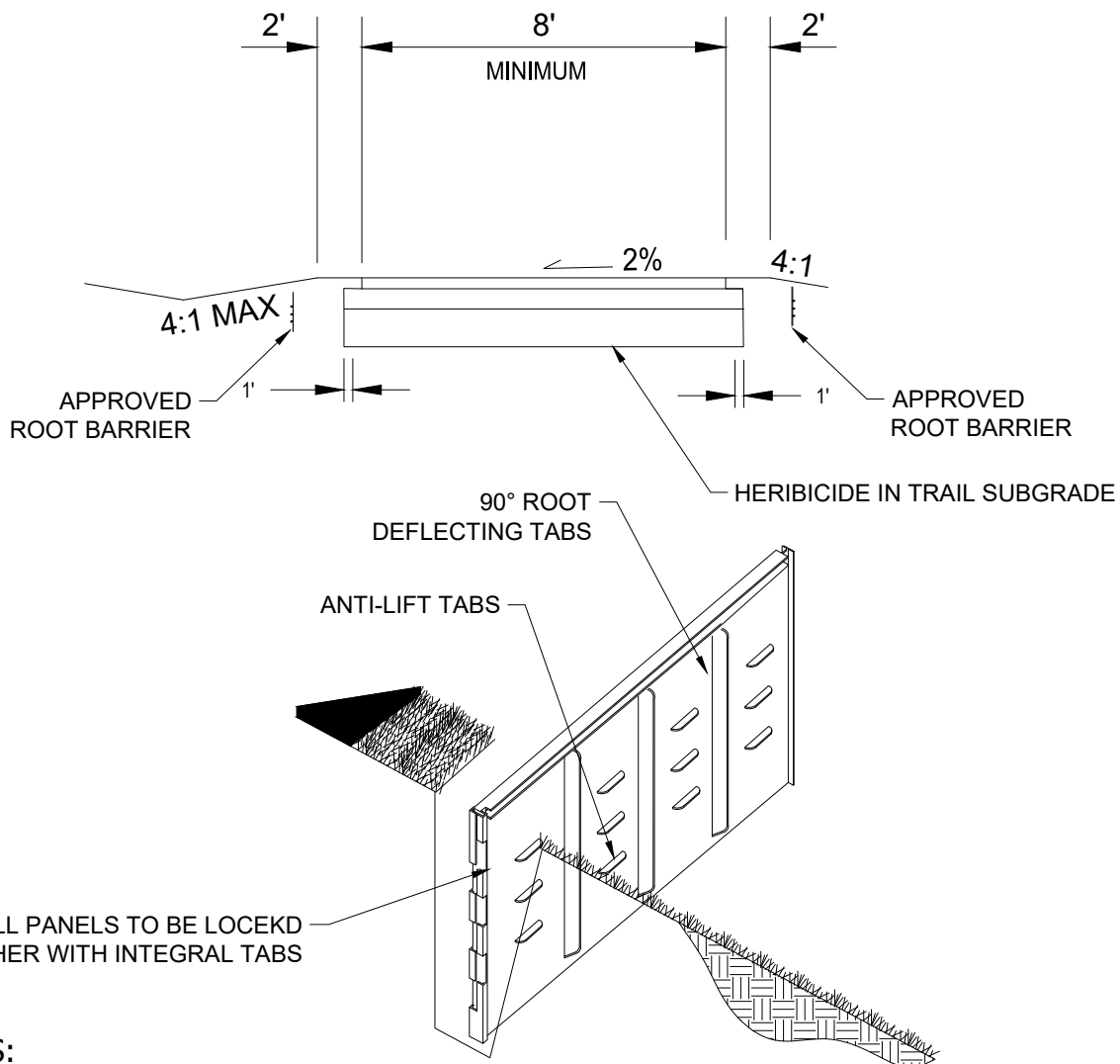

NOTES:

1. ROOT BARRIER USED SHALL BE 18" IN DEPTH, UNLESS OTHERWISE SPECIFIED IN CONTRACT. INSTALL ALONG TRAILS AS DIRECTED BY THE CITY ENGINEER.
2. ROOT BARRIERS SHALL BE PLACED SO THAT THE TOP EDGE SHALL BE LOCATED $\frac{1}{2}$ " BELOW FINISHED GRADE.
3. SIDE WITH TABS SHALL BE FACING VEGETATION.
4. INSTALL ROOT BARRIER 3' OFF EDGE OF TRAIL, TYP. PER MANUFACTURERS GUIDLINES AND CONTRACT DOCUMENTS.
5. WHEN INSTALLED ADJACENT TO EXISTING IMPROVED SURFACES, UTILIZE MEANS AND METHODS TO PROTECT THE EXISTING INFRASTRUCTURE FROM DAMAGE.
6. ROOT BARRIER SHALL BE MANUFACTURED BY DEEP ROOT PARTNERS OR APPROVED EQUAL.
7. MINIMUM 10' FROM TRAIL EDGE TO WETLAND BUFFER.

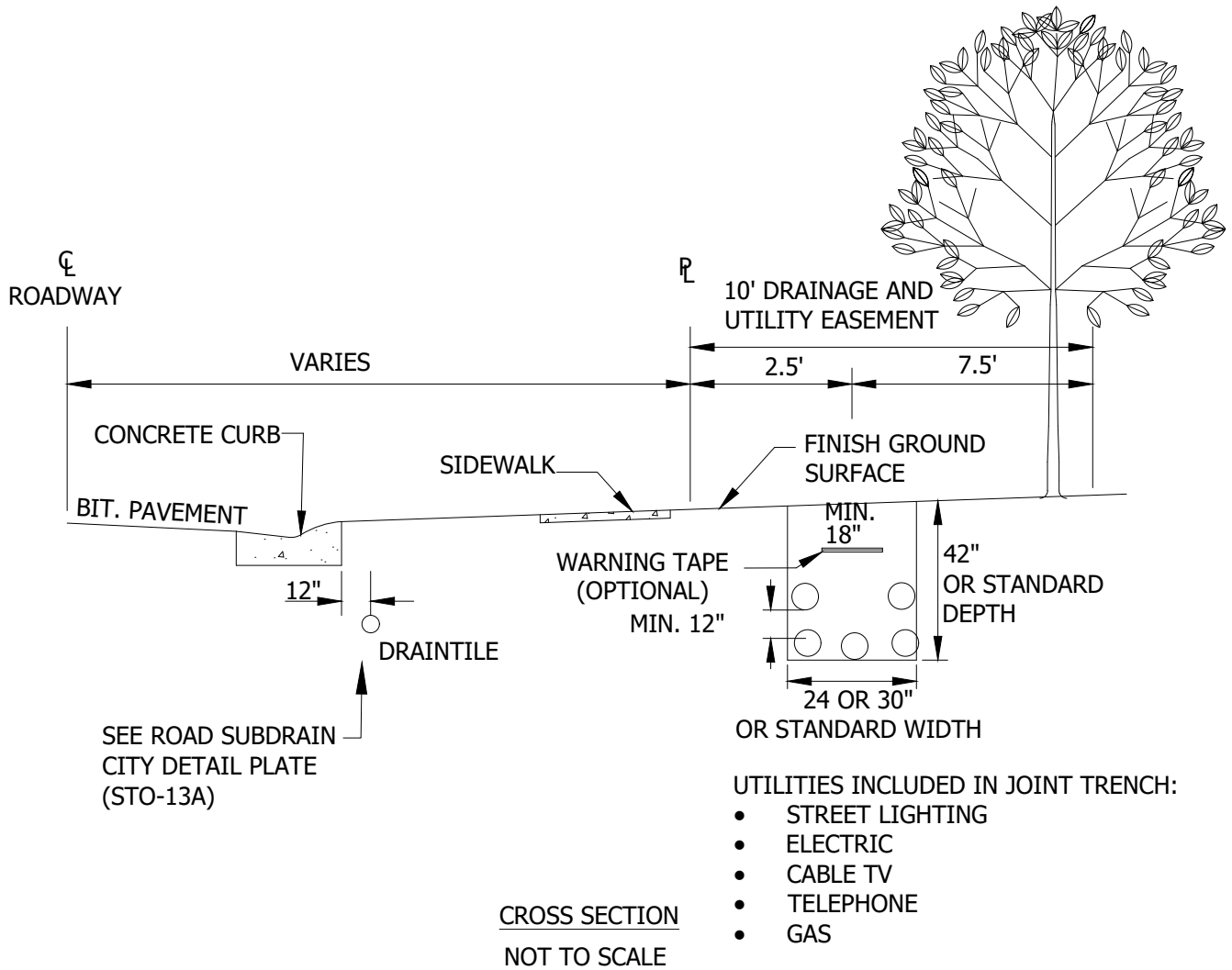

NOTE:

1. ALL CONDUIT CROSSINGS UNDER ROADWAYS SHALL BE THE CONTRACTORS RESPONSIBILITY TO INSTALL THE CORRECT SIZE AND NUMBER FOR ALL UTILITIES. THE CONTRACTOR SHALL ALSO INSTALL ONE ADDITIONAL CONDUIT CROSSING FOR FUTURE USE.
2. THE CITY REQUIRES JOINT TRENCHING FOR INSTALLATION OF UTILITIES WITHIN CITY UTILITY EASEMENTS. ALL TRENCHES SHALL BE COMPACTED.
3. ALL CURB STOPS AND BOXES WILL BE LOCATED 9' FROM THE PROPERTY LINE WITHIN THE DRAINAGE AND UTILITY EASEMENT.
4. STREET LIGHTS SHALL BE PLACED AS CLOSE TO 300' INTERVALS AS POSSIBLE IN RESIDENTIAL AREAS AND LOCATED ON PROPERTY CORNERS. ALL STREET LIGHT ELECTRICAL LINES SHALL BE RUGGEDIZED TYPE WIRING OR ENCASED IN CONDUIT AND PLACED WITHIN THE JOINT TRENCH.
5. ALL UTILITY BOXES SHALL BE PLACED ON COMMON PROPERTY CORNERS ON BACK SIDE OF DRAINAGE AND UTILITY EASEMENT.

NOTE: BARRICADE AS PER DAYTON
STANDARD DETAIL PLATE STR-31

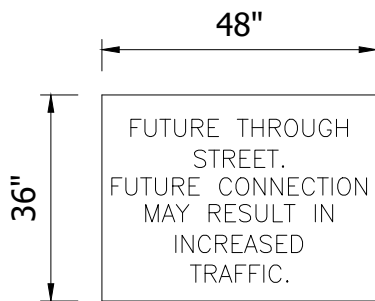
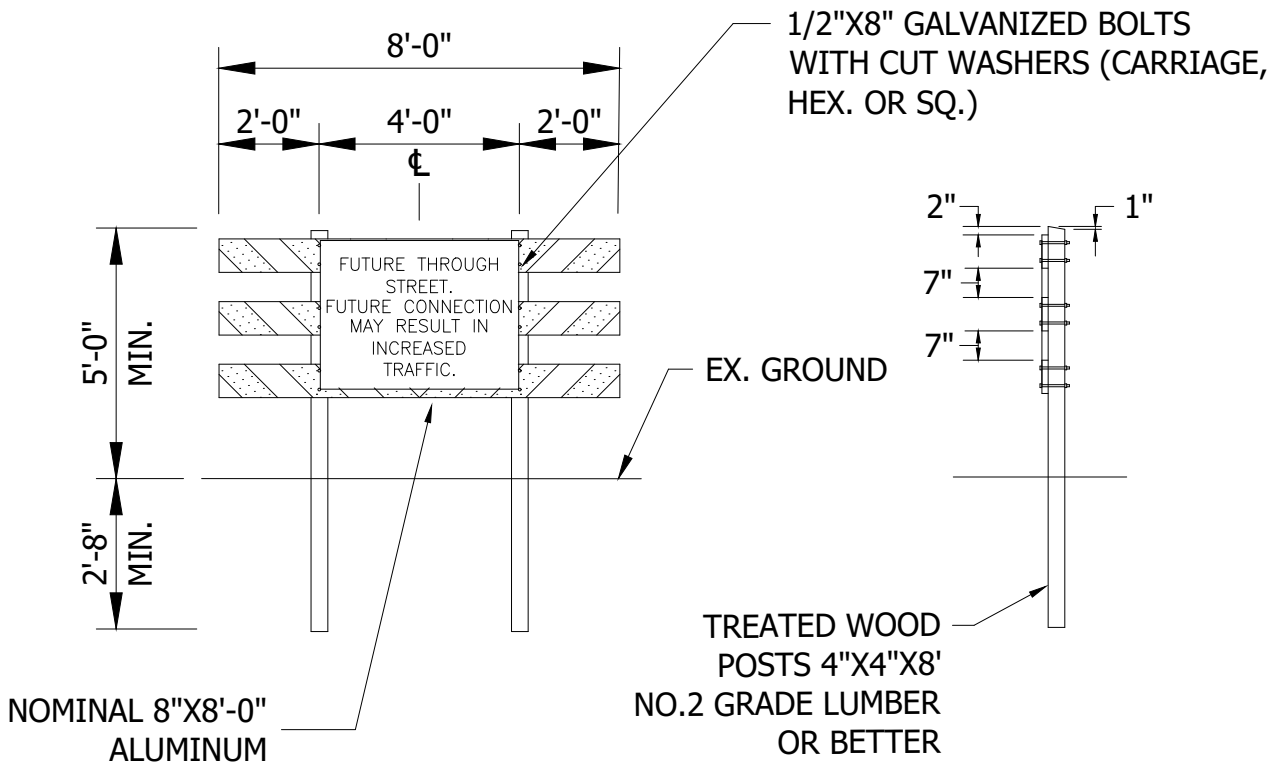

NOTES:

1. DESIGN SHALL CONFORM TO THESE REQUIREMENTS EXCEPT AS OTHERWISE APPROVED BY THE CITY ENGINEER.
2. SIGN SHALL BE REFLECTORIZED AS PER MNDOT 3352.2A.3B
3. SIGN SHALL BE CONSTRUCTED OF ALUMINUM PER MNDOT 3352.2A.1, BLACK ON WHITE WITH 4" LETTERS.

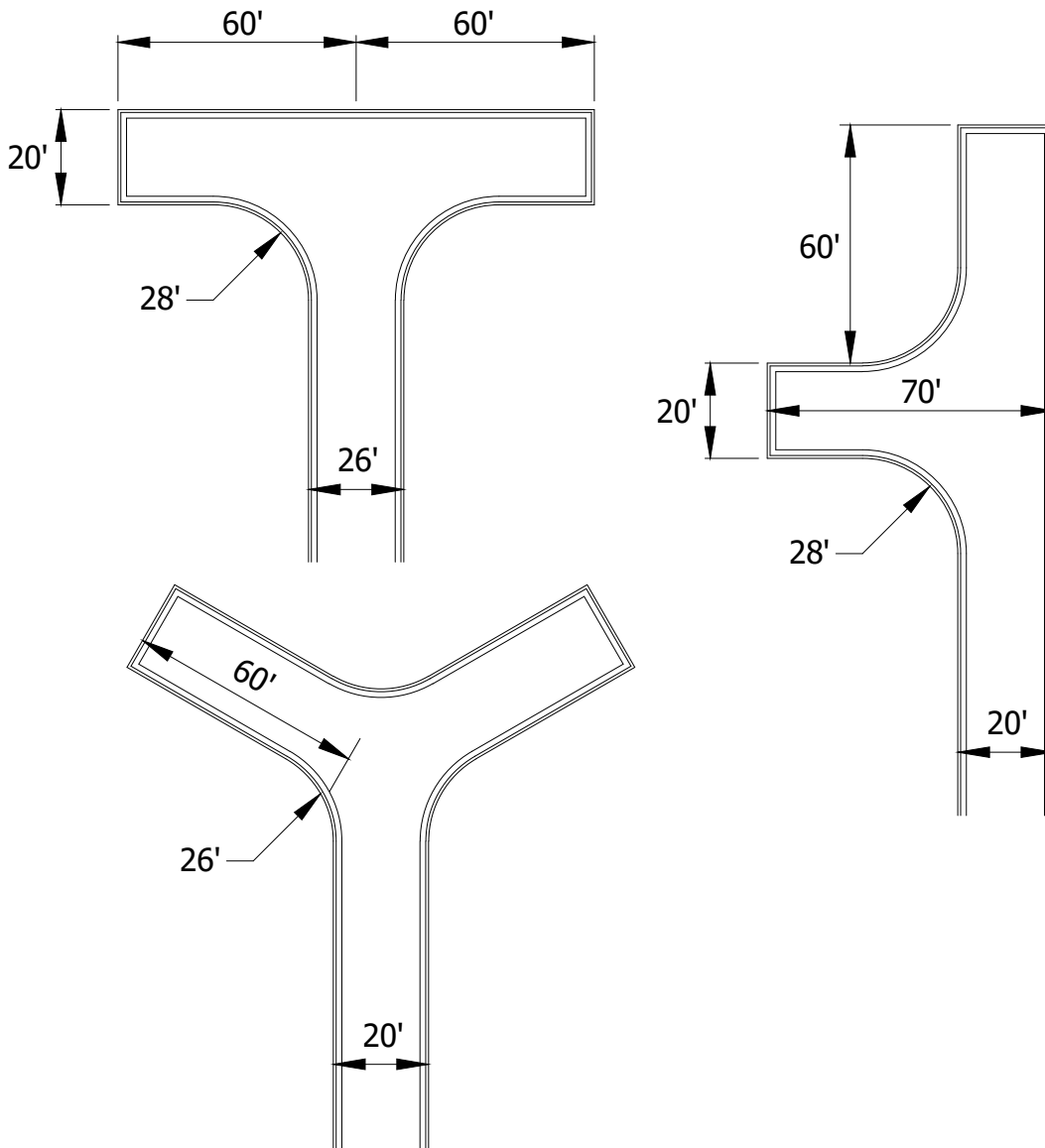

NOTES:

1. FIRE DEPARTMENT REQUIREMENTS FOR APPROVED ALTERNATE TURNAROUNDS ON FIRE DEPARTMENT ACCESS ROADS, AS REQUIRED BY MINNESOTA STATE FIRE CODE, 2020 EDITION.
2. TURNAROUNDS MAY BE SUBSTITUTED FOR CUL-DE-SACS IN PRIVATE DEVELOPMENTS WITH THE CITY ENGINEER'S APPROVAL.
3. CUL-DE-SAC TO BE CONSTRUCTED WITH A 45' RADIUS (MINIMUM).
4. NO BUILDING PERMITS SHALL BE ALLOWED UNTIL TURNAROUND HAS BEEN INSTALLED.
5. CURB & GUTTER SURROUNDING MAY BE ELIMINATED AT THE DISCRETION OF THE ENGINEER.

NOTES:

1. ALL NEW AND EXISTING WATER, SEWER SERVICE, AND CLEANOUT LOCATIONS SHALL BE MARKED IN CURB AS SHOWN. STAMPING OF SERVICE LOCATIONS SHALL BE CONSIDERED INCIDENTAL TO THE PRICE OF THE CURB.
2. STAMPS MAY BE BORROWED FROM THE CITY FOR A REFUNDABLE SECURITY DEPOSIT OF \$250 EACH.
3. W'S, S'S, AND Ⓞ'S NOT PLACED BY SPECIFIED STAMP WILL NOT BE ACCEPTED AND THAT SECTION OF CURB MUST BE REMOVED AND REPLACED.

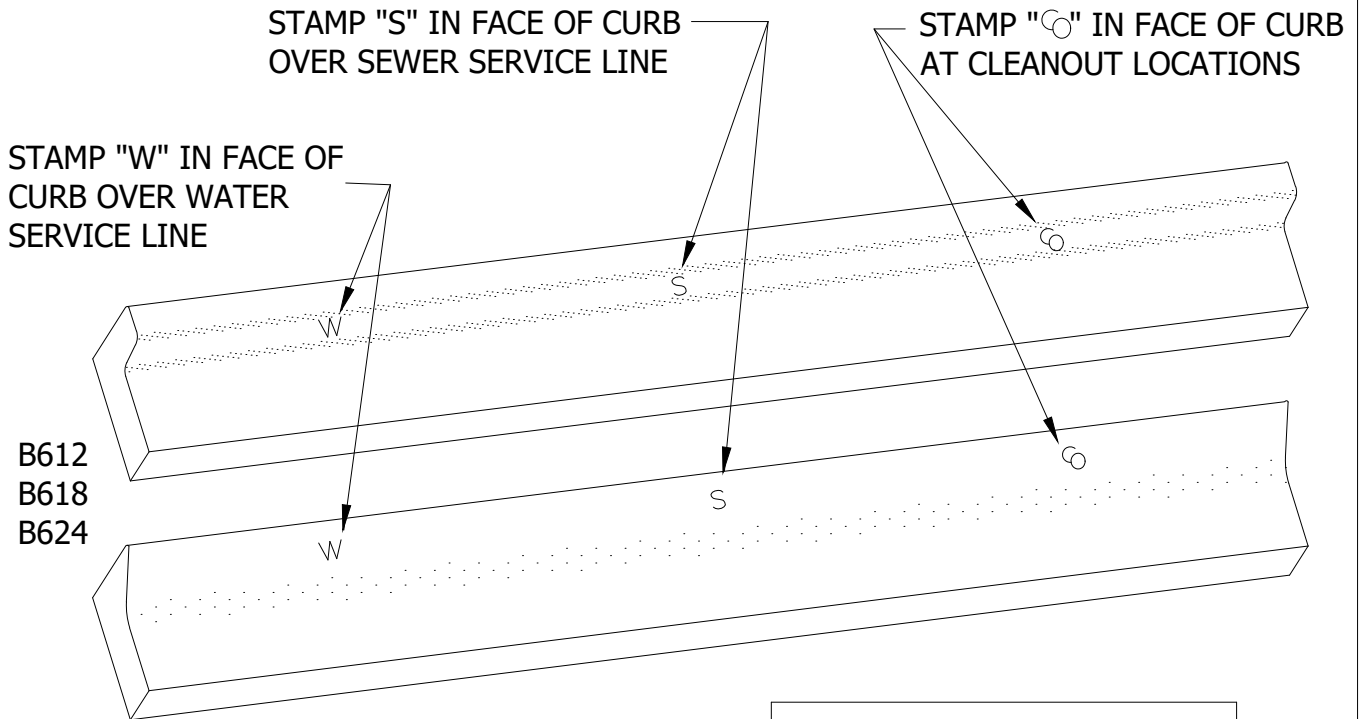

MOUNTABLE

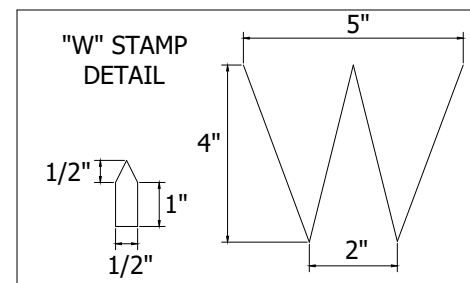
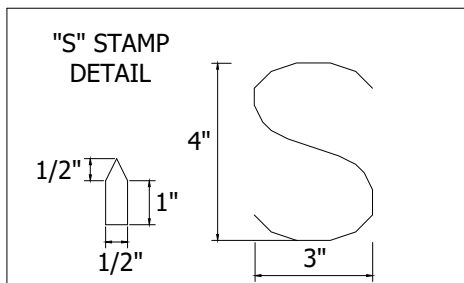
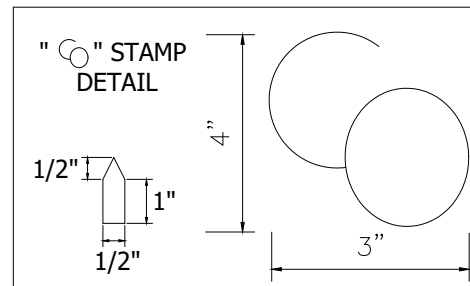

BITUMINOUS DRIVEWAY TYPICAL SECTION

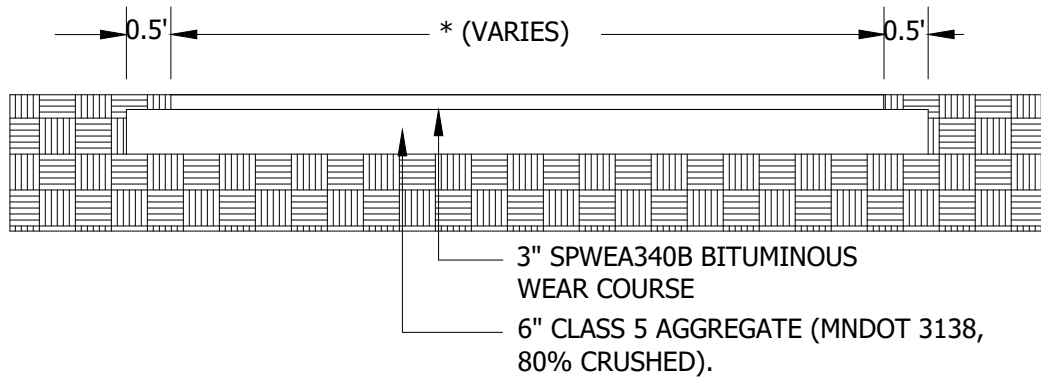

* DRIVEWAY WIDTH VARIES

CONCRETE DRIVEWAY TYPICAL SECTION

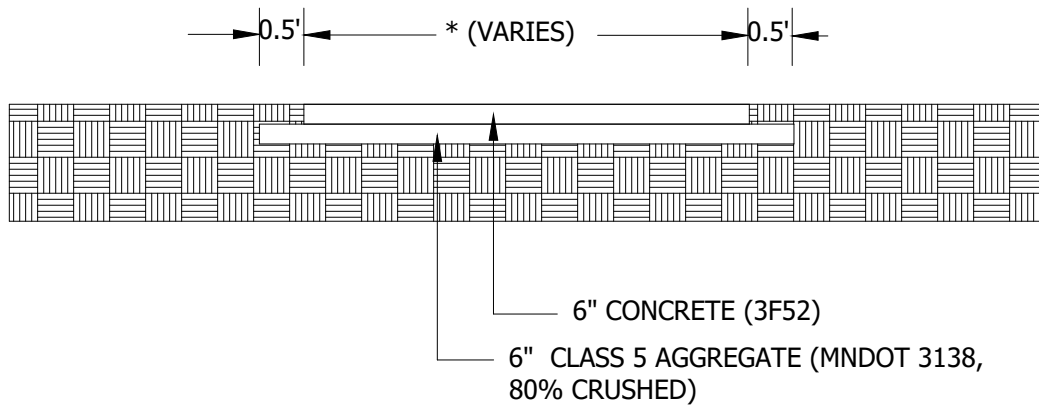

* DRIVEWAY WIDTH VARIES

AGGREGATE DRIVEWAY TYPICAL SECTION

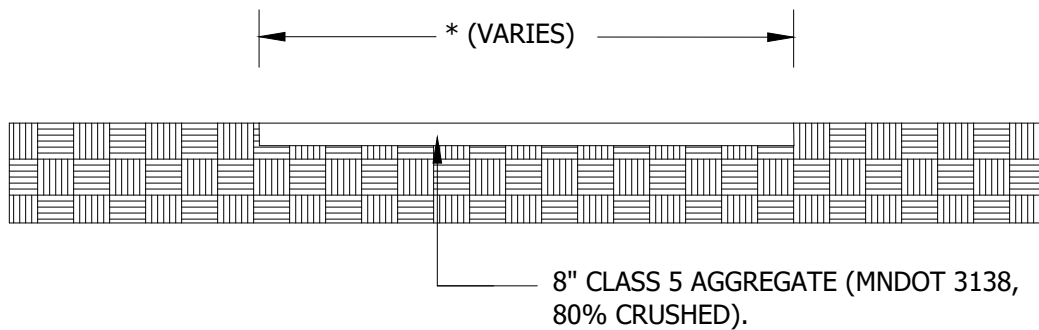

* DRIVEWAY WIDTH VARIES

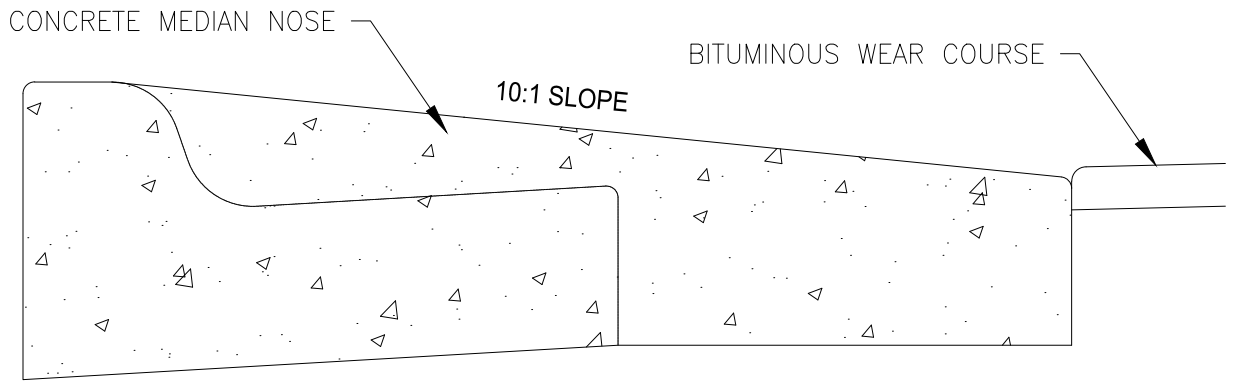

SECTION A-A

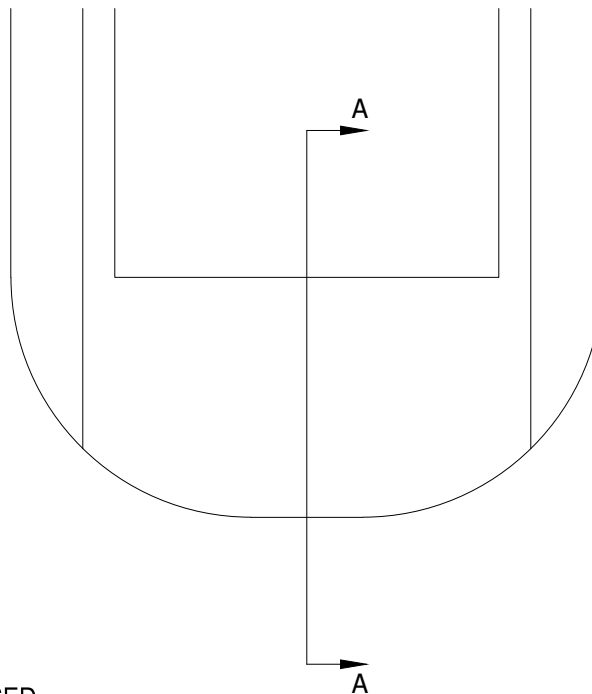

PLAN

NOTES:

1. RADIUS WILL VARY BASED ON ISLAND SIZE.
2. CONCRETE MEDIAN NOSE TO BE USED WHEN CENTER MEDIANS ARE PRESENT. COORDINATE WITH CITY ENGINEER.



2026 DETAIL PLATES
REV.1

CONCRETE MEDIAN NOSE

LAST REVISION:
OCT 2024

PLATE NO.
STR-25

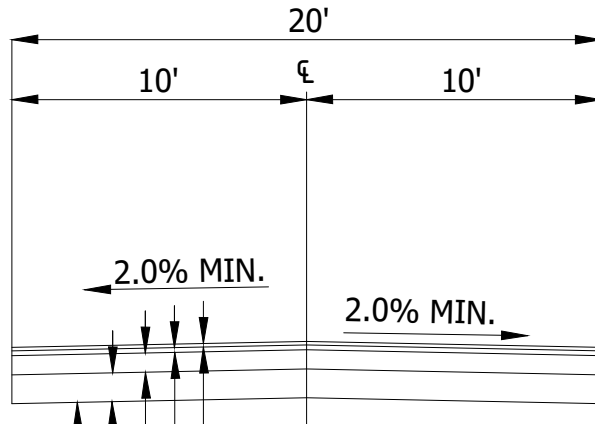

- 1 1/2"-TYPE SPWEA340B BITUMINOUS WEAR COURSE
- 2"-TYPE SPNWB330B BITUMINOUS BASE COURSE
- 8" CLASS 5 AGGREGATE BASE (MNDOT 3138, 80% CRUSHED)
- 12" MINIMUM SUBGRADE EXCAVATION AND SELECT GRANULAR BORROW (MNDOT 3149).
- GEOTEXTILE FABRIC TYPE V NON-WOVEN

NOTE:

1. TYPICAL SECTION SHOWN IS THE MINIMUM FIRE LANE REQUIREMENT. SEE SPECIFICATIONS FOR PROJECT SPECIFIC DETAILS.
2. DEMONSTRATE THAT TURN RADIUS REQUIREMENTS SET BY MINNESOTA STATE FIRE CODE, 2020 EDITION OR LATEST EDITION ARE MET.
3. THE CITY RESERVES THE RIGHT TO INCREASE THE ACCESS ROAD SECTION BASED ON SOIL CONDITIONS.



2026 DETAIL PLATES
REV.1

**FIRE APPARATUS ACCESS ROAD (FIRE LANE)
SECTION**

LAST REVISION:
DEC 2025

PLATE NO.
STR-26

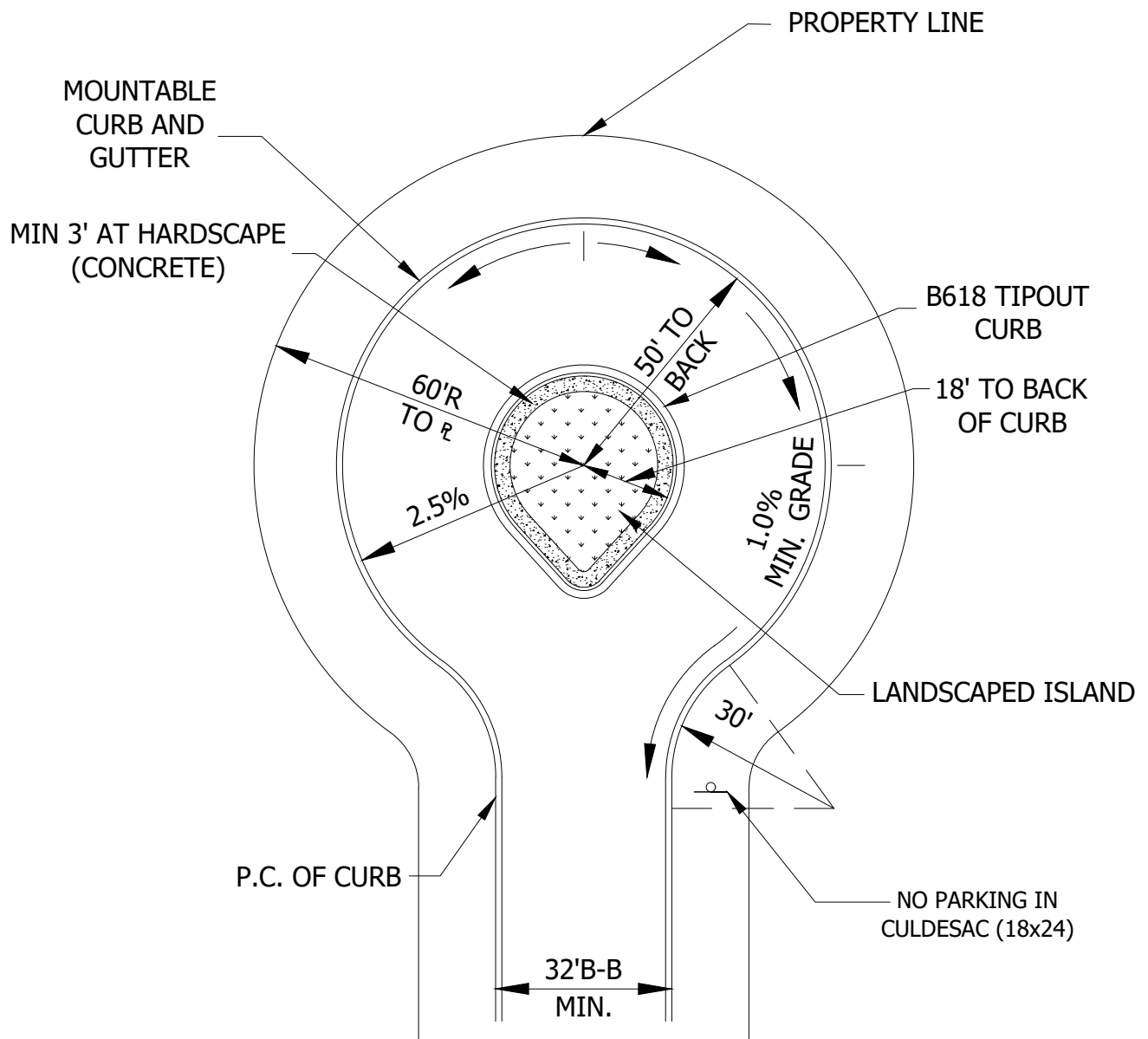

NOTE:

1. ALL RADIUS MEASUREMENTS TAKEN FROM FACE OF CURB UNLESS OTHERWISE STATED.
2. ALL CENTER ISLAND SURFACES MUST BE APPROVED BY THE CITY AND PRIVATELY MAINTAINED.
3. ON STREETS LONGER THAN 500' ENDING IN CULDESAC, A "NO OUTLET" (W14-2) SIGN IS REQUIRED AT THE START OF THE STREET.

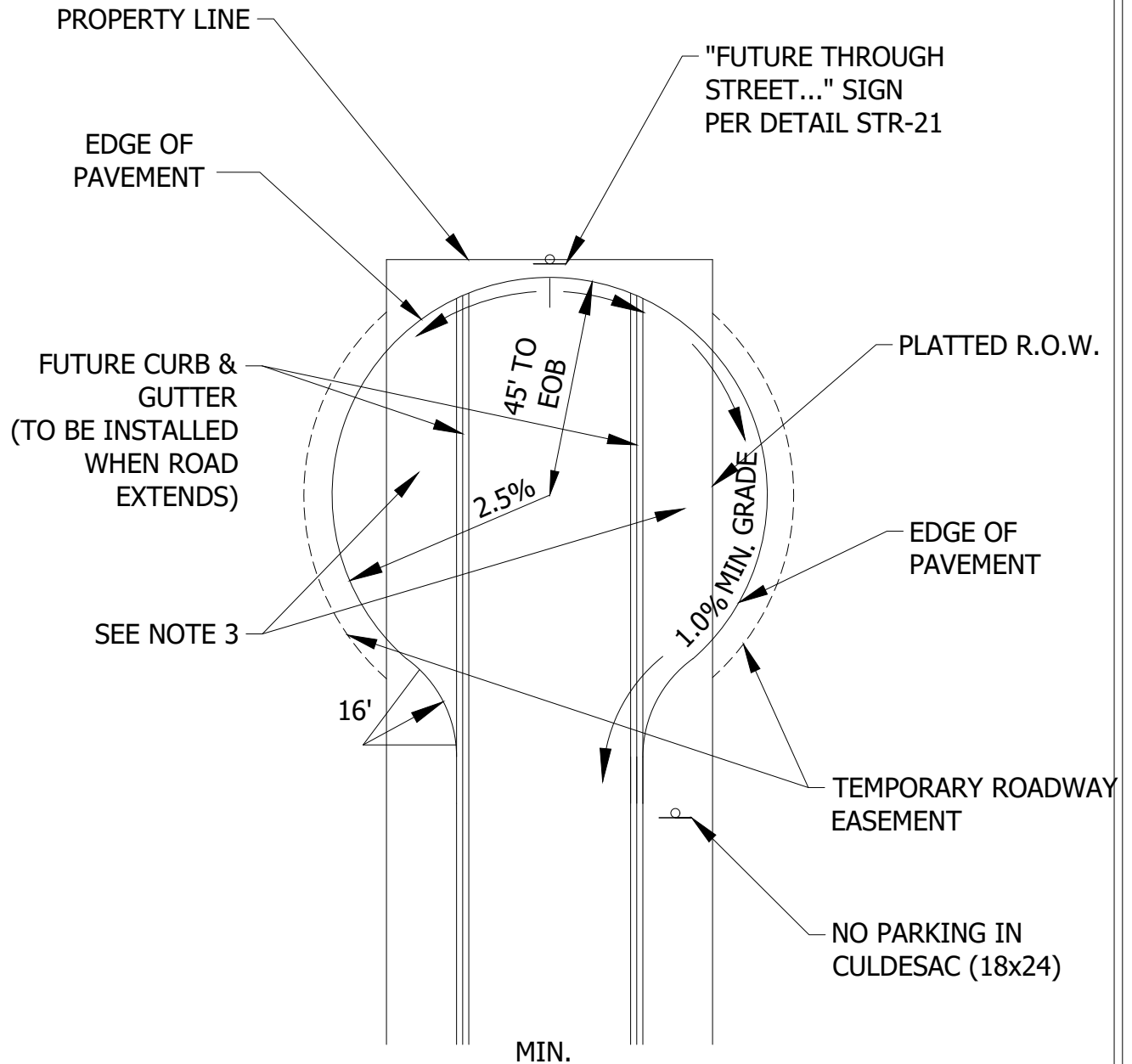

NOTE:

1. ALL RADIUS MEASUREMENTS TAKEN FROM FACE OF CURB.
2. NO BUILDING PERMIT WILL BE ALLOWED UNTIL TEMPORARY TURNAROUND IS INSTALLED.
3. TYPICAL SECTION FOR PAVED AREA OF TEMPORARY CUL-DE-SAC OUTSIDE OF FUTURE STREET SECTION TO BE 3" OF BITUMINOUS AND 12" OF AGGREGATE.

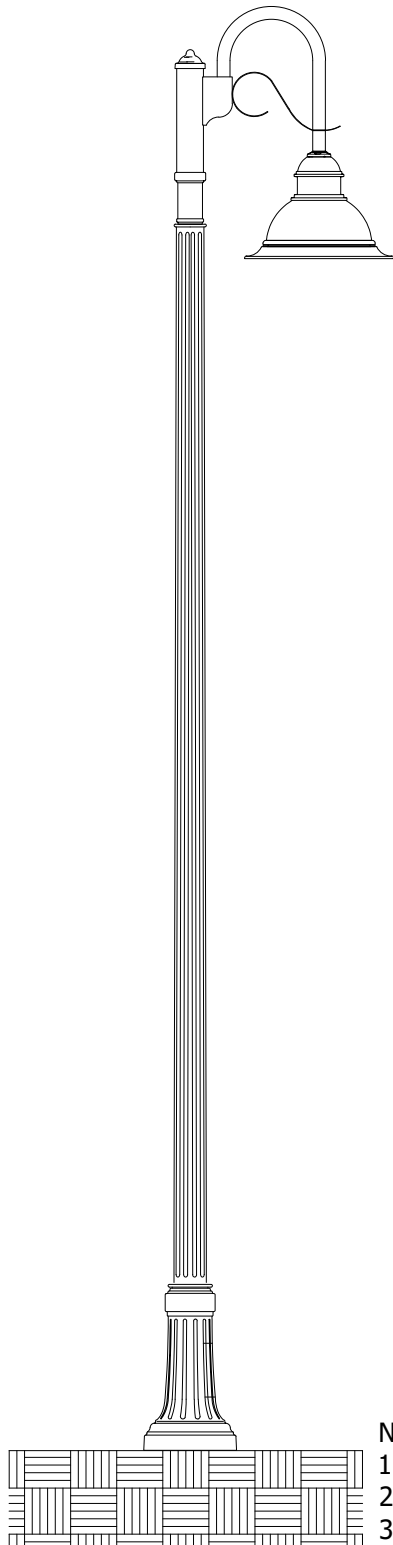

NOTES:

1. PROVIDE LIGHTING PLAN WITH IDENTIFIED PROPOSED LOCATION OF LIGHTS.
2. LIGHTING ACCESSORIES MAYBE ADDED BY THE CITY ENGINEER.
3. DOMUS STYLE LIGHTING WILL BE REQUIRED.

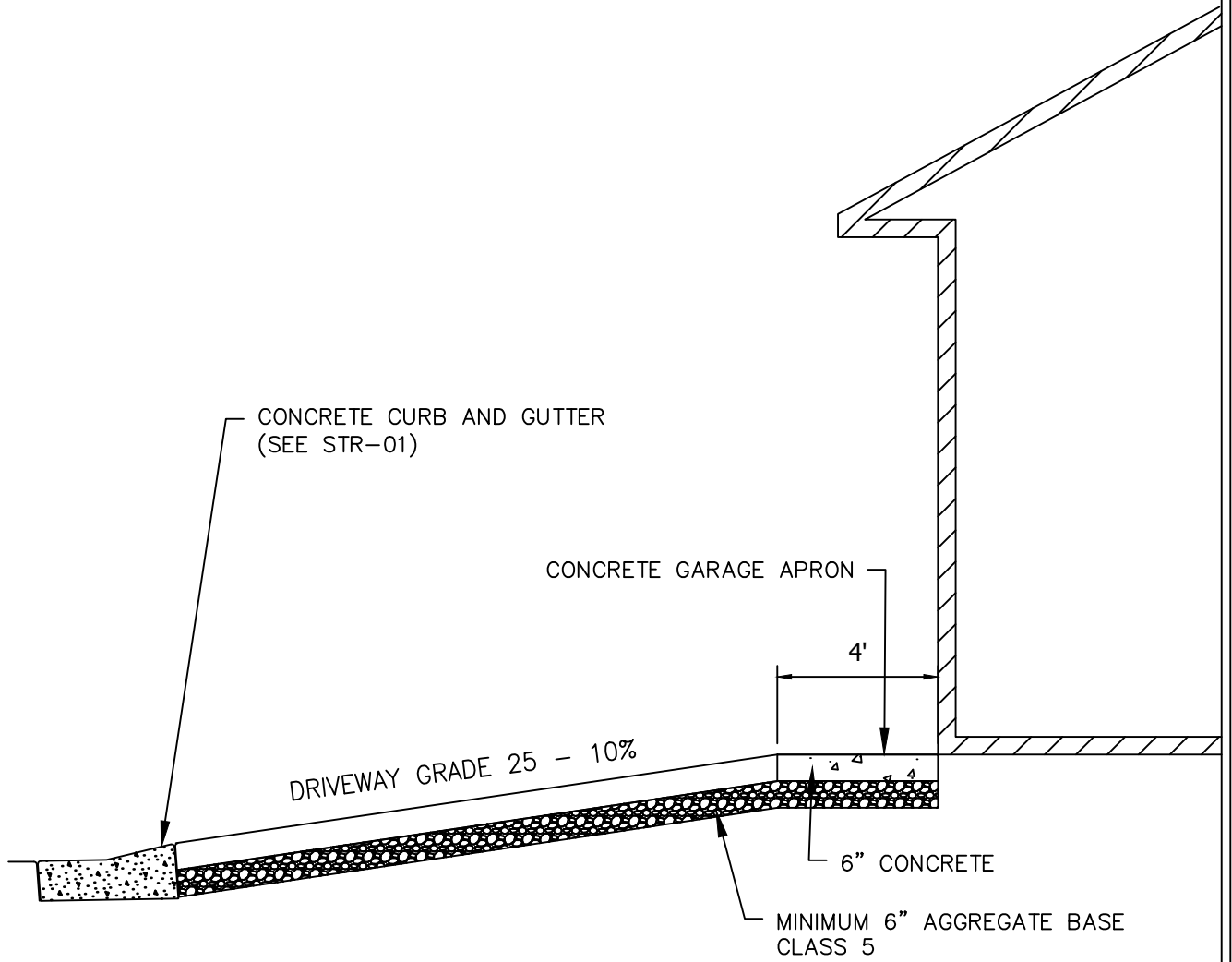

1. PANEL WIDTH SHALL NOT EXCEED 10 FEET WITHOUT A CONTRACTION JOINT.
2. JOINTING TO MATCH INTO DRIVEWAY JOINTING IF APPLICABLE.
3. MAXIMUM DRIVEWAY WIDTH = 28'.
4. MINIMUM DISTANCE FROM THE SIDE LOT LINE = 5' AS MEASURED FROM THE BACK OF CURB.
5. ALL DRIVEWAYS MUST BE AT LEAST 60' FROM INTERSECTIONS MEASURED FROM C-C TO CENTER OF DRIVEWAY.

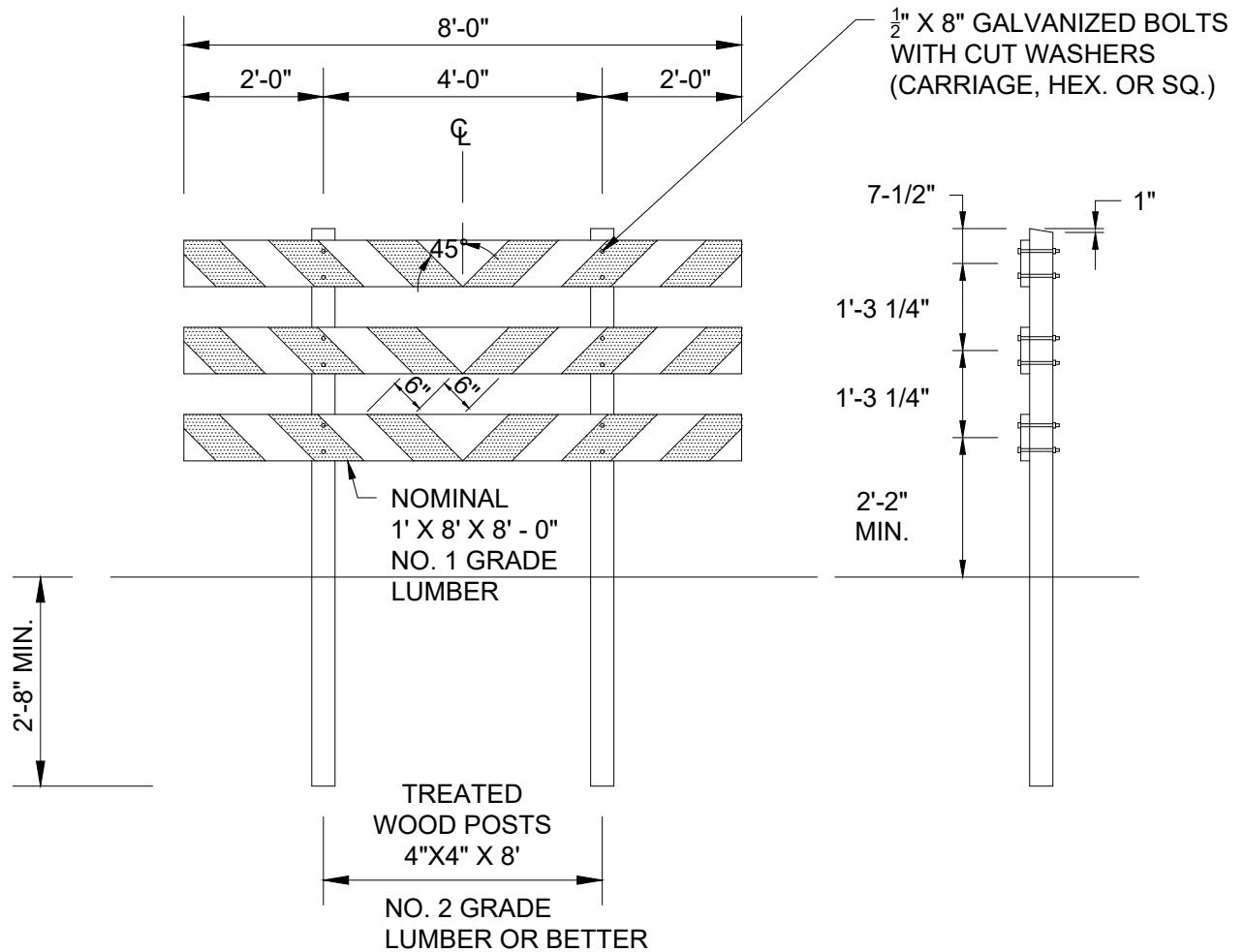

NOTE

THE BARRICADE BOARD FACE SURFACES SHALL BE FULLY REFLECTORIZED IN ALTERNATE SILVER-WHITE AND RED STRIPING, USING A REFLECTIVE SHEETING CONFORMING TO THE REQUIREMENTS OF SPEC. 3352.2A2B, STANDARD NO. 2.

PRIOR TO INSTALLING THE REFLECTIVE SHEETING, THE BARRICADE BOARDS SHALL BE GIVEN A COMPLETE COATING OF WHITE WOOD PRIMER PAINT FOLLOWED BY A SECOND COAT OF WHITE EXTERIOR APPLIED ONLY TO THE SURFACES NOT COVERED WITH REFLECTIVE SHEETING.

THE BARRICADE BOARDS SHALL BE COMPLETELY PAINTED AND REFLECTORIZED SHEETING APPLIED BEFORE BEING INSTALLED ON THE POSTS.

THE PLACEMENT OF THE BARRICADE SHALL BE 10'-0" FROM THE END OF THE BITUMINOUS ROAD WITH THE BARRICADE CENTERED ON THE ROADWAY FACING THE FLOW OF TRAFFIC.

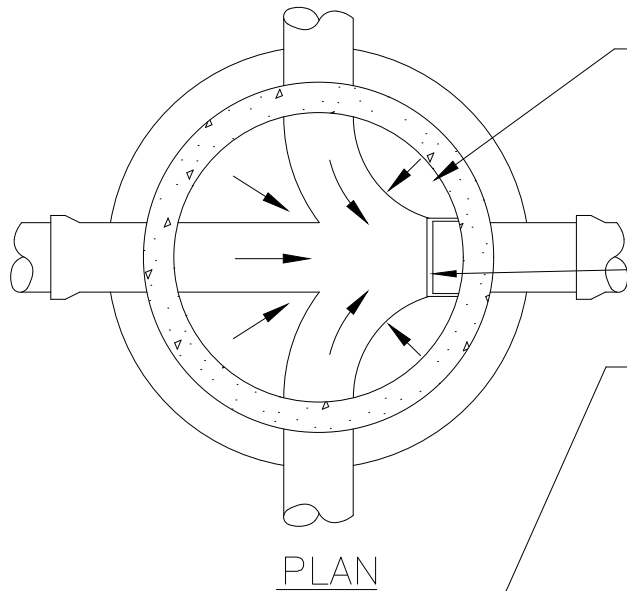

PRECAST INVERT MUST BE 1/2 DIAMETER OF PIPE AND BENCHES SHOULD BE SLOPED 2" TOWARD INVERT.

CASTING	A	B
R1642	27"	7"

MANHOLE STEPS SHALL BE PLACED SO THAT OFFSET VERTICAL PORTION OF CONE IS FACING DOWNSTREAM.

NEENAH FRAME AND COVER OR EQUAL LETTERED "SANITARY SEWER" WITH 2 CONCEALED PICK HOLES

MORTAR SHALL BE AIR ENTRAINED UNDERGROUND UTILITY MORTAR WHICH MEETS OR EXCEEDS ASTM C270 AND ASTM 387.

ONLY PLASTIC SHIMS SHALL BE ALLOWED IF NEEDED.

MINIMUM OF 4" AND MAXIMUM OF 12" OF CONCRETE ADJUSTMENT RINGS. THE TOP TWO RINGS MUST BE 2" RINGS. BETWEEN EACH RING THERE MUST BE A FULL BED OF MORTAR. 1 RING WITH MORTAR = 0.2'. INSTALL INTERIOR I & I BARRIER EULL'S OR APPROVED EQUAL. MUST OVERLAP CONE SECTION TO PREVENT SLIDING.

MANHOLE STEPS, NEENAH R1981J OR EQUAL, 16" ON CENTER.

GATOR WRAP SHALL BE REQUIRED ON BOTTOM JOINT AT A MINIMUM AND HIGHER PER DIRECTION OF THE ENGINEER.

ALL JOINTS IN MANHOLE TO HAVE "O" RING RUBBER GASKETS.

PLACE 3/4" RAM-NEK ON ALL SECTION JOINTS IF DIRECTED BY ENGINEER

PIPE SHALL BE CUT OUT FLUSH WITH INSIDE FACE OF WALL.

PRECAST INVERT REQUIRED.

KOR-N-SEAL MANHOLE OR APPROVED EQUAL CONSIDERED ACCEPTABLE ALTERNATE.

DOGHOUSES SHALL BE GROUTED ON INSIDE. AN A-LOCK GASKET SHALL BE USED AND NO EXTERNAL DOGHOUSE IS REQUIRED.

MINIMUM THICKNESS OF PRECAST BASE IS 6" FOR STRUCTURES 14' DEEP OR LESS, AND INCREASES 1" IN THICKNESS FOR EVERY 4' OF DEPTH GREATER THAN 14'.

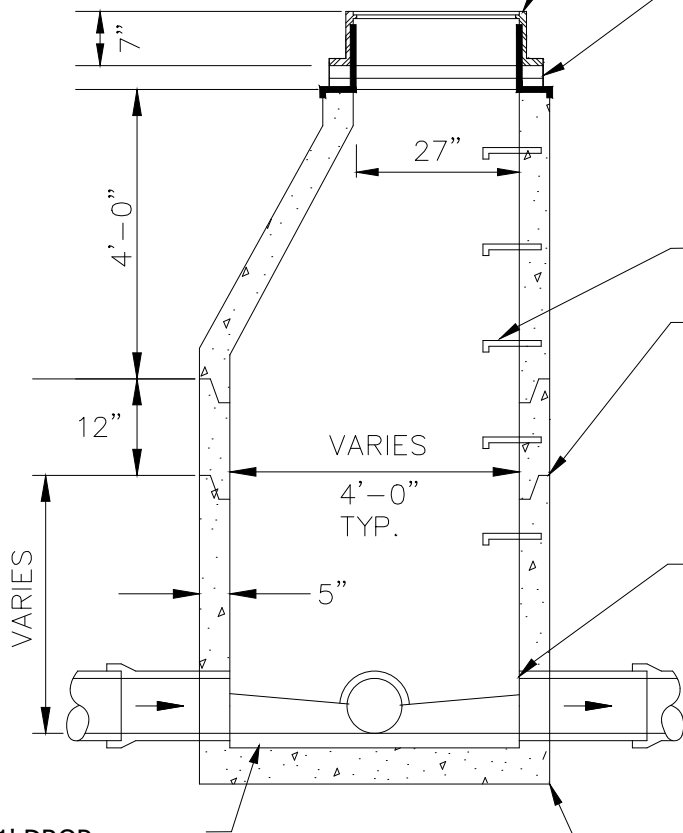

0.1' DROP BETWEEN INVERTS

SECTION

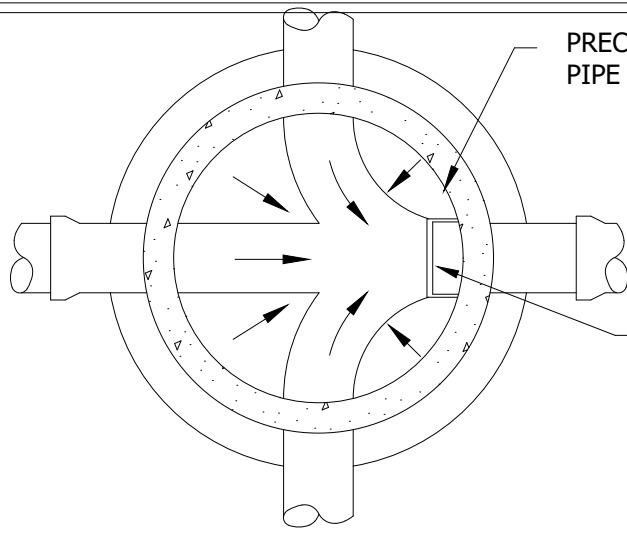

PRECAST INVERT MUST BE 1/2 DIAMETER OF THE PIPE AND THE BENCHES SLOPED 2" TOWARD INVERT.

CASTING	A	B
R1642	27"	7"

MANHOLE STEPS SHALL BE PLACED SO THAT OFFSET VERTICAL PORTION OF CONE IS FACING DOWNSTREAM.

MORTAR SHALL BE AIR ENTRAINED UNDERGROUND UTILITY MORTAR WHICH MEETS OR EXCEEDS ASTM C270 AND ASTM 387. ONLY PLASTIC SHIMS SHALL BE ALLOWED IF NEEDED.

PLAN

NEENAH FRAME AND COVER OR EQUAL, LETTERED "SANITARY SEWER", WITH 2 CONCEALED PICK HOLES.

MINIMUM OF 4" AND MAXIMUM OF 12" OF CONCRETE ADJUSTMENT RINGS. THE TOP TWO RINGS MUST BE 2" RINGS. BETWEEN EACH RING THERE MUST BE A FULL BED OF MORTAR. 1 RING WITH MORTAR = 0.2'. INSTALL INTERIOR I & I BARRIER EULL'S OR APPROVED EQUAL. MUST OVERLAP CONE SECTION TO PREVENT SLIDING.

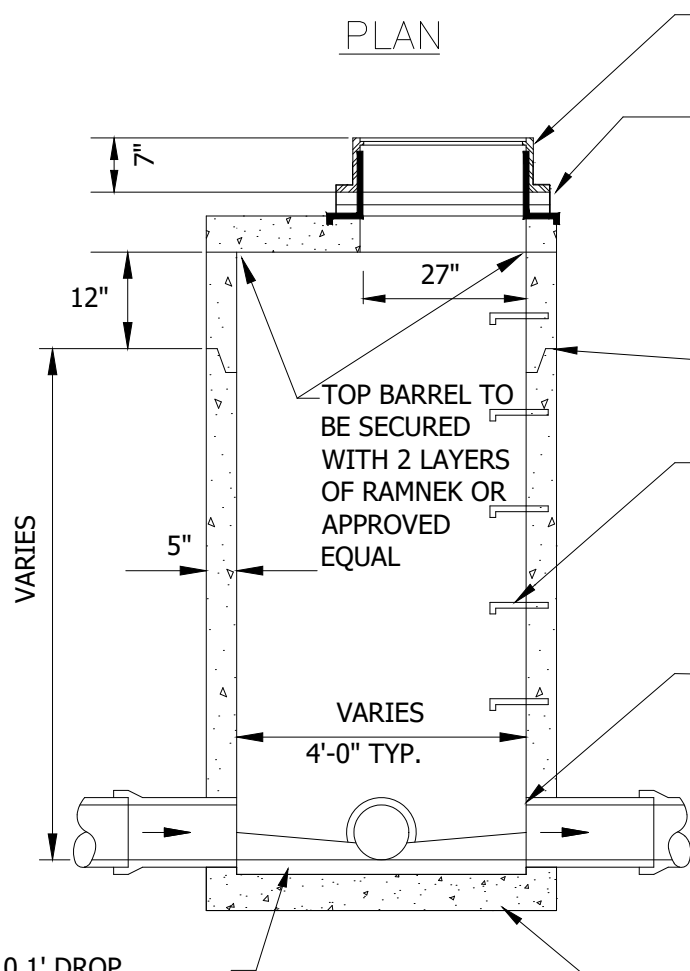

GATOR WRAP SHALL BE REQUIRED ON BOTTOM JOINT AT A MINIMUM OR HIGHER PER DIRECTION OF THE ENGINEER.

MANHOLE STEPS, NEENAH R1981J OR EQUAL, 16" ON CENTER.

ALL JOINTS IN MANHOLE TO HAVE "O" RING RUBBER GASKETS.

PLACE 3/4" RAM-NEK ON ALL SECTION JOINTS IF DIRECTED BY ENGINEER.

PIPE SHALL BE CUT OUT FLUSH WITH INSIDE FACE OF WALL.

PRECAST INVERT IS REQUIRED.

NOTE: KOR-N-SEAL MANHOLE OR APPROVED EQUAL CONSIDERED ACCEPTABLE ALTERNATE.

DOGHOUSES SHALL BE GROUTED ON INSIDE. A LOCK GASKET SHALL BE USED AND NO EXTERNAL DOGHOUSE IS REQUIRED.

0.1' DROP BETWEEN INVERTS

SECTION

MINIMUM THICKNESS OF PRECAST BASE IS 6" FOR STRUCTURES 14' DEEP OR LESS, AND INCREASES 1" FOR EVERY 4' OF DEPTH GREATER THAN 14' DEEP.

INSIDE OF MANHOLE

INSIDE OF MANHOLE SHALL BE LINED WITH GSE STUDLINE, T-LOCK OR EQUIVALENT LINER

MORTAR SHALL BE AIR ENTRAINED UNDERGROUND UTILITY MORTAR WHICH MEETS OR EXCEEDS ASTM C270 AND ASTM 387. ONLY PLASTIC SHIMS SHALL BE ALLOWED IF NEEDED.

DIP TO BE MADE IN USA OR CANADA, FITTINGS TO BE EPOXY BONDED, ALL DIP TO BE LINED WITH PROTECTO 401 LINER OR APPROVED EQUAL

CASTING	A	B
R1642	27"	7"

DROP INLET IS REQUIRED WHEN THE DROP IS 2FT OR GREATER

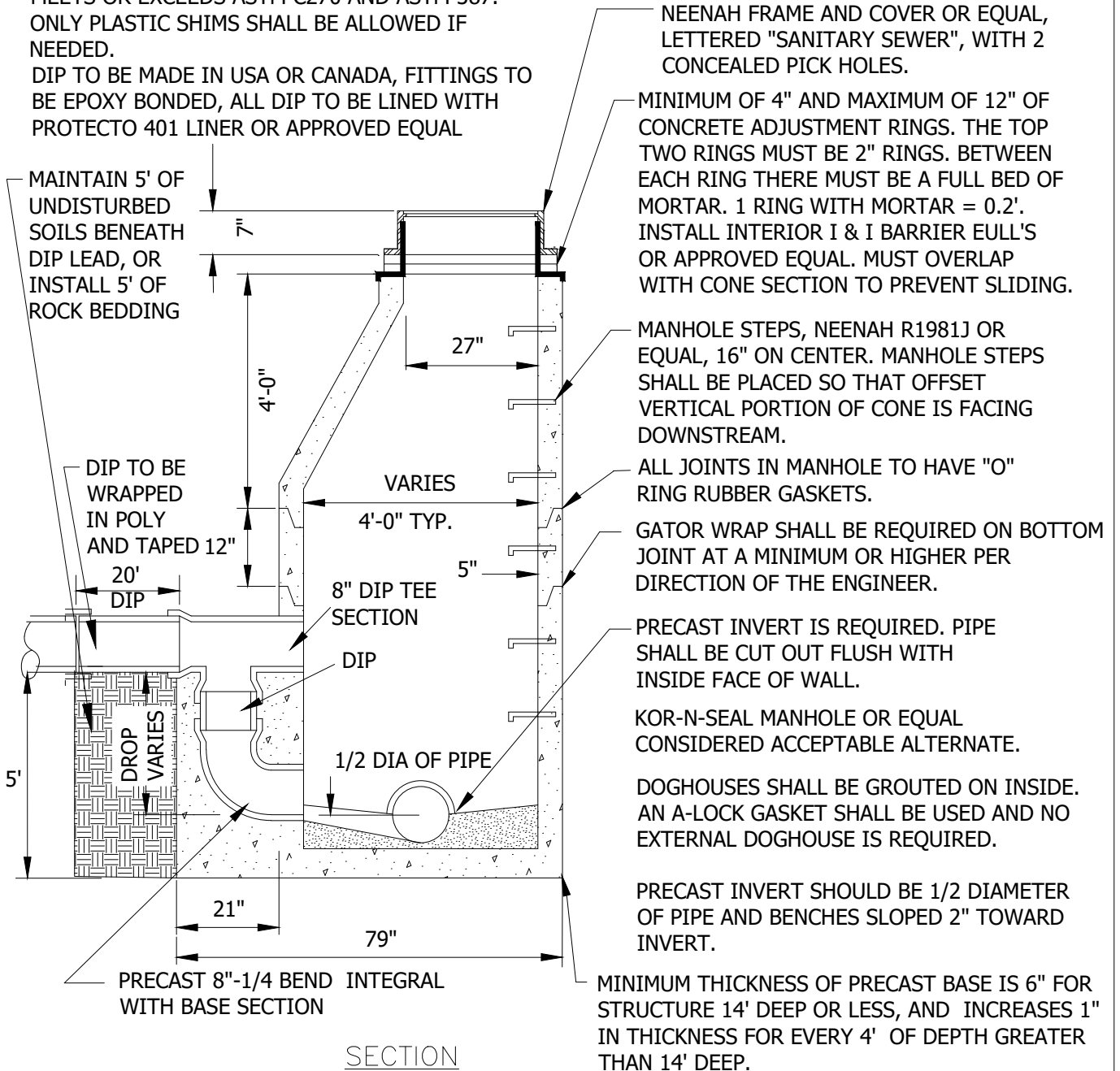

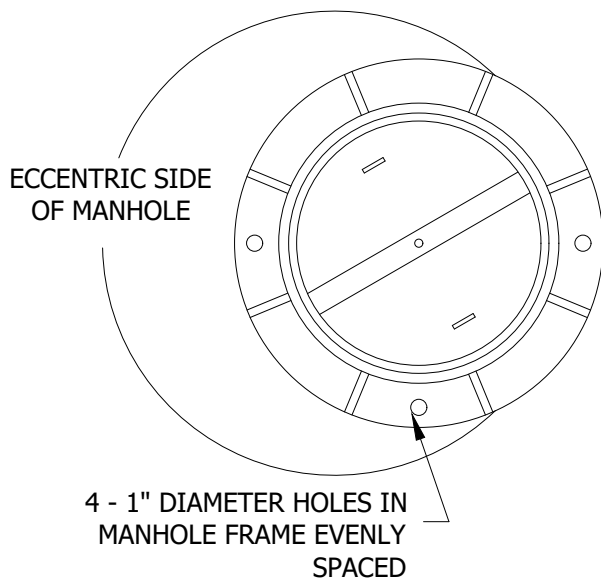

PLAN VIEW TOP COVER REMOVED

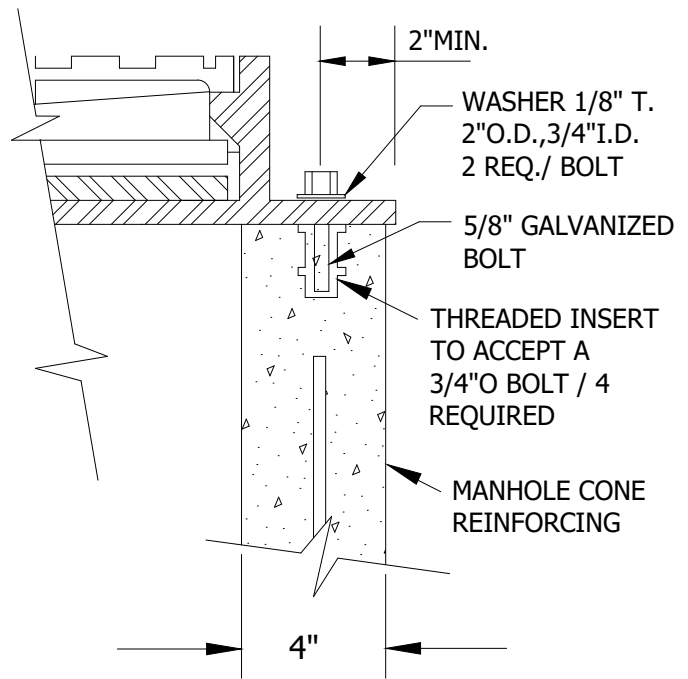

TIE DOWN DETAIL

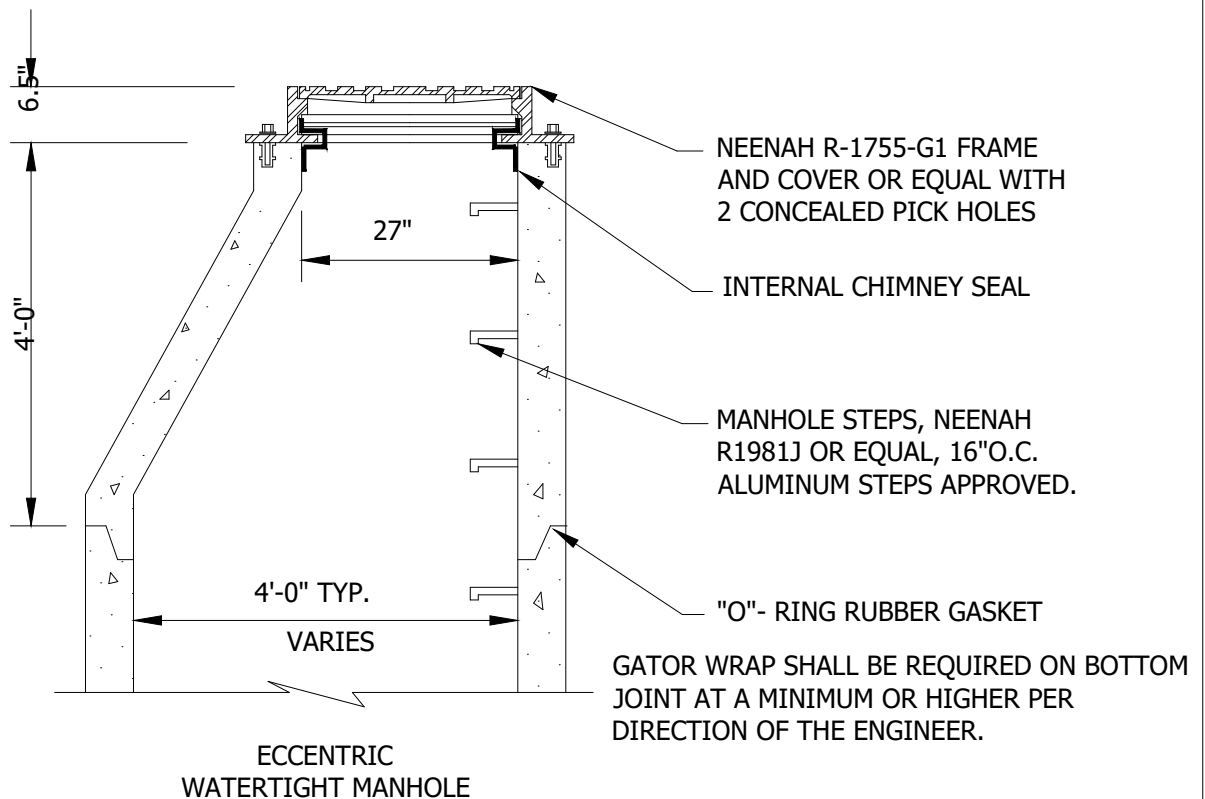

PLACE 3/4" RAM-NEK ON ALL SECTION JOINTS.

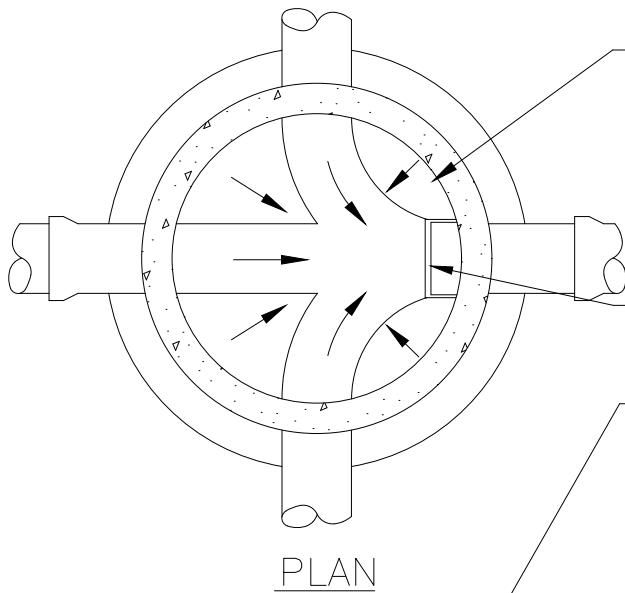

HEIGHT OF THE BENCH MUST EQUAL THE DIAMETER OF THE PIPE AND BENCHES SHOULD BE SLOPED 2" TOWARD INVERT.

CASTING	A	B
R1642	27"	7"

MANHOLE STEPS SHALL BE PLACED SO THAT OFFSET VERTICAL PORTION OF CONE IS FACING DOWNSTREAM.

NEENAH FRAME AND COVER OR EQUAL LETTERED "SANITARY SEWER" WITH 2 CONCEALED PICK HOLES

MORTAR SHALL BE AIR ENTRAINED UNDERGROUND UTILITY MORTAR WHICH MEETS OR EXCEEDS ASTM C270 AND ASTM 387. ONLY PLASTIC SHIMS SHALL BE ALLOWED IF NEEDED.

MINIMUM OF 4" AND MAXIMUM OF 12" OF CONCRETE ADJUSTMENT RINGS. THE TOP TWO RINGS MUST BE 2" RINGS. BETWEEN EACH RING THERE MUST BE A FULL BED OF MORTAR. 1 RING WITH MORTAR = 0.2'. INSTALL INTERIOR I & I BARRIER EULL'S OR APPROVED EQUAL. MUST OVERLAP CONE SECTION TO PREVENT SLIDING.

MANHOLE STEPS, NEENAH R1981J OR EQUAL, 16" ON CENTER.

GATOR WRAP SHALL BE REQUIRED ON BOTTOM JOINT AT A MINIMUM AND HIGHER PER DIRECTION OF THE ENGINEER.

ALL JOINTS IN MANHOLE TO HAVE "O" RING RUBBER GASKETS.

PLACE 3/4" RAM-NEK ON ALL SECTION JOINTS IF DIRECTED BY ENGINEER

PRECAST INVERT REQUIRED. PIPE SHALL BE CUT OUT FLUSH WITH INSIDE FACE OF WALL. KOR-N-SEAL MANHOLE OR APPROVED EQUAL CONSIDERED ACCEPTABLE ALTERNATE.

DOGHOUSES SHALL BE GROUTED ON INSIDE. AN A-LOCK GASKET SHALL BE USED AND NO EXTERNAL DOGHOUSE IS REQUIRED.

MINIMUM THICKNESS OF PRECAST BASE IS 6" FOR STRUCTURES 14' DEEP OR LESS, AND INCREASES 1" IN THICKNESS FOR EVERY 4' OF DEPTH GREATER THAN 14'. VARIANCE TO THIS REQUIREMENT MAY BE CONSIDER IF SIGNED OFF BY CERTIFICATED STRUCTURAL ENGINEER.

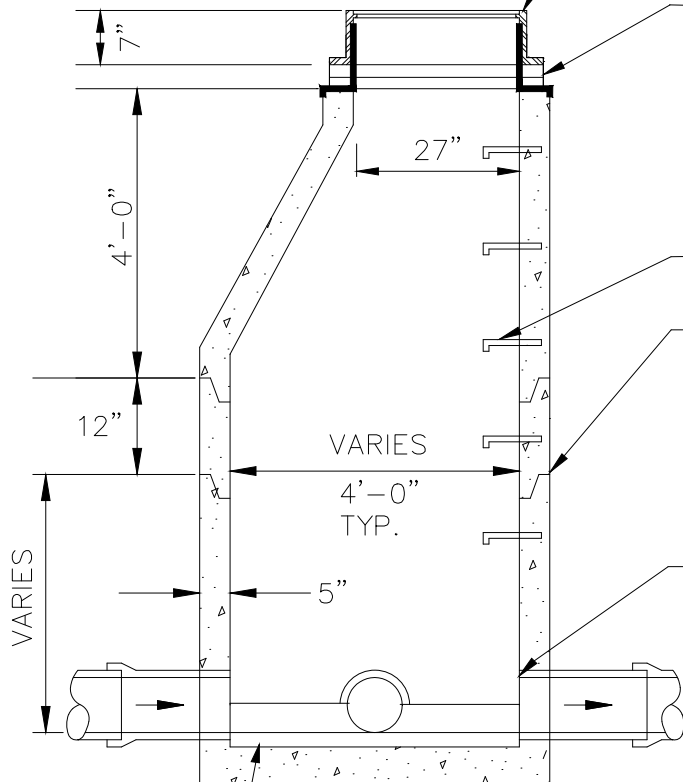

NO DROP BETWEEN INVERTS WHERE PIPES ARE GREATER THAN 120° APART.

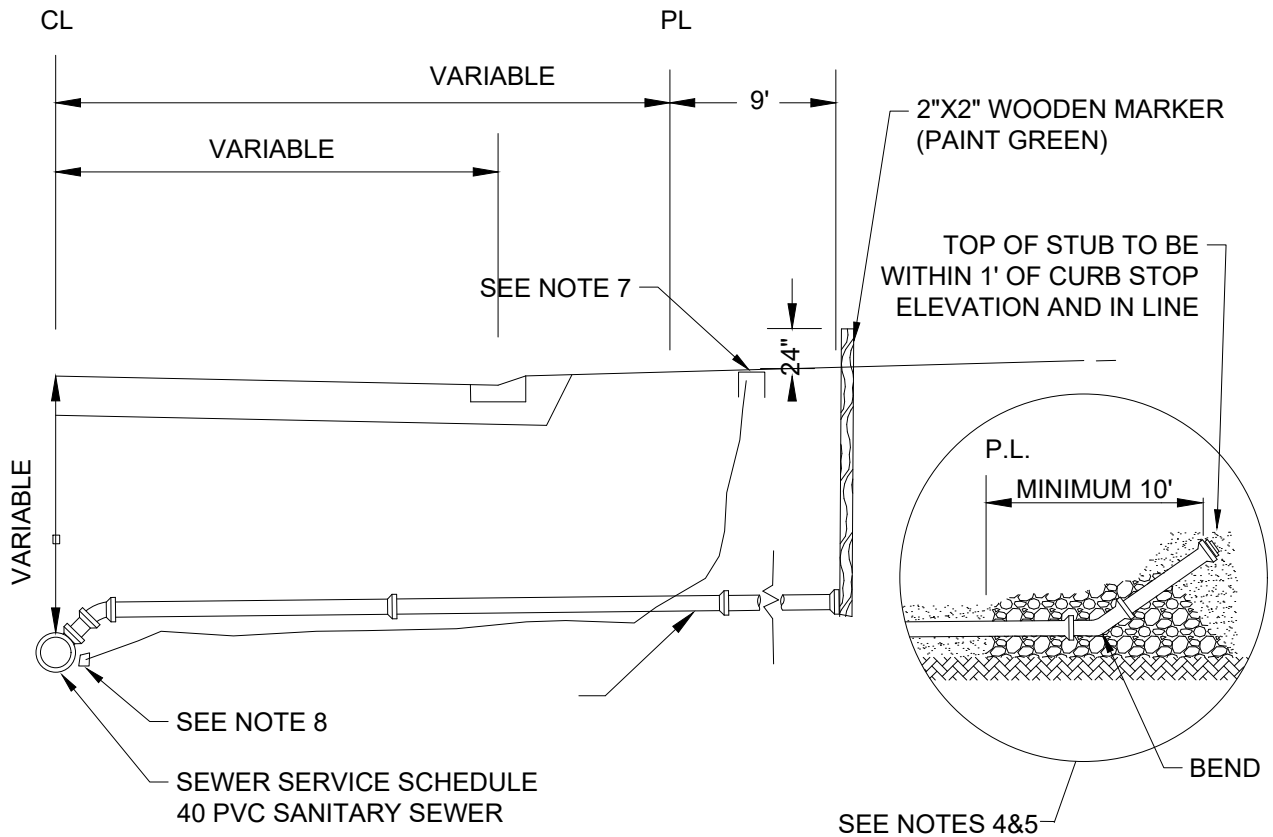

NOTES:

1. SEWER SERVICES. 4" (UNLESS OTHERWISE SPECIFIED ON PLANS) SCHEDULE 40 PVC SEWER PIPE
2. PIPE JOINTS SHALL BE NON GASKETED, SOLVENT WELD TYPE.
3. SLOPE $\frac{1}{4}$ " PER FOOT MINIMUM.
4. ALL PIPE SHALL BE BEDDED IN GRANULAR BORROW 3149.2B1 EXCEPT THE LAST TEN FEET WHERE COARSE FILTER AGGREGATE (3149.2H) WILL BE REQUIRED.
5. 45 DEGREE BENDS SHALL BE USED AT THE END OF THE SERVICE IF DEPTH EXCEEDS 8' TO BRING SANITARY SERVICE INVERT TO CURBSTOP ELEVATION.
6. INSTALL SANITARY RISER TO BE WITHIN 1' OF CURB STOP ELEVATION.
7. TRACER WIRE SHALL BE BROUGHT UP ALONG WATERMAIN CURB STOP. INSTALL VALVCO, SNAKEPIT, OR APPROVE EQUAL TRAFFIC RATED TRACER WIRE ACCESS BOX WITH 2 LUGS.
8. MIN OF 1 LB. DRIVE IN ANODES WITH MIN 20' WIRE LEAD ARE TO BE INSTALLED AT EVERY SANITARY SERVICE WYE.
9. TRACER WIRE SHALL BE 12 AWG COPPER CLAD STEEL ORE WIRE WITH MIN BREAK LOAD OF 450 LB FOR OPEN CUT INSTALLATION RATED FOR 30 VOLTS. MIN 45 MIL HMWPE JACKET
10. TRACER WIRE CONNECTOR SHALL BE DRY CONN DIRECT BURY LUG AQUA, PRO-TRACE DB OR APPROVED EQUAL.

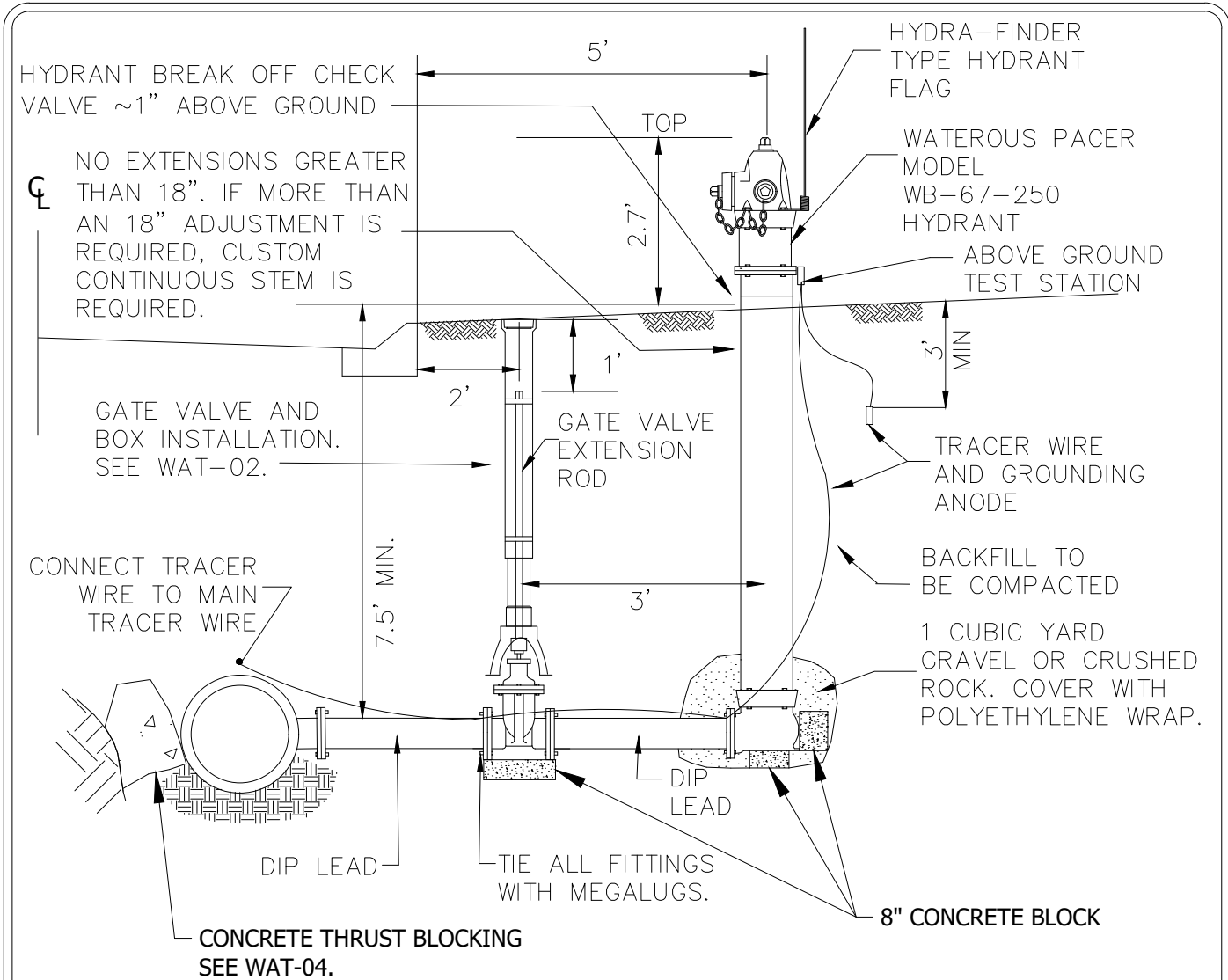

NOTE:

1. FACTORY INSTALLED PLUGS REQUIRED WHENEVER HYDRANTS ARE INSTALLED IN AREAS WITH HIGH GROUNDWATER LEVEL, AS DETERMINED BY DEWATERING REQUIREMENTS AND THE CITY ENGINEER. THE MAIN NOZZLE SHALL BE PAINTED BLUE FOR ALL HYDRANTS WITH PLUGGED DRAIN HOLES.
2. ALL DUCTILE IRON WATERMAIN FITTINGS SHALL BE FUSION BONDED EPOXY COATED, POLYWRAPPED, AND TAPED.
3. HYDRANTS SHALL BE MARKED WITH STAINLESS STEEL TAG FROM FACTORY.
4. CONTRACTOR SHALL SUPPLY TWO HYDRANT FLAGS, ONE TO BE INSTALLED ON THE HYDRANT AND THE SECOND DELIVERED TO THE DAYTON PUBLIC WORKS FACILITY.
5. ALL HYDRANT LEADS ARE TO BE CONSTRUCTED WITH POLYWRAPPED DIP, CLASS 52.
6. ALL WATERMAIN BOLTS SHALL BE COR-BLUE OR APPROVED EQUAL.
7. HYDRANTS SHALL BE PAINTED IN ACCORDANCE WITH THE FOLLOWING SCHEDULE: FLOW RATE OF 1,000 GPM OR MORE - GREEN; FLOW RATE BETWEEN 500 GPM AND 1000 GPM - YELLOW; FLOW RATE OF 500 GPM OR LESS - RED.
8. TRACER WIRE SHALL BE #12 AWG COPPER CLAD STEEL CORE WIRE WITH MIN. BREAK LOAD OF 450 LBS FOR OPEN CUT INSTALL RATED FOR 30 VOLTS. 45 MIL HMWPE JACKET.
9. ABOVE GROUND TEST STATION SHALL BE COBRA T3 OR APPROVED EQUAL. OUTDOOR RATED PVC CONDUIT SHALL BE INSTALLED FROM BOTTOM OF TEST STATION TO 2' BELOW FINISH GRADE. SEE DETAIL WAT-01A AND WAT-01B FOR CONNECTION DETAILS.
10. MIN 1 LB. DRIVE IN ANODE WITH MIN. 20' WIRE LEAD.
11. CONNECTORS SHALL BE DRYCONN DIRECT BURY LUG AQUA, PRO-TRACE DB, OR APPROVED EQUAL.
12. CONTRACTOR SHALL SUPPLY 1 EXTRA HYDRANT FLAG FOR EVERY 3 HYDRANTS AND 1 HYDRANT WRENCH FOR EVERY PHASE OR EVERY 5 HYDRANTS INSTALLED, WHICHEVER IS GREATER.

HYDRANT LOCATOR SUPPLIED W/ EACH HYDRANT

NOZZLE SECTION

OPERATING NUT - 1" PENTAGON

2-5" PUMPER CONNECTION (STORZ NOZZLE)

NUT CAP WITH CHAIN

2.7'

STAINLESS STEEL BRACKET TO PERMANENTLY SECURE ACCESS BOX TO GRADE FLANGE

NORMAL GROUND LINE

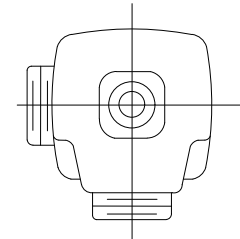

NOZZLE ARRANGEMENT TWO 5" STORZ PUMPER NOZZLES

1. ABOVE GROUND TEST STATION SHALL BE COBRA T2 (T2-R75) OR APPROVED EQUAL. OUTDOOR RATED PVC CONDUIT SHALL BE INSTALLED FROM BOTTOM OF TEST STATION TO 2' BELOW FINISH GRADE.
2. INSTALL TRACER WIRE TO MIDDLE TERMINAL
3. INSTALL GROUNDING ANODE WIRE TO BOTTOM TERMINAL
4. CONNECT JUMPER BETWEEN MIDDLE AND BOTTOM TERMINAL

NOTES:

1. 16" BREAKOFF SECTION
2. LEFT HAND OPERATING NUT (1 1/2" POINT TO FLAT)
3. PAINT BARREL SECTION RED TO GRADE
4. PLUG DRAIN HOLES ONLY IF DIRECTED BY CITY ENGINEER
5. SEE DETAIL WAT-01 FOR INSTALLATION DETAILS

NOTE: HYDRANT SHALL BE PACER MODEL WB-67-250

HYDRANT LOCATOR SUPPLIED W/ EACH HYDRANT

NOZZLE SECTION

OPERATING NUT - 1" PENTAGON

2 1/2" HOSE CONNECTION (THREAD SIZE 3.062" O.D., 7 1/2 TPI "NATIONAL STANDARD")

5" PUMPER CONNECTION (STORZ NOZZLE)

NUT CAP WITH CHAIN

2.7'

STAINLESS STEEL BRACKET TO PERMANENTLY SECURE ACCESS BOX TO GRADE FLANGE

NORMAL GROUND LINE

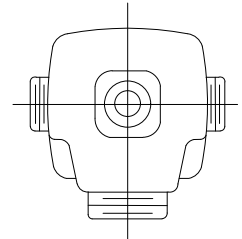

NOZZLE ARRANGEMENT TWO 2 1/2" NOZZLES PLUS 5" STORZ PUMPER NOZZLE

1. ABOVE GROUND TEST STATION SHALL BE COBRA T2 (T2-R75) OR APPROVED EQUAL. OUTDOOR RATED PVC CONDUIT SHALL BE INSTALLED FROM BOTTOM OF TEST STATION TO 2' BELOW FINISH GRADE.
2. INSTALL TRACER WIRE TO MIDDLE TERMINAL
3. INSTALL GROUNDING ANODE WIRE TO BOTTOM TERMINAL
4. CONNECT JUMPER BETWEEN MIDDLE AND BOTTOM TERMINAL

NOTES:

1. 16" BREAKOFF SECTION
2. LEFT HAND OPERATING NUT (1 1/2" POINT TO FLAT)
3. PAINT BARREL SECTION RED TO GRADE
4. PLUG DRAIN HOLES ONLY IF DIRECTED BY CITY ENGINEER
5. SEE DETAIL WAT-01 FOR INSTALLATION DETAILS

NOTE: HYDRANT SHALL BE PACER MODEL WB-67-250

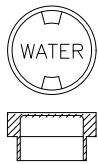

DROP LID
 TYLER NO. 6860
 MUELLER NO. H-10361
 BIBBY-STE-CROIX NO. B-5160
 EJ NO. 3669A1

GATE VALVE BOX COMPONENTS TO BE WRAPPED IN POLYWRAP AND TAPED.

7.5' MINIMUM COVER REQUIRED OVER TOP OF WATER MAIN.

ADJUST TOP TO 1/2" BELOW GRADE.
 BOX TO BE SET TO PROVIDE 12" OF ADJUSTMENT.

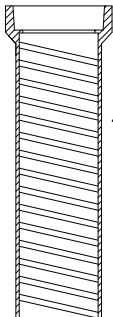

TOP
 TYLER NO. 6860 26"
 MUELLER NO. H-10361 26"
 BIBBY-STE-CROIX NO. VB502 27"
 EJ NO. 8560

GRADE

EXTENSIONS ARE REQUIRED ON ALL GATE VALVES.

EXTENSIONS SHALL BE WITHIN 1-2' OF FINISHED GRADE

ALL GATE VALVES SHALL BE MANUFACTURED IN THE US, OR CANADA

EXTENSION

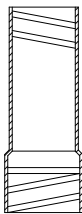

TYLER NO. 58 14"
 NO. 59 18"
 NO. 60 24"
 MUELLER NO. 58 14"
 NO. 59 20"

TYLER NO. 6860 MUELLER NO. H-10357
 BIBBY-STE-CROIX B-5001 GATE VALVE BOX, SCREW TYPE, 3 PIECE, 5 1/4" SHAFT, SIZE G BOX, 7'-6" EXTENDED, #6 ROUND BASE

ALL VALVE BOX COMPONENTS SHALL BE MANUFACTURED IN THE U.S. OR CANADA, OR AS APPROVED BY THE CITY ENGINEER.

RESILIENT WEDGE VALVE CONFORMING TO AWWA C-509-80 STANDARDS INSTALLED WITH A VALVE BOX ADAPTER TYPE II.

BIBBY-STE-CROIX

VB520 NO. 57 9"
 VB521 NO. 58 14"
 VB522 NO. 59 20"
 VB523 NO. 60 26"
 EJ NO. 8560

ADAPTOR REQUIRED ON ALL GATE VALVES (INCIDENTAL)

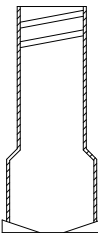

BOTTOM
 TYLER NO. 6860 65"
 MUELLER NO. H-10361 65"
 BIBBY-STE-CROIX NO. VB516 60"
 EJ NO. 8560

GATE VALVE ADAPTOR 1/4" STEEL WITH PROTECTIVE COATING

1/2" RUBBER GASKET INSTALLED BETWEEN THE GATE VALVE AND GATE VALVE ADAPTOR

COPPER TRACER WIRE INSTALL ON ALL PVC WATER MAIN

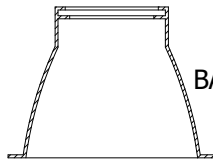

BASE

8" CONCRETE BLOCK

MEGALUGS(TYP)

NOTE:

1. ALL WATERMAIN BOLTS ARE TO BE CORE-BLUE OR AN APPROVED EQUAL.
2. CONTRACTOR MUST SUPPLY 1 GATE VALVE KEY PER EVERY 10 VALVES OR 1 PER PHASE, WHICHEVER IS GREATER.

NOTE: ALL BUTTERFLY VALVES SHALL BE INDIVIDUALLY HYDROSTATICALLY TESTED AGAINST BOTH SIDES OF VALVE

COR-BLUE OR STAINLESS STEEL BOLTS REQUIRED FOR ALL MECHANICAL FITTINGS.



DROP LID
 TYLER NO. 6850 OR 6860
 MUELLER NO. H-10361
 BIBBY-STE-CROIX NO. B-5160

PROVIDE POLYWRAP AND TAPE AROUND ALL DIP WATERMAIN AND VALVE BOX.

7.5' MINIMUM COVER REQUIRED OVER TOP OF WATER MAIN.

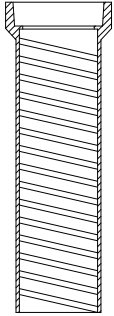

TOP
 TYLER NO. 6850 26"
 MUELLER NO. H-10361 26"
 BIBBY-STE-CROIX NO. VB502 27"

RESTRAIN TEE AND VALVE WITH MEGALUG (OR EQUAL) THRUST RESTRAINTS.

ALL VALVES AND VALVE BOXES SHALL BE MADE IN THE US OR CANANDA.

EXTENSION SHALL BE WITHIN 1-2' OF FINISHED GRADE

ALL VALVE BOLTS TO BE STAINLESS STEEL.

ADJUST TOP TO 1/2" BELOW GRADE. BOX TO BE SET TO PROVIDE 12" OF ADJUSTMENT.

EXTENSION
 TYLER NO. 58 14"
 NO. 59 18"
 NO. 60 24"
 MUELLER NO. 58 14"
 NO. 59 20"
 BIBBY-STE-CROIX
 VB520 NO. 57 9"
 VB521 NO. 58 14"
 VB522 NO. 59 20"
 VB523 NO. 60 26"

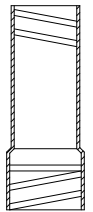

TYLER NO. 6850
 MUELLER NO. H-10357
 BIBBY-STE-CROIX B-5001
 GATE VALVE BOX, SCREW TYPE, 3 PIECE, 5 1/4" SHAFT, SIZE G BOX, 7'-6" EXTENDED.

EXTENSIONS REQUIRED ON ALL BUTTERFLY VALVES
 EXTENSION SHALL BE WITHIN 1-2' OF FINISHED GRADE

ADAPTOR REQUIRED ON ALL BUTTERFLY VALVES

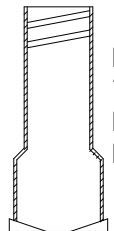

BOTTOM
 TYLER NO. 6850 65"
 MUELLER NO. H-10361 65"
 BIBBY-STE-CROIX NO. VB516 60"

BUTTERFLY VALVE (>12") DEZURIK OR APPROVED EQUAL

BUTTERFLY VALVE ADAPTER

CONTRACTOR IS TO SUPPLY THE CITY WITH 1 GATE VALVE KEY PER EVERY 10 VALVES OR PHASE, WHICHEVER IS GREATER.

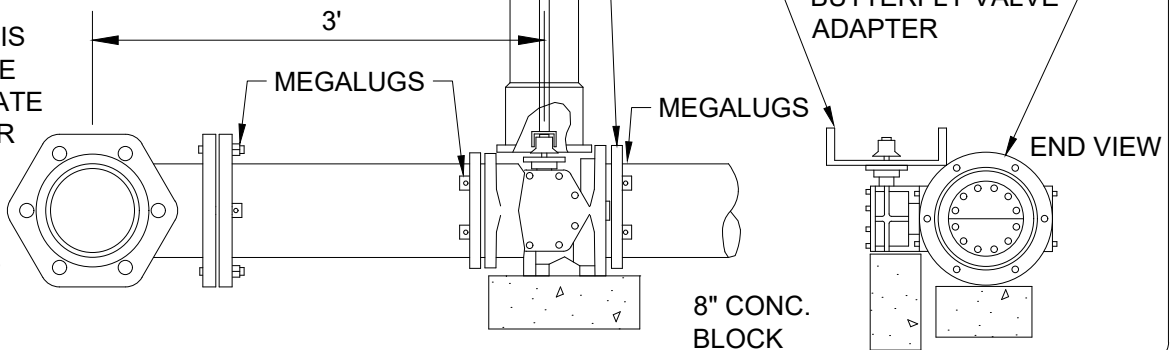

ALL FITTINGS SHALL BE POLYWRAPPED AND TAPED

POWERSEAL, ROMAC, OR APPROVED EQUAL FUSION BONDED EPOXY COATED DUCTILE IRON OR STAINLESS STEEL TAPPING SLEEVE.

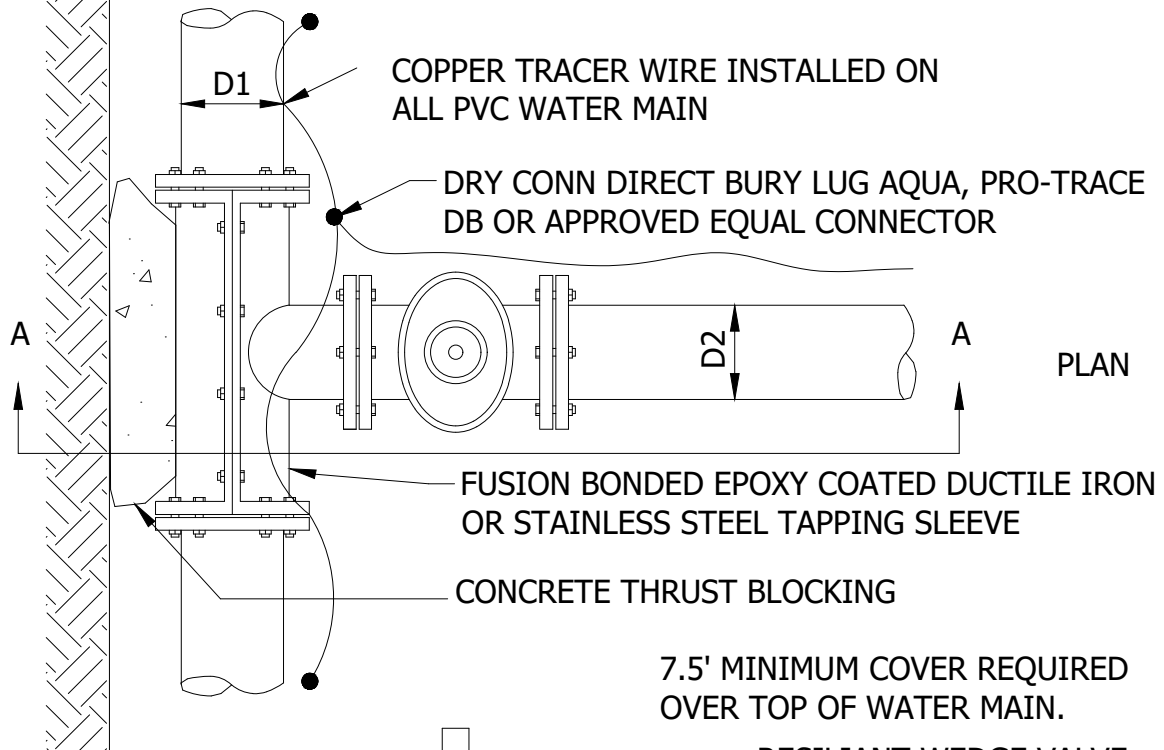

NOTE: ALL WATERMAIN BOLTS SHALL BE CORE-BLUE OR AN APPROVED EQUAL

NOTES:

1. SHAPE OF BACK OF BUTTRESS MAY VARY AS LONG AS POURED AGAINST FIRM UNDISTURBED EARTH.
2. DIMENSION C1,C2,C3 SHOULD BE LARGE ENOUGH TO MAKE ANGLE θ EQUAL TO OR LARGER THAN 45° .
3. DIMENSION A1,A2,A3 SHOULD BE AS LARGE AS POSSIBLE WITHOUT INTERFERING WITH MJ BOLTS.
4. $\theta = 45^\circ$ MINIMUM.
5. PLACE POLYETHYLENE BETWEEN CONCRETE & PIPE.
6. MEGALUGS SHALL BE INSTALLED ON ALL FITTINGS.
7. ALL WATER MAIN BOLTS SHALL BE COR-BLUE OR APPROVED EQUAL.

BUTTRESS DIMENSIONS						
PIPE SIZE	22 1/2° BEND		45° BEND		90° BEND	
	B ₁	D ₁	B ₂	D ₂	B ₃	D ₃
6"	1'-5"	1'-5"	1'-5"	1'-5"	2'-1"	1'-6"
8"	1'-5"	1'-5"	2'-1"	1'-6"	2'-8"	2'-0"
12"	1'-10"	1'-10"	3'-4"	2'-0"	4'-9"	2'-6"
16"	3'-0"	2'-0"	3'-10"	3'-0"	6'-2"	3'-6"
20"	3'-6"	2'-8"	5'-6"	3'-4"	8'-4"	4'-0"
24"	4'-4"	3'-0"	6'-10"	3'-10"	9'-8"	5'-0"
30"	-	-	9'-3"	6'-0"	17'-0"	6'-0"

ALL DUCTILE IRON FITTINGS TO BE FUSION BONDED EPOXY COATED.
 ALL DUCTILE IRON PIPE AND FITTINGS TO BE WRAPPED IN POLY AND TAPED.
 ALL DUCTILE IRON PIPES AND FITTINGS TO BE MANUFACTURED IN US OR CANADA, OR AS APPROVED BY THE CITY ENGINEER.

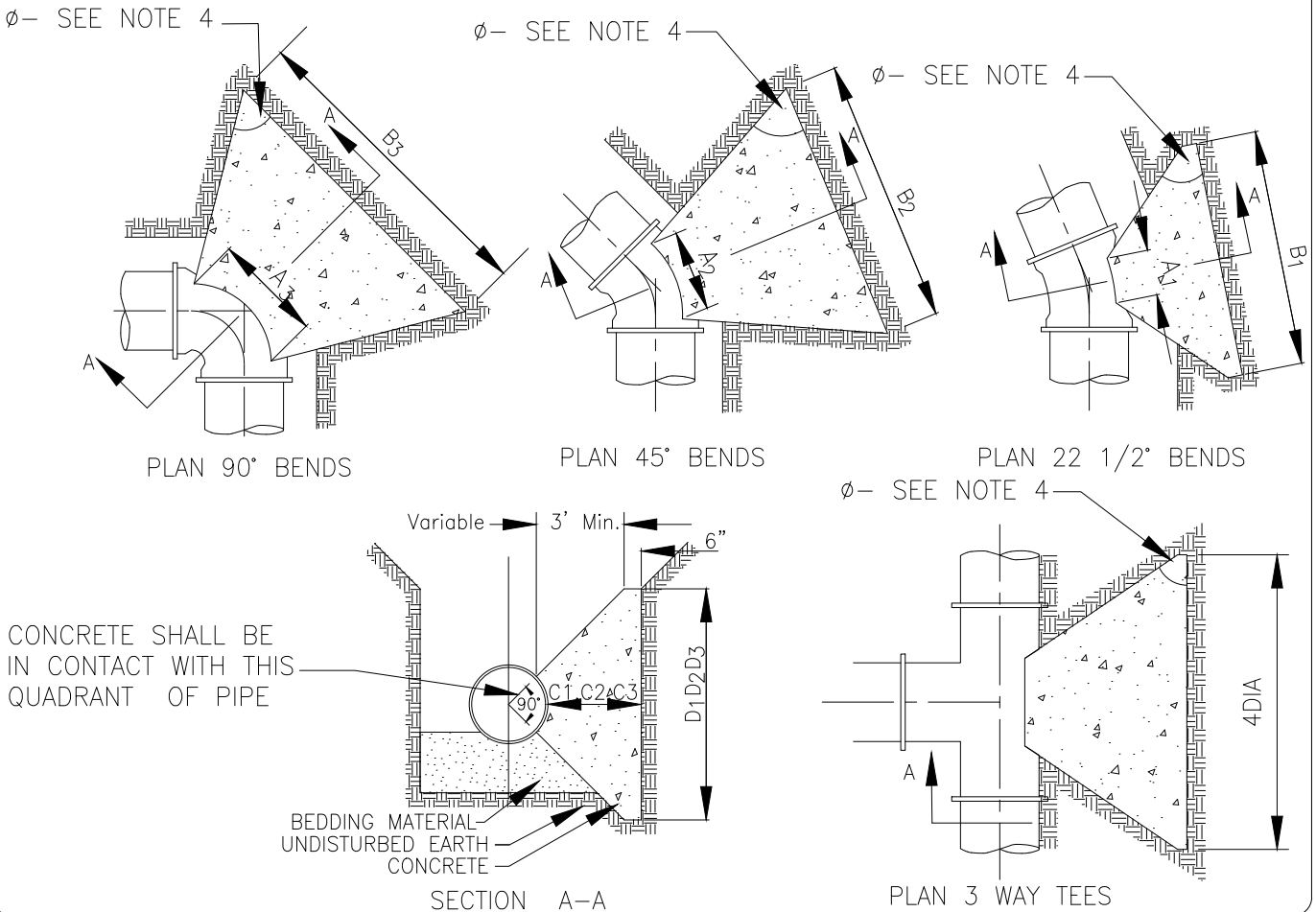

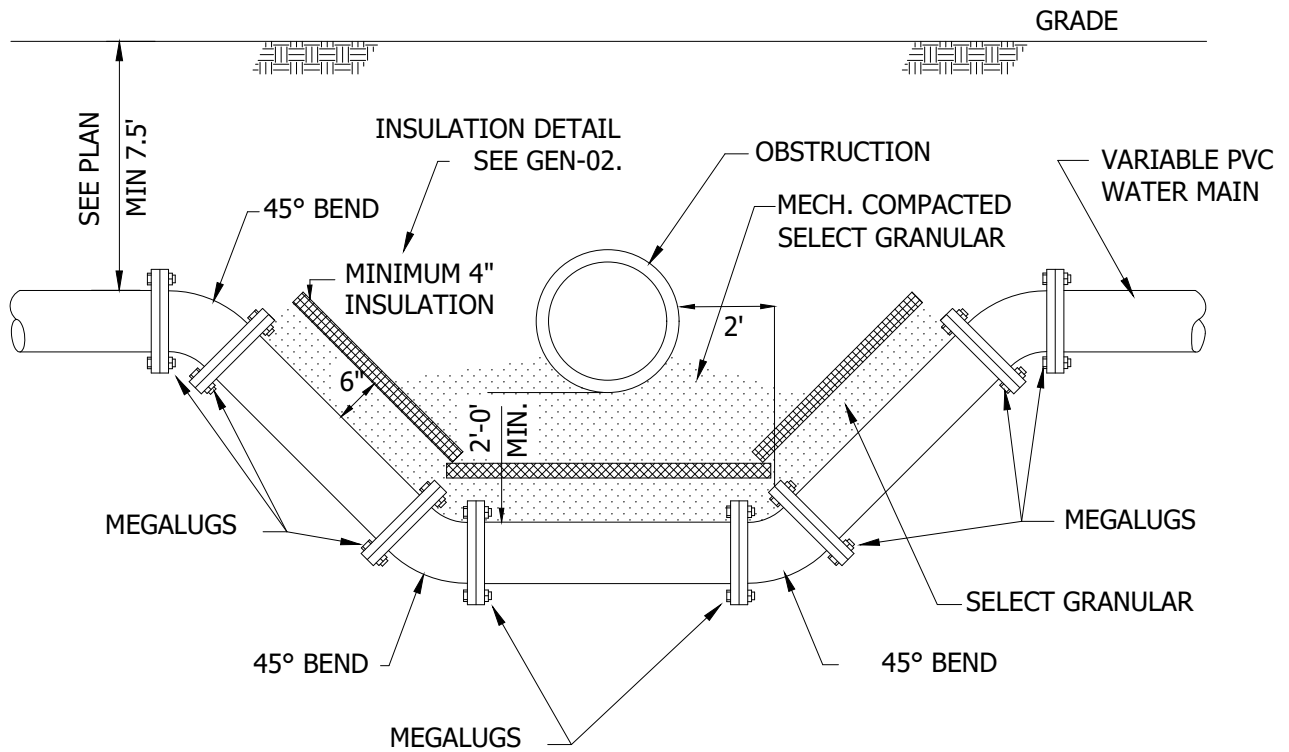

NOTE:

1. ALL FITTINGS SHALL BE FUSION BONDED EPOXY COATED DUCTILE IRON TO MEET OR EXCEED ANSI/AWWA C550 AND C116/A21.116 REQUIREMENTS.
2. MEGALUGS WILL NOT BE ALLOWED ON ANY CIP WATER MAIN.
3. SELECT GRANULAR WILL BE REQUIRED BETWEEN INSULATION, WATER MAIN, AND OBSTRUCTION.
4. ALL BENDS SHALL HAVE MEGALUGS WITH BLOCKING IN ACCORDANCE WITH STANDARD PLATE WAT-04.
5. COPPER TRACER WIRE SHALL BE USED ON PVC WATER MAIN
6. ALL WATER MAIN BOLTS SHALL BE CORE-BLUE OR APPROVED EQUAL.
7. ALL DIP FITTINGS SHALL BE POLY WRAPPED AND TAPED.
8. ALTERNATIVE OFFSET STRATEGIES MAY BE ALLOWED AT THE DISCRETION OF THE ENGINEER.
9. INSULATION AND BACKFILL REQUIREMENTS SHALL APPLY TO ALL CROSSINGS WITH MINIMAL SEPARATION. IF LESS THAN 2' OF SEPARATION IS PRESENT, ADDITIONAL INSULATION WILL BE REQUIRED AT THE DISCRETION OF THE CITY ENGINEER.

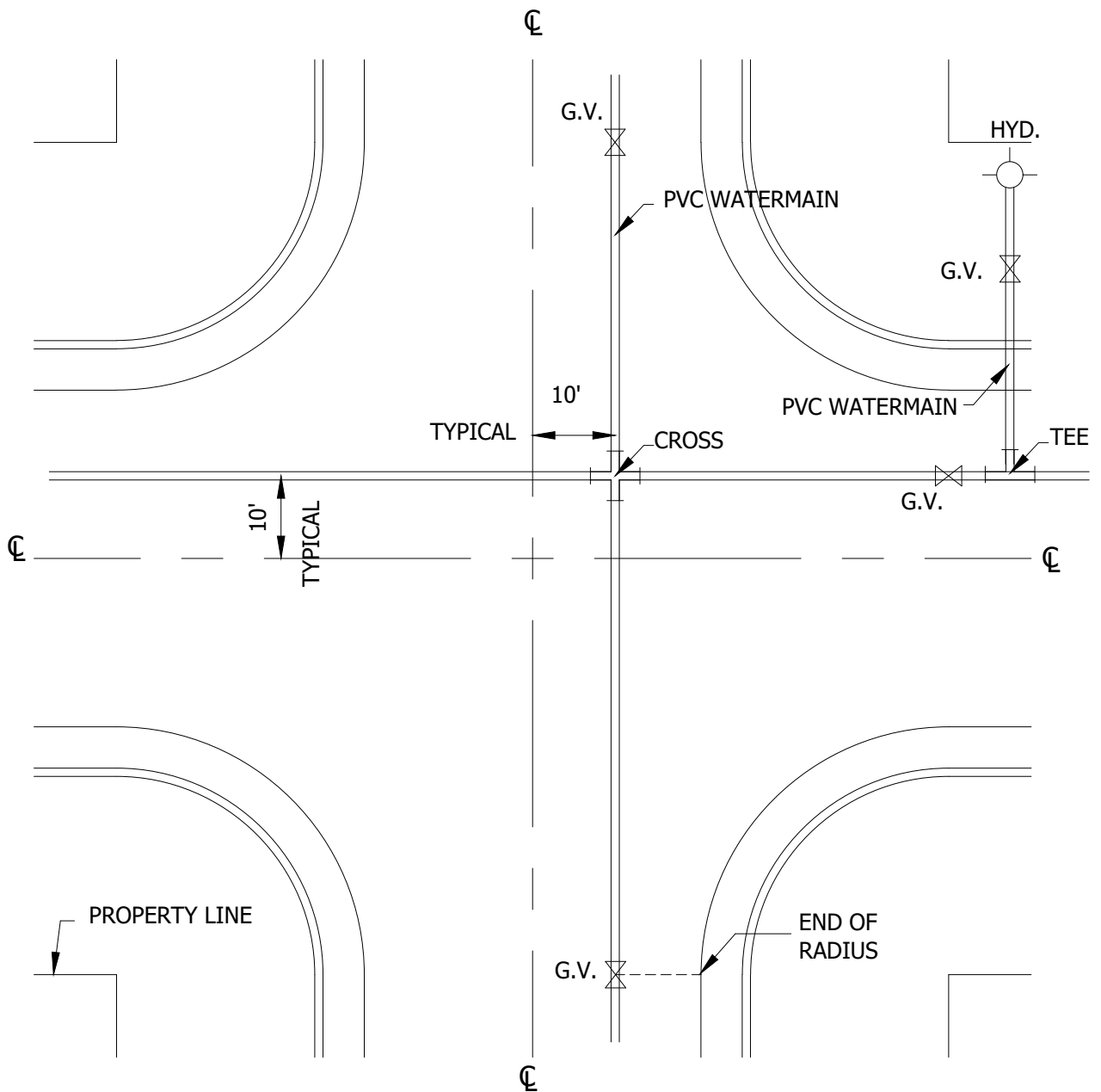

NOTE:

1. SEE DETAIL PLATE WAT-01 FOR TYPICAL HYDRANT AND GATE VALVE LAYOUT.
2. SEE DETAIL PLATE SER-01 FOR TYPICAL WATER SERVICE CONNECTION.
3. ALL WATERMAIN SHALL BE PLACED NORTH AND EAST OF THE CENTER LINE OF ROAD.
4. ALL DUCTILE IRON WATERMAIN FITTINGS SHALL BE FUSION BONDED EPOXY COATED, POLYWRAPPED, AND TAPED.
5. ALL PVC WATERMAIN SHALL HAVE A COPPER TRACER WIRE.
6. TRACER WIRE CONNECTOR SHALL BE DRY CONN DIRECT BURY LUG AQUAL, PRO-TRACE DB OR APPROVED EQUAL.
7. ALL VALVES TO HAVE 3' OF PIPE MINIMUM BETWEEN TEES, CROSSES, & HYDRANTS.

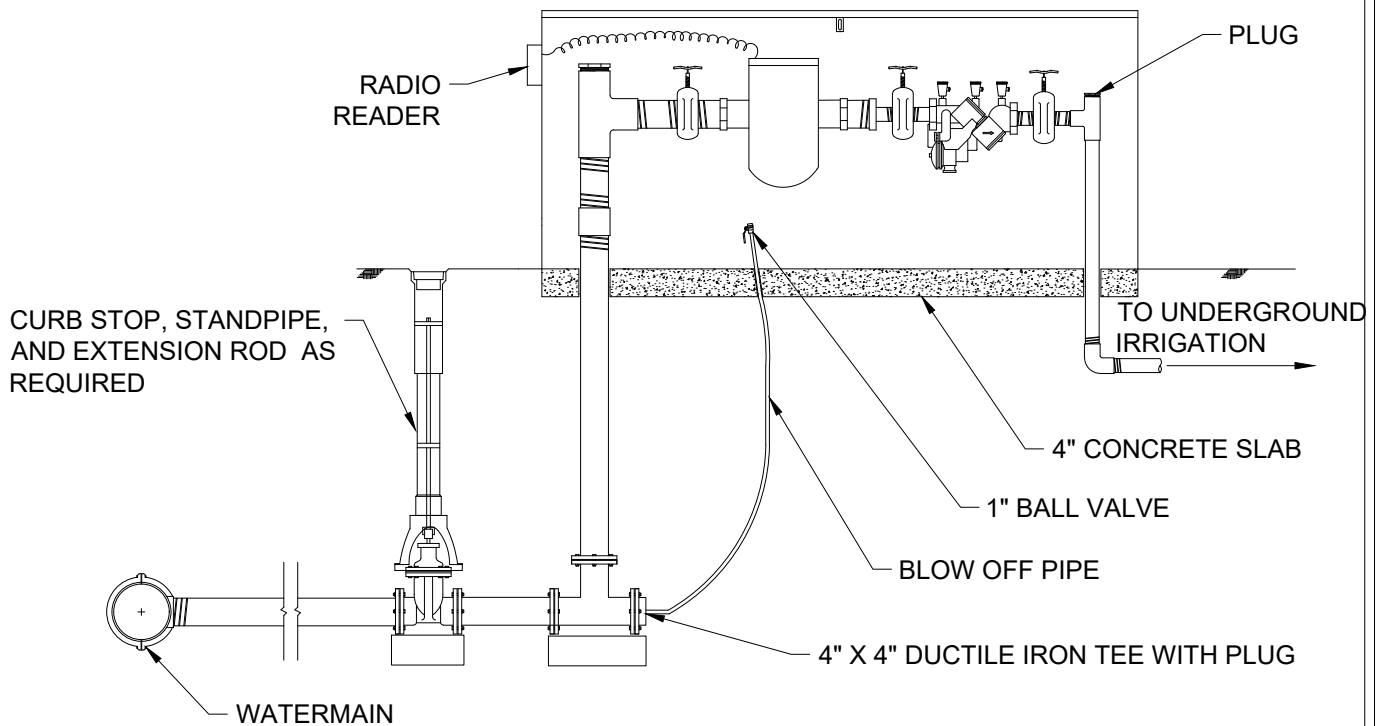

NOTE:

1. TO WINTERIZE, REMOVE AND DRAIN METER, SIPHON WATER FROM FEED LINE, BLOW OUT IRRIGATION LINES AND REINSTALL METER.
2. SECURITY BOX MUST BE MAINTENANCE FREE VANDELPROOF ENCLOSURE, WITH HINGED TOP.
3. IF THE BOX IS LOCKED, MOUNT A LOCKBOX ON THE SIDE WITH A KEY TO THE BOX WITH THE COMBINATION OR THE COMBINATION IF IT IS JUST A COMBINATION LOCK. THIS REQUIRED IN CASE THE CITY NEEDS TO ACCESS TO THE BOX FOR METER READINGS OR LEAKS.

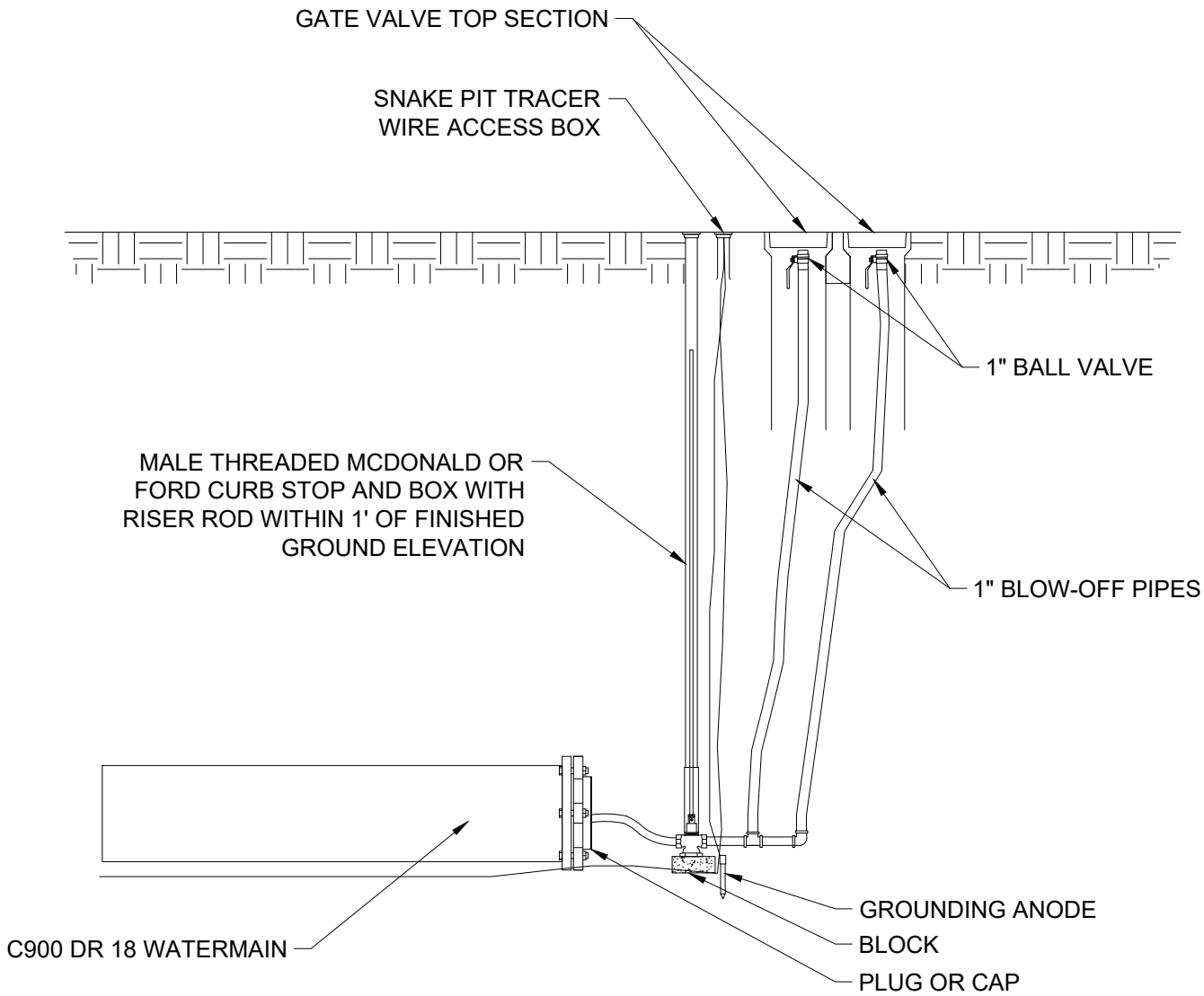

PLAN

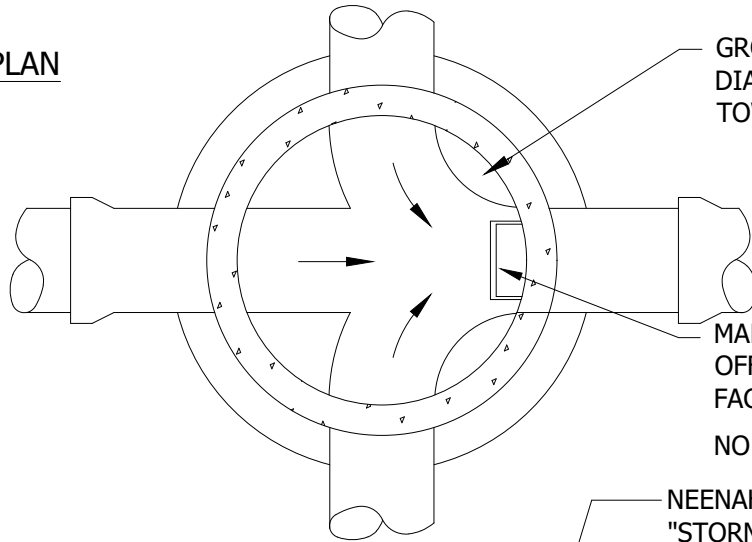

GROUT BOTTOM OF MANHOLE TO 1/2 DIAMETER AT PIPE AND SLOPE GROUT 2" TOWARD INVERT.

CASTING	A	B
R1642	27"	7"

MANHOLE STEPS SHALL BE PLACED SO THAT OFFSET VERTICAL PORTION OF CONE IS FACING DOWNSTREAM.

NO BLOCK STRUCTURES ARE ALLOWED.

SECTION

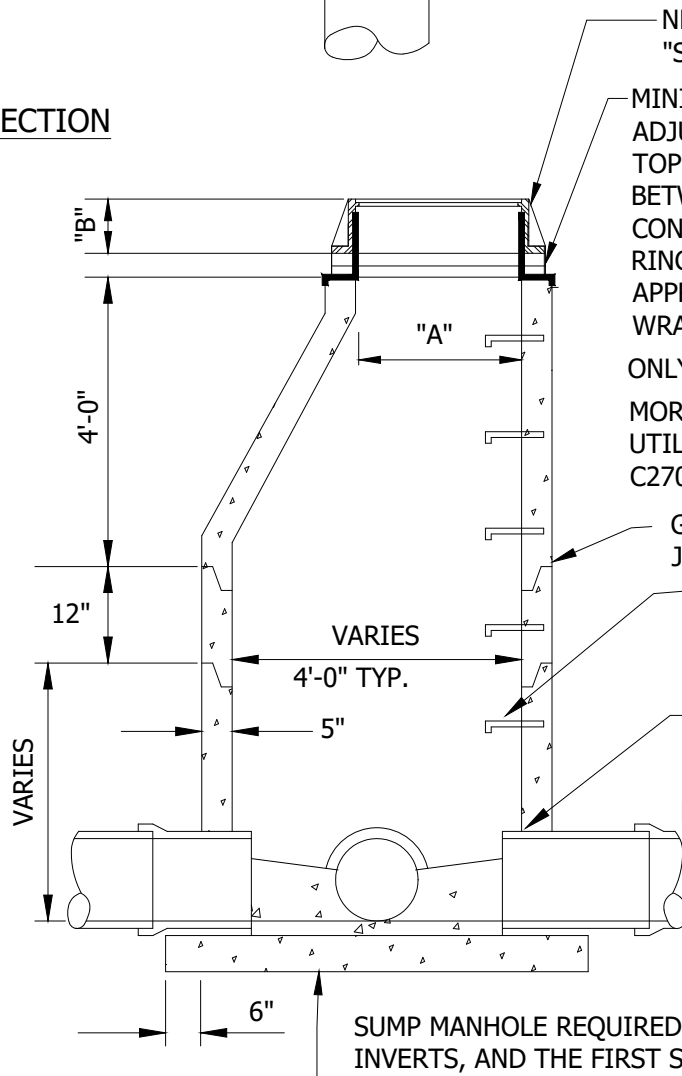

NEENAH FRAME AND COVER OR EQUAL, LETTERED, "STORM SEWER", WITH 2 CONCEALED PICK HOLES.

MINIMUM OF 4" AND MAXIMUM OF 12" OF CONCRETE ADJUSTMENT RINGS. 2" RINGS MUST BE USED FOR THE TOP TWO RINGS. A FULL BED OF MORTAR MUST BE BETWEEN EACH RING. 1 RING WITH MORTAR = 0.2'. CONCRETE COLLAR REQUIRED AROUND ALL ADJUSTING RINGS. INSTALL INTERIOR I & I BARRIER EULL'S OR APPROVED EQUAL. EXTERNAL INFI-SHIELD OR GATOR WRAP ALLOWED FOR GREEN SPACE STRUCTURES. ONLY PLASTIC SHIMS SHALL BE ALLOWED IF NEEDED. MORTAR SHALL BE AIR ENTRAINED UNDERGROUND UTILITY MORTAR WHICH MEETS OR EXCEEDS ASTM C270 AND ASTM C387.

GATOR WRAP REQUIRED ON TOP JOINT. ALL OTHER JOINTS TO BE WRAPPED AS DIRECTED BY ENGINEER

MANHOLE STEPS, COPOLYMER POLYPROPYLENE PLASTIC WITH 1/2" GRADE 60 STEEL REINFORCEMENT OR EQUAL. 16" ON CENTER

PIPE SHALL BE CUT OFF 2" FROM INSIDE FACE OF WALL. DOGHOUSES MUST BE GROUTED FROM BOTH THE INSIDE AND OUTSIDE.

NOTE:

KOR-N-SEAL MANHOLE OR EQUAL CONSIDERED ACCEPTABLE ALTERNATE.

ALL JOINTS IN MANHOLE TO HAVE "O" RING RUBBER GASKETS.

SUMP MANHOLE REQUIRED WHEN THERE IS A 1.5' OR GREATER DROP BETWEEN INVERTS, AND THE FIRST STRUCTURE UPSTREAM FROM PIPE OUTLET.

MINIMUM SLAB THICKNESS IS 6" FOR STRUCTURES 14' IN DEPTH OR LESS. INCREASE THICKNESS 1" FOR EVERY 4' OF DEPTH GREATER THAN 14', AND REINFORCE WITH 6" X 6" 10/10 MESH.

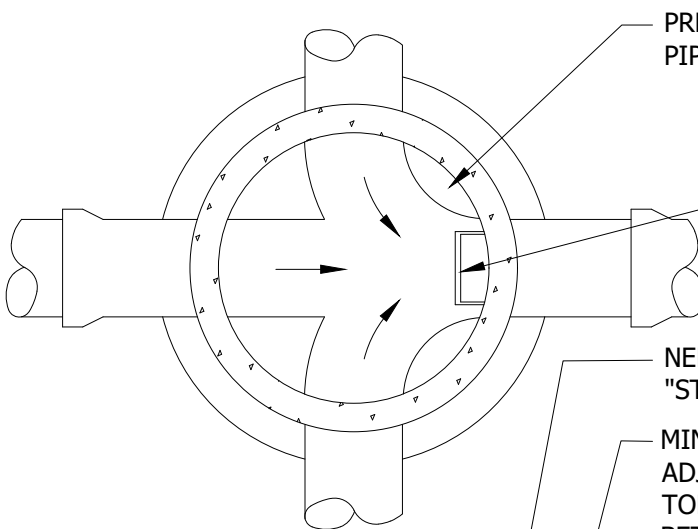

PRECAST INVERT SHOULD BE 1/2" DIAMETER OF PIPE AND BENCHES SLOPED 2" TOWARD INVERT.

CASTING	A	B
R1642	27"	7"

MANHOLE STEPS SHALL BE PLACED SO THAT OFFSET VERTICAL PORTION OF CONE IS FACING DOWNSTREAM.

NO BLOCK STRUCTURES ARE ALLOWED.

PLAN

FOR 6' DIAMETER MANHOLE, AN 8" PRECAST SLAB IS REQUIRED.

NEENAH FRAME AND COVER OR EQUAL LETTERED, "STORM SEWER", WITH 2 CONCEALED PICK HOLES.

MINIMUM OF 4" AND MAXIMUM OF 12" OF CONCRETE ADJUSTMENT RINGS. 2" RINGS MUST BE USED FOR THE TOP TWO RINGS. A FULL BED OF MORTAR MUST BE BETWEEN EACH RING. 1 RING WITH MORTAR = 0.2'. INSTALL INSIDE I&I BARRIER EULL'S OR APPROVED EQUAL. EXTERNAL INFI-SHIELD OR GATOR WRAP ALLOWED FOR GREEN SPACE STRUCTURES.

ONLY PLASTIC SHIMS SHALL BE ALLOWED IF NEEDED.

MORTAR SHALL BE AIR ENTRAINED UNDERGROUND UTILITY MORTAR WHICH MEETS OR EXCEEDS ASTM C270 AND ASTM C387.

6" PRECAST REINFORCED CONCRETE MANHOLE SLAB WITH #4 BARS AT 5" O.C. EACH WAY AND 2-#4 BARS AT ALL SIDES OF OPENING.

TOP OF BARREL SECTION BELOW TOP SLAB TO HAVE FLAT TOP EDGE SEALED WITH 2 BEADS OF RAMNEK OR APPROVED EQUAL. EXTERIOR TO HAVE NEOPRENE WRAP (INFI-SHIELD OR APPROVED EQUAL)

MANHOLE STEPS, COPOLYMER POLYPROPYLENE PLASTIC, WITH 1/2 " GRADE 60 STEEL REINFORCEMENT OR APPROVED EQUAL. 16" ON CENTER

ALL JOINTS IN MANHOLE TO HAVE "O" RING RUBBER GASKETS.

PIPE SHALL BE CUT OFF 2" FROM INSIDE FACE OF WALL.

DOGHOUSES MUST BE GROUTED BOTH INSIDE AND OUTSIDE.

MINIMUM SLAB THICKNESS IS 6" FOR STRUCTURE 14' IN DEPTH OR LESS. INCREASE THICKNESS 1" FOR EVERY 4' OF DEPTH GREATER THAN 14', AND REINFORCE WITH 6" X 6" 10/10 MESH.

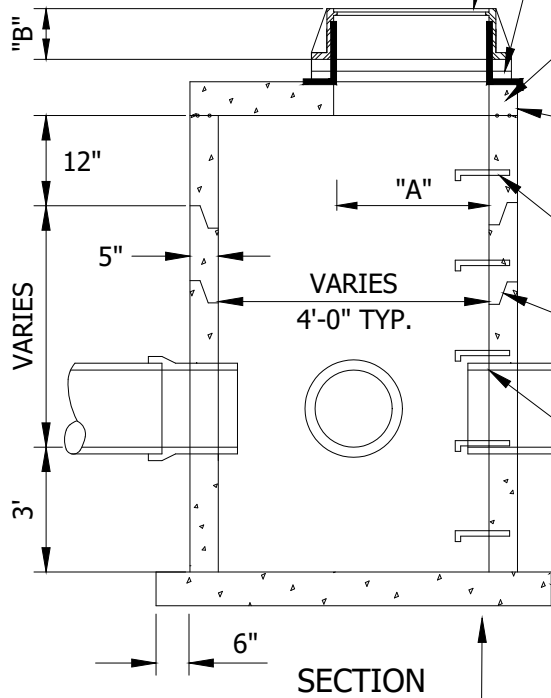

SECTION

MUD SUMP SUCH THAT A BASIN IS CREATED FOR MAINTENANCE.

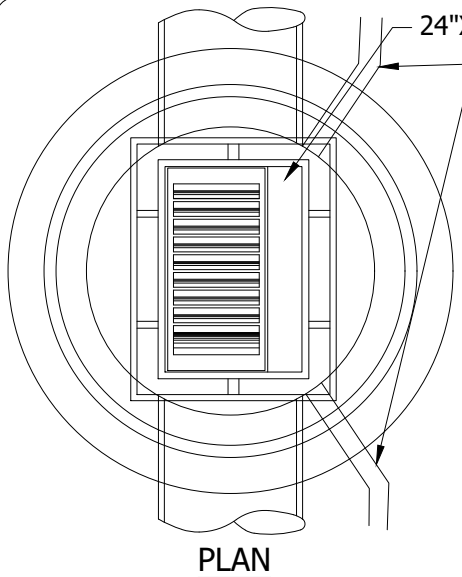

PLAN

24"X36" SLAB OPENING FOR NEENAH R3067V OR EQUAL

TYPICAL DRAINTILE CONNECTIONS. NO BENDS GREATER THAN 45° SHALL BE ALLOWED.

DIMENSION FROM BACK OF CURB TO CENTER OF PIPE. 4' DIA. MH - 9" IN FROM BACK OF CURB 5' DIA. MH - 3" IN FROM BACK OF CURB 6' DIA. MH - 3" BEHIND BACK OF CURB 7' DIA. MH - 9" BEHIND BACK OF CURB 8' DIA. MH - 15" BEHIND BACK OF CURB

NOTES:

1. CATCHBASIN FRAME & COVER NEENAH R-3067-VB BIDIRECTIONAL CASTING AT LOW POINTS AND NEENAH R-3067-V UNIDIRECTIONAL CASTING AT OTHER LOCATIONS. NEENAH R-3290-7000 ("DUMP NO WASTE DRAINS TO FRESH WATER" WITH IMAGE OF FISH AND DUCK) OR APPROVED EQUAL CURB BOX.
2. NO BLOCK STRUCTURES ARE ALLOWED.
3. ONLY PLASTIC SHIMS SHALL BE ALLOWED IF NEEDED.
4. MORTAR SHALL BE AIR-ENTRAINED UNDERGROUND UTILITY MORTAR WHICH MEETS OR EXCEEDS ASTM C270 AND ASTM C387.
5. DOGHOUSES SHALL BE GROUTED ON BOTH THE OUTSIDE AND THE INSIDE.

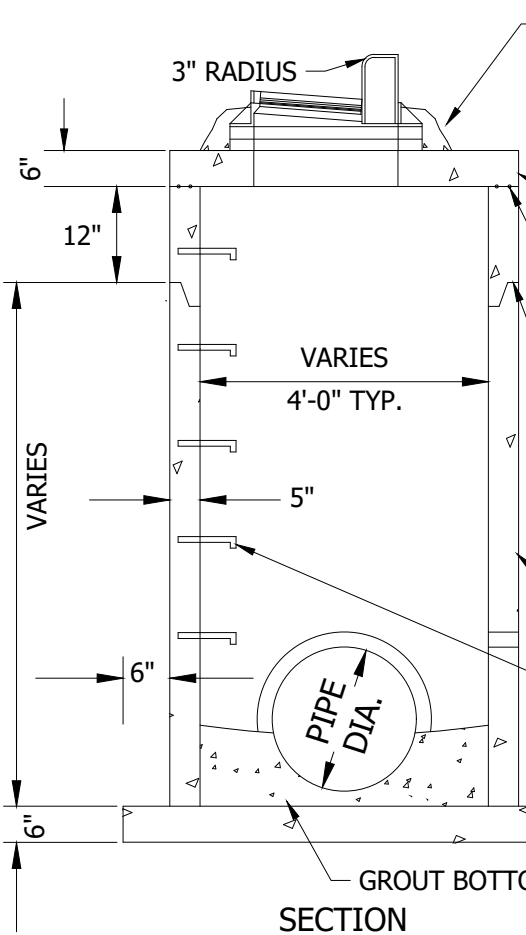

SECTION

MINIMUM OF 4" AND MAXIMUM OF 12" OF CONCRETE ADJUSTMENT RINGS. 2" RINGS MUST BE USED FOR THE TOP TWO RINGS. A FULL BED OF MORTAR MUST BE BETWEEN EACH RING. 1 RING WITH MORTAR = 0.2'; MAX. HORIZONTAL OFFSET=0.25'. INSTALL EXTERNAL INFI-SHIELD OR APPROVED EQUAL.

6" PRECAST REINFORCED CONCRETE SLAB

TOP SLAB TO BE RESET OR OTHER ADJUSTMENTS MAY BE REQUIRED FOR POOR ALIGNMENT AT THE CITY ENGINEER'S DIRECTION

TOP OF BARREL SECTION UNDER TOP SLAB TO HAVE FLAT TOP EDGE SEALED WITH 2 BEADS OF RAMNEK OR APPROVED EQUAL. EXTERIOR TO HAVE GATOR WRAP OR APPROVED EQUAL.

ALL JOINTS IN MANHOLE TO HAVE "O" RING RUBBER GASKETS

PRECAST CONCRETE SECTION

MANHOLE STEPS, COPOLYMER POLYPROPYLENE PLASTIC, WITH 1/2 " GRADE 60 STEEL REINFORCEMENT OR APPROVED EQUAL SPACED 16" ON CENTER

MINIMUM SLAB THICKNESS, 6" FOR STRUCTURES 14' IN DEPTH. INCREASE THICKNESS 1" FOR EACH 4' OF DEPTH GREATER THAN 14' AND REINFORCE WITH 6"X6" 10/10 MESH.

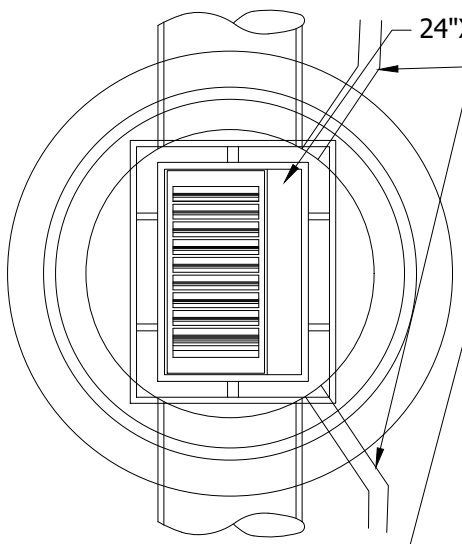

PLAN

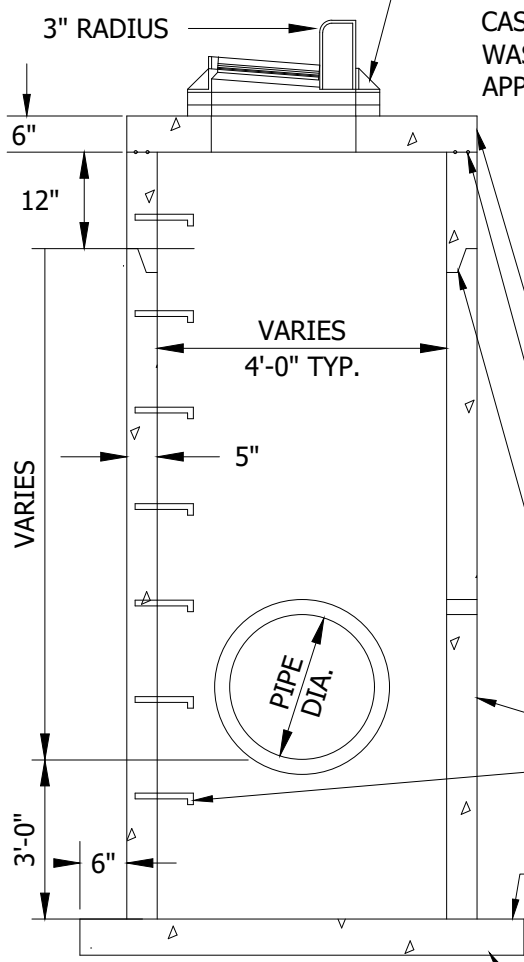

SECTION

24"X36" SLAB OPENING FOR NEENAH R3067V OR EQUAL
 TYPICAL DRAINTILE CONNECTIONS. NO BENDS GREATER THAN 45° SHALL BE ALLOWED.
 DIMENSION FROM BACK OF CURB TO CENTER OF PIPE. 4' DIA. MH - 9" IN FROM BACK OF CURB 5' DIA. MH - 3" IN FROM BACK OF CURB 6' DIA. MH - 3" BEHIND BACK OF CURB 7' DIA. MH - 9" BEHIND BACK OF CURB 8' DIA. MH - 15" BEHIND BACK OF CURB

MINIMUM OF 4" AND MAXIMUM OF 12" OF CONCRETE ADJUSTMENT RINGS. 2" RINGS MUST BE USED FOR THE TOP TWO RINGS. A FULL BED OF MORTAR MUST BE BETWEEN EACH RING. 1 RING WITH MORTAR = 0.2'; MAX. HORIZONTAL OFFSET=0.25'. INSTALL EXTERNAL INFI-SHIELD OR APPROVED EQUAL

NOTES:

1. SUMP MANHOLE REQUIRED WHEN THERE IS A 1.5' OR GREATER DROP BETWEEN INVERTS, AND THE FIRST STRUCTURE UPSTREAM FROM PIPE OUTLET.
2. CATCHBASIN FRAME & COVER NEENAH R-3067-VB BIDIRECTIONAL CASTING AT LOW POINTS AND NEENAH R-3067-V UNIDIRECTIONAL CASTING AT OTHER LOCATIONS. NEENAH R-3290-7000 ("DUMP NO WASTE DRAINS TO FRESH WATER" WITH IMAGE OF FISH AND DUCK) OR APPROVED EQUAL CURB BOX.
3. NO BLOCK STRUCTURES ARE ALLOWED.
4. ONLY PLASTIC SHIMS SHALL BE ALLOWED IF NEEDED.
5. MORTAR SHALL BE AIR-ENTRAINED UNDERGROUND UTILITY MORTAR WHICH MEETS OR EXCEEDS ASTM C270 AND ASTM C387.
6. DOGHOUSES SHALL BE GROUTED ON BOTH THE OUTSIDE AND THE INSIDE.
7. NO TEES WILL BE ALLOWED FOR DRAINTILE FITTINGS.

6" PRECAST REINFORCED CONCRETE SLAB. TOP SLAB TO BE RESET OR OTHER ADJUSTMENTS MAY BE REQUIRED FOR POOR ALIGNMENT AT CITY ENGINEER'S DIRECTION

TOP OF BARREL SECTION UNDER TOP SLAB TO HAVE FLAT TOP EDGE SEALED WITH 2 BEADS OF RAMNEK OR APPROVED EQUAL. EXTERIOR TO HAVE GATOR WRAP OR APPROVED EQUAL.

ALL JOINTS IN MANHOLE TO HAVE "O" RING RUBBER GASKETS

PRECAST CONCRETE SECTION

MANHOLE STEPS, COPOLYMER POLYPROPYLENE PLASTIC, WITH 1/2 " GRADE 60 STEEL REINFORCEMENT OR APPROVED EQUAL SPACED 16" ON CENTER

MINIMUM SLAB THICKNESS, 6" FOR STRUCTURES 14' IN DEPTH. INCREASE THICKNESS 1" FOR EACH 4' OF DEPTH GREATER THAN 14' AND REINFORCE WITH 6"X6" 10/10 MESH

MUD SUMP SUCH THAT A BASIN IS CREATED FOR MAINTENANCE

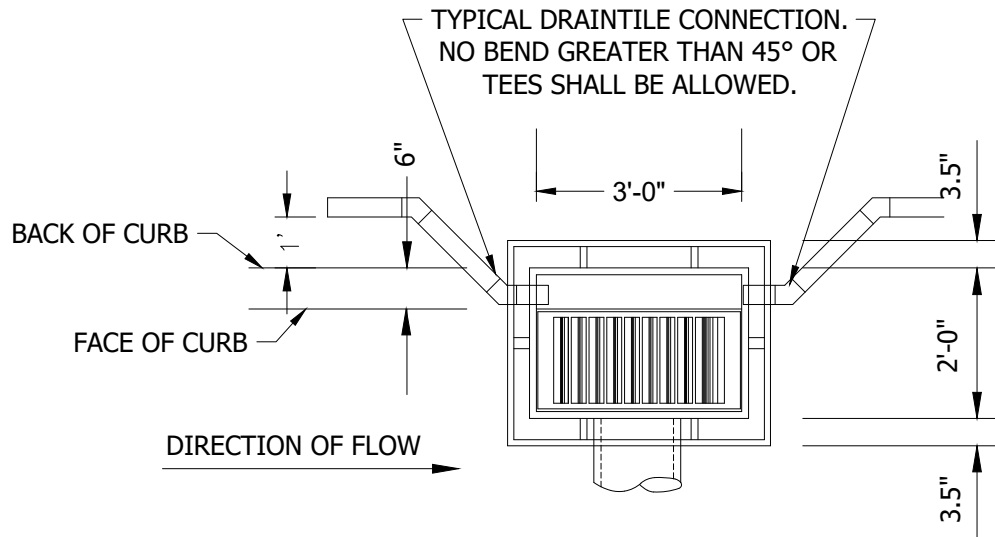

PLAN

CATCHBASIN CASTING NEENAH R-3067-V (OR R-3501) OR APPROVED EQUAL WITH NEENAH R-3290-7000 ("DUMP NO WASTE DRAINS TO FRESH WATER" WITH IMAGE OF FISH AND DUCK) OR APPROVED EQUAL CURB BOX.

NO BLOCK STRUCTURES ARE ALLOWED.

MINIMUM OF 4" AND MAXIMUM OF 12" OF CONCRETE ADJUSTMENT RINGS. 2" RINGS MUST BE USED FOR THE TOP TWO RINGS. A FULL BED OF MORTAR MUST BE BETWEEN EACH RING. 1 RING WITH MORTAR = 0.2'. CONCRETE COLLAR REQUIRED AROUND ALL ADJUSTING RINGS. MAXIMUM HORIZONTAL OFFSET=0.25' (3"). INSTALL EXTERNAL INFI-SHIELD OR APPROVED EQUAL.

ONLY PLASTIC SHIMS SHALL BE ALLOWED IF NEEDED.

MORTAR SHALL BE AIR ENTRAINED UNDERGROUND UTILITY MORTAR WHICH MEETS OR EXCEEDS ASTM C270 AND ASTM C387.

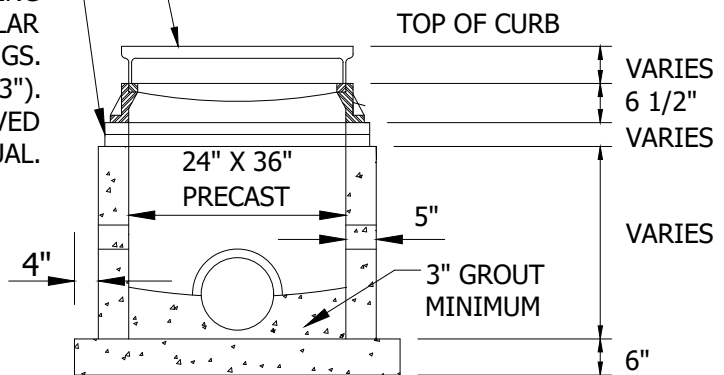

SECTION

DOGHOUSES SHALL BE GROUTED ON BOTH THE INSIDE AND OUTSIDE.

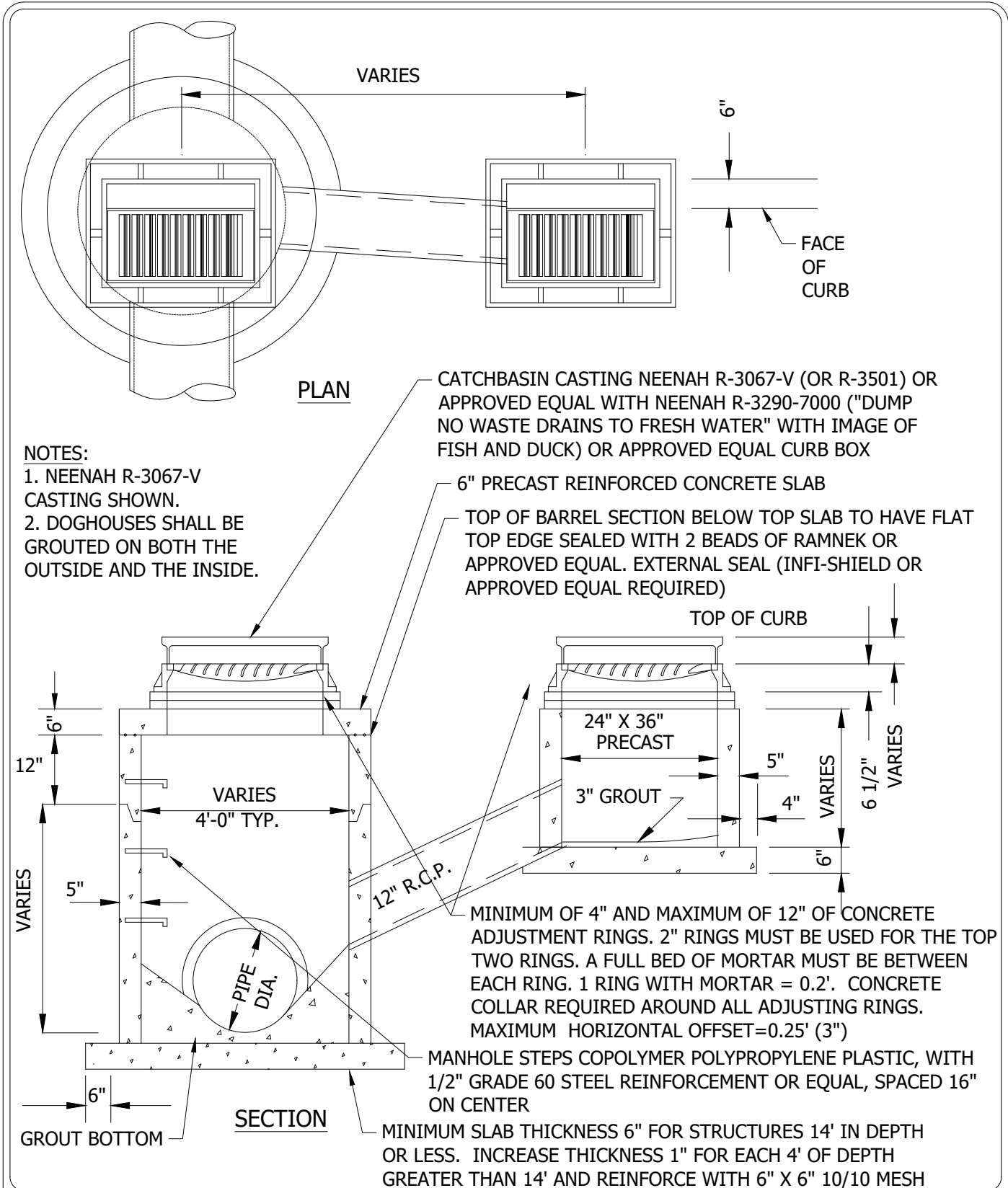

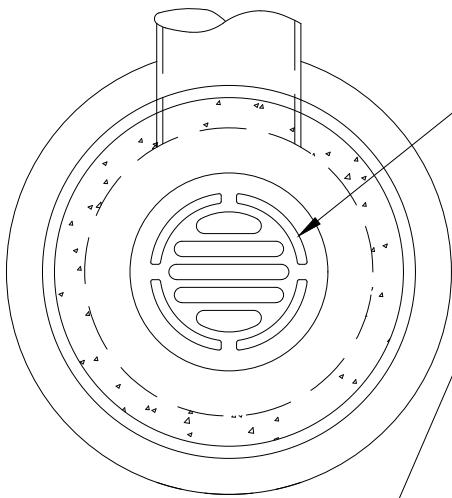

PLAN

NEENAH R-4342 CASTING OR EQUAL
NO BLOCK STRUCTURES ARE ALLOWED.

MINIMUM OF 4" AND MAXIMUM OF 12" OF CONCRETE ADJUSTMENT RINGS. 2" RINGS MUST BE USED FOR THE TOP TWO RINGS. A FULL BED OF MORTAR MUST BE BETWEEN EACH RING. INSTALL EXTERIOR I & I OR APPROVED EQUAL. 1 RING WITH MORTAR=0.2'; MAX HORIZONTAL OFFSET= .25'(3").

ONLY PLASTIC SHIMS SHALL BE ALLOWED IF NEEDED. MORTAR SHALL BE AIR ENTRAINED UNDERGROUND UTILITY MORTAR WHICH MEETS OR EXCEEDS ASTM C270 AND ASTM C387.

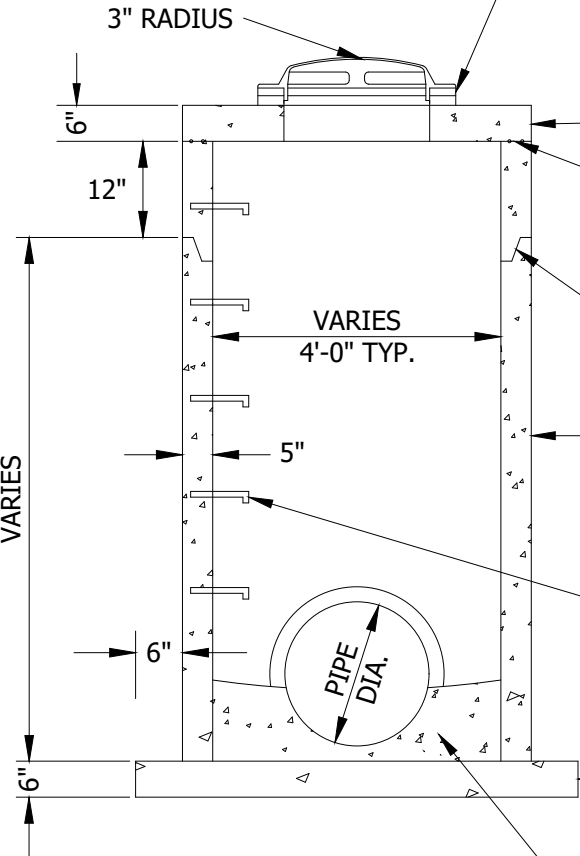

SECTION

6" PRECAST REINFORCED CONCRETE SLAB.

TOP OF BARREL SECTION UNDER TOP SLAB TO HAVE FLAT TOP EDGE SEALED WITH 2 BEADS OF RAMNEK OR APPROVED EQUAL. EXTERNAL SEAL (GATOR WRAP OR APPROVE EQUAL)

ALL JOINTS IN MANHOLE TO HAVE "O" RING RUBBER GASKETS.

PRECAST CONCRETE SECTION

DOGHOUSES SHALL BE GROUTED ON BOTH THE OUTSIDE AND INSIDE.

MANHOLE STEPS, NEENAH R1981J OR EQUAL, 15" O.C., ALUMINUM STEPS APPROVED.

MINIMUM SLAB THICKNESS, 6" FOR STRUCTURES 14" IN DEPTH OR LESS. INCREASE THICKNESS 1" FOR EACH 4' OF DEPTH GREATER THAN 14', AND REINFORCE WITH 6"X6" 10/10 MESH.

GROUT BOTTOM

SEE CITY PLATE NO. STO-09 FOR
RIPRAP PLACEMENT.

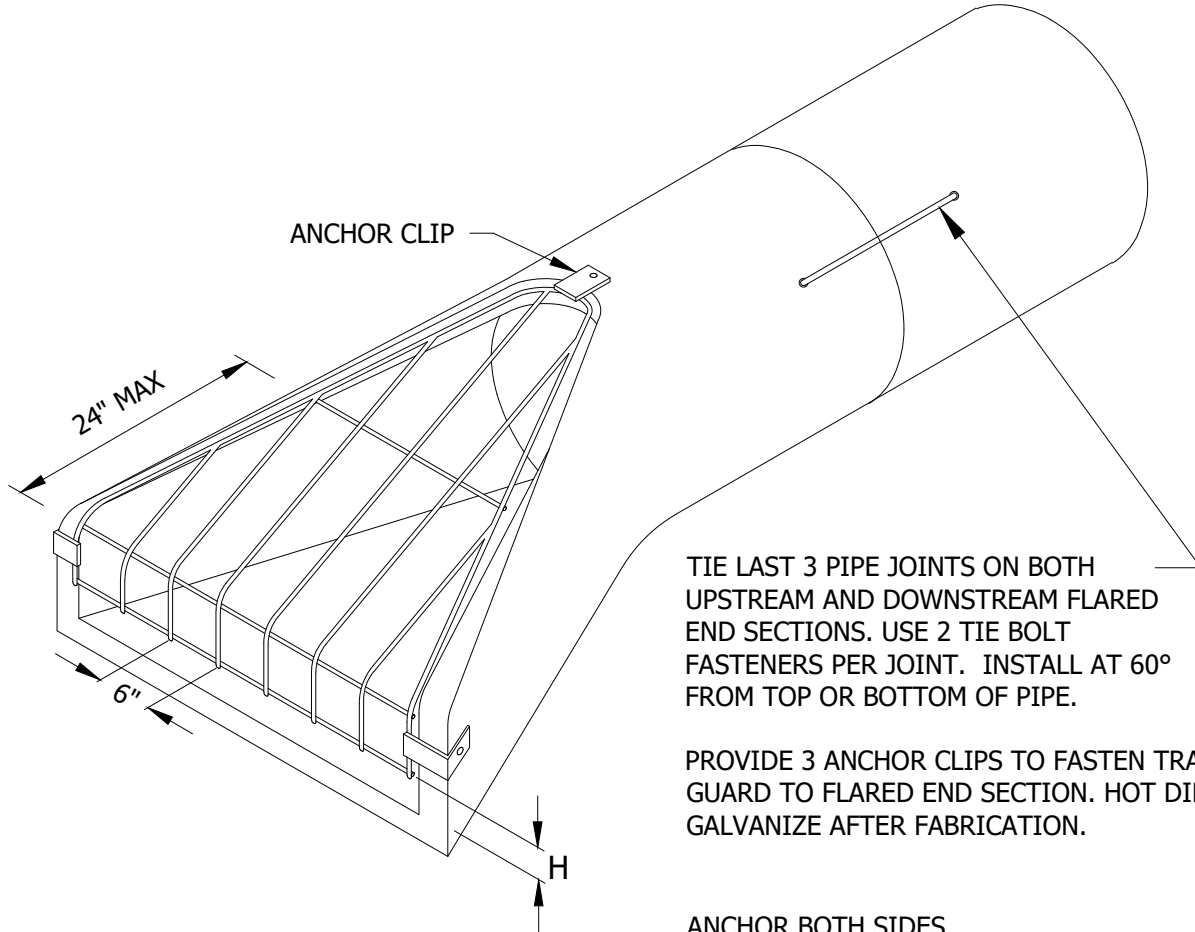

TIE LAST 3 PIPE JOINTS ON BOTH
UPSTREAM AND DOWNSTREAM FLARED
END SECTIONS. USE 2 TIE BOLT
FASTENERS PER JOINT. INSTALL AT 60°
FROM TOP OR BOTTOM OF PIPE.

PROVIDE 3 ANCHOR CLIPS TO FASTEN TRASH
GUARD TO FLARED END SECTION. HOT DIP
GALVANIZE AFTER FABRICATION.

ANCHOR BOTH SIDES.

ISOMETRIC

TRASH GUARD SIZING

PIPE SIZE	BARS	'H'	BOLTS
12"-18"	3/4"Ø	4"	5/8"
21"-42"	1"Ø	6"	3/4"
48"-72"	1 1/4"Ø	12"	1"

NOTES:

1. SEE DETAIL STO-09A FOR FLARED END INSTALLATION IN SANDY MATERIAL.
2. INSTALL TRASH GUARD FOR ALL INLET FLARES AND FOR ALL FLARES LESS THAN 42"



2026 DETAIL PLATES
REV.1

FLARED END SECTION
AND TRASH GUARD

LAST REVISION:
OCT 2024

PLATE NO.
STO-08

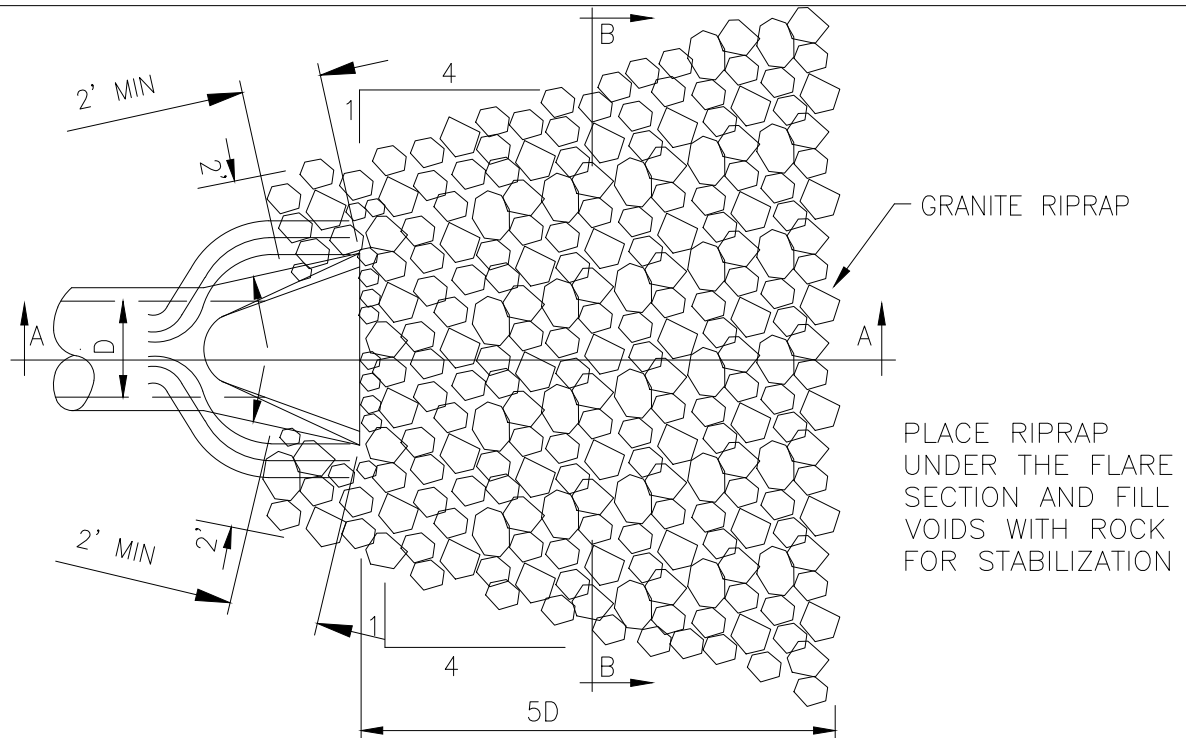

RIPRAP REQUIREMENTS

12" TO 18"	8-10 CUBIC YARDS	CL.3
21" TO 27"	12-14 CUBIC YARDS	CL.3
30" TO 36"	16-24 CUBIC YARDS	CL.3
42" TO 48"	30-38 CUBIC YARDS	CL.3
54" AND UP	62&UP CUBIC YARDS	CL.4

PLAN

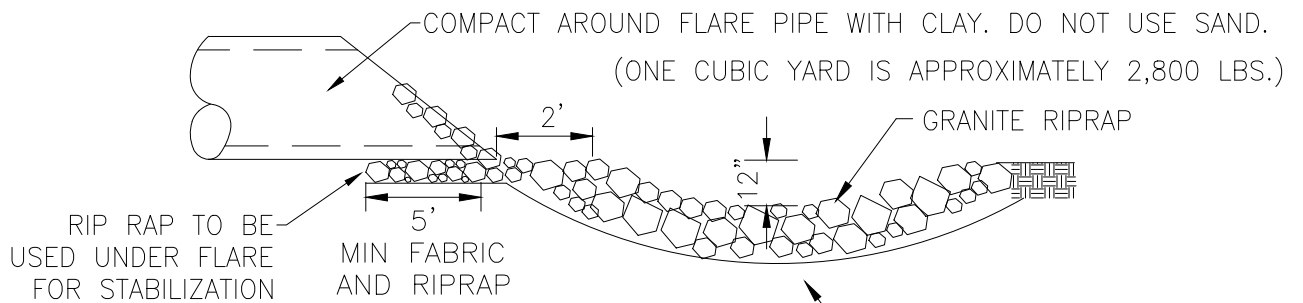

SECTION A-A

NOTES:

1. FILTER BLANKET REQUIRED UNDER RIPRAP OR 2 LAYERS OF 500X MIRAFI FABRIC OR EQUAL.
2. ONLY GRANITE RIPRAP TO BE USED AT OUTLETS.
3. GRADE A SWALE ADJACENT TO BOTH SIDES OF PIPE TO DIRECT WATER AWAY FROM FES.

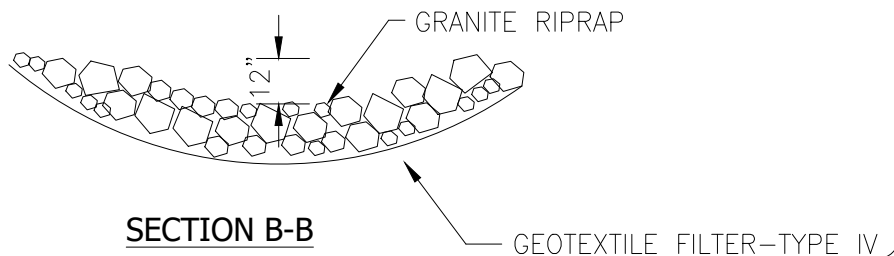

SECTION B-B

(3) 1-1/4" HOLES
 USE 3-1" BY 1' L-SHAPE
 BOLTS AND TIE TO REBAR
 VERTICAL AND HORIZONTAL

12" TYPICAL
 3G52 CONCRETE

SEE DETAIL STO-09
 FOR RIPRAP SECTION

2'-0" TYP.

PLAN

NOTES: TIE LAST 3 JOINTS

2'-0" TYP.

3Y43 CONCRETE

#4 EACH FACE
 1'-0" (TYP.)
 HORIZONTAL

SHEET PILE LIGHTWEIGHT
 ASTM A-857, GR 33 TO 36
 OR A-525 SUPER 5-5 GA

SHEET
 PILING

#3 AT 12" O.C.
 STAGGERED
 VERTICAL

7'-0" TYP.

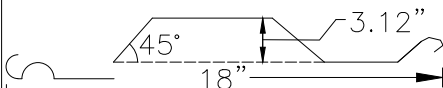

16.9 IBS / FT.
 .209 THICKNESS

OUTSIDE WITH OF END
 SECTION PLUS 4'-0"

ELEVATION

NOTES:

1. FLARED END SECTION 21" IN DIAMETER OR LARGER (TYP.) TRASH GUARDS WILL BE GALVANIZED. SEE DETAIL STO-08.
2. BRING CONCRETE HEADWALL UP TO A POINT THAT WILL NOT HINDER THE OPERATION OF THE TRASH GUARD.
3. USE AS DIRECTED BY CITY ENGINEER.

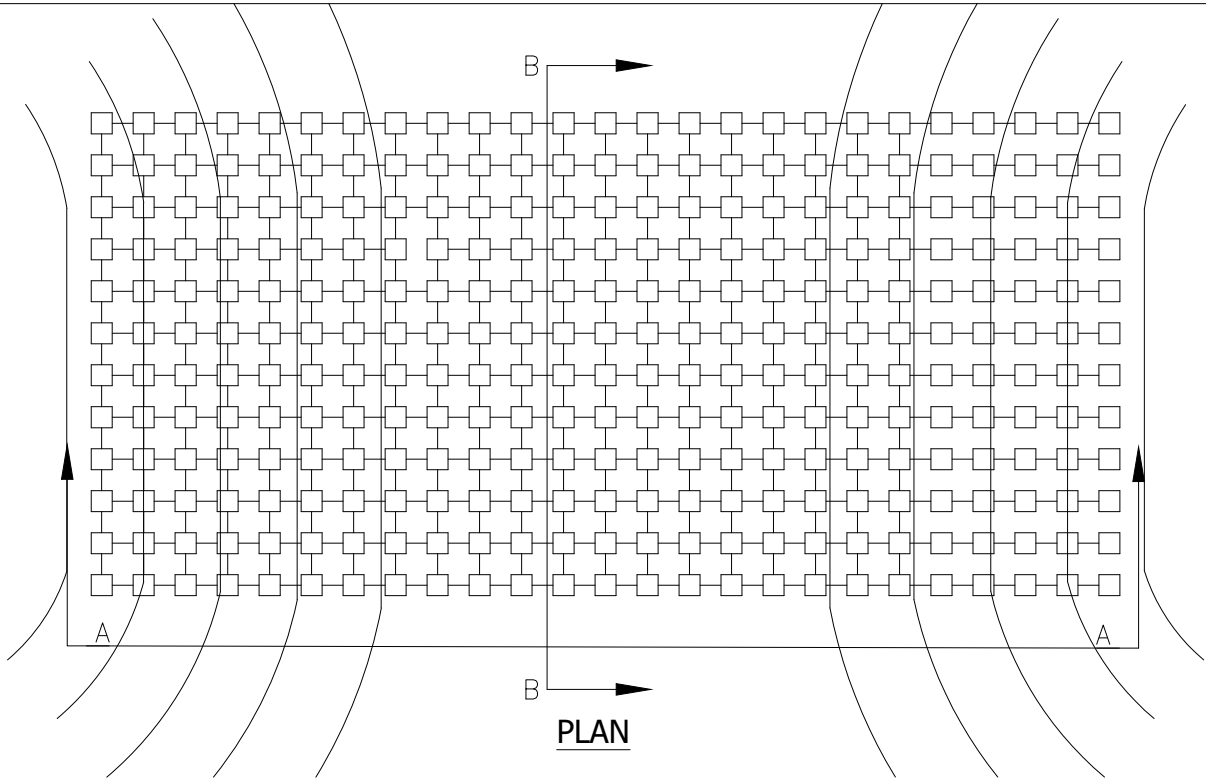

PLAN

10' MIN

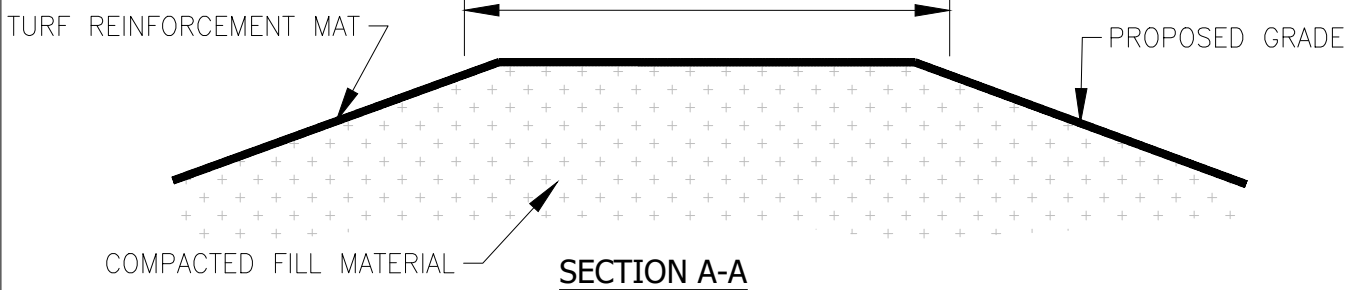

SECTION A-A

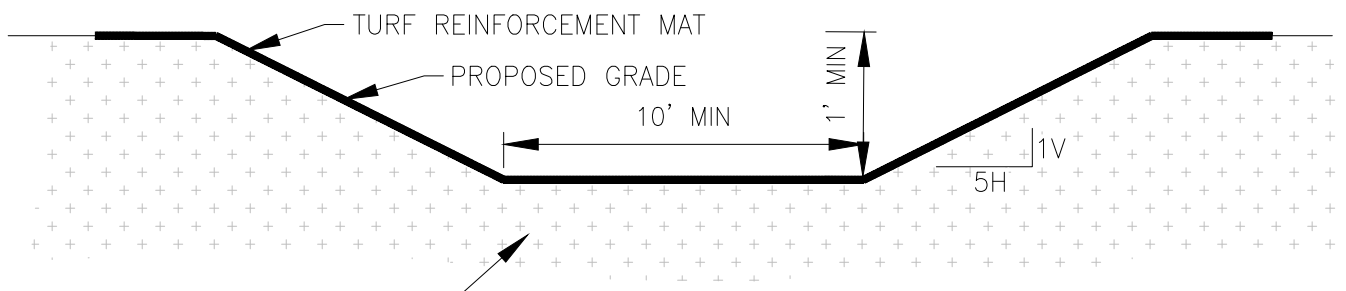

SECTION B-B

NOTES:

1. TURF REINFORCEMENT MAT TO BE INSTALLED TO WATER LEVEL ON INLET SIDE AND DISCHARGE ELEVATION ON OUTLET SIDE.
2. TURF REINFORCEMENT MAT SHALL BE MNDOT ROLLED EROSION PREVENTION PRODUCT – CATEGORY 76, SLOPETAME3 BY INVISIBLE STRUCTURES, OR CITY APPROVED EQUAL AND INSTALLED PER MANUFACTURER’S RECOMMENDATIONS.



2026 DETAIL PLATES
REV.1

TYPICAL POND EOF

LAST REVISION:
DEC 2025

PLATE NO.
STO-10

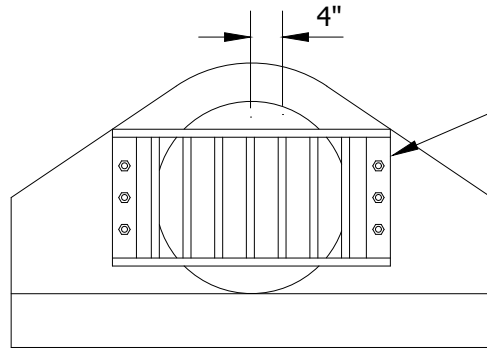

STEEL PLATE - BOLT TO CONCRETE WITH STAINLESS STEEL BOLTS. HOT DIP GALVANIZE AFTER FABRICATION.

FRONT VIEW

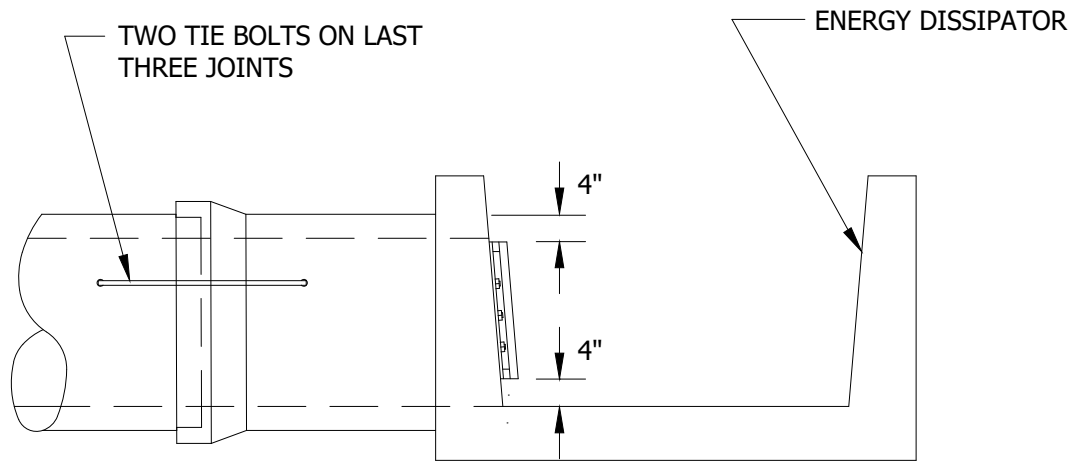

SIDE VIEW

SIZE OF PIPE	SIZE OF PLATE	BARS	BOLTS
12" TO 18"	1/4" X 2"	3/4"Ø	2-5/8"Ø
21" TO 48"	1/4" X 3"	1"Ø	3-3/4"Ø

NOTE:

TIE LAST 3 JOINTS. USE 2 TIE BOLT FASTENERS PER JOINT INSTALLED AT 60Ø FROM TOP OR BOTTOM OF PIPE.



2026 DETAIL PLATES
REV.1

**ENERGY DISSIPATOR
AND TRASH GUARD**

LAST REVISION:
OCT 2024

PLATE NO.
STO-11

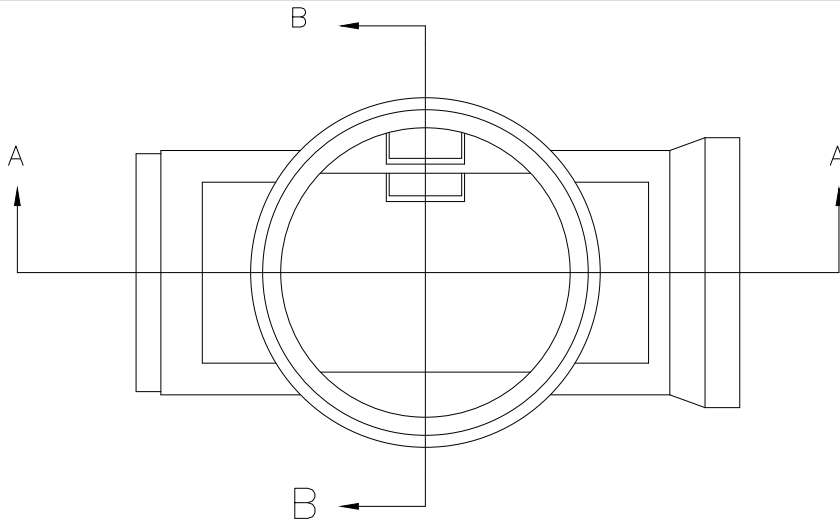

MANHOLE STEPS
NEENAH R1980J OR
EQUAL 16" O.C.

TOP VIEW

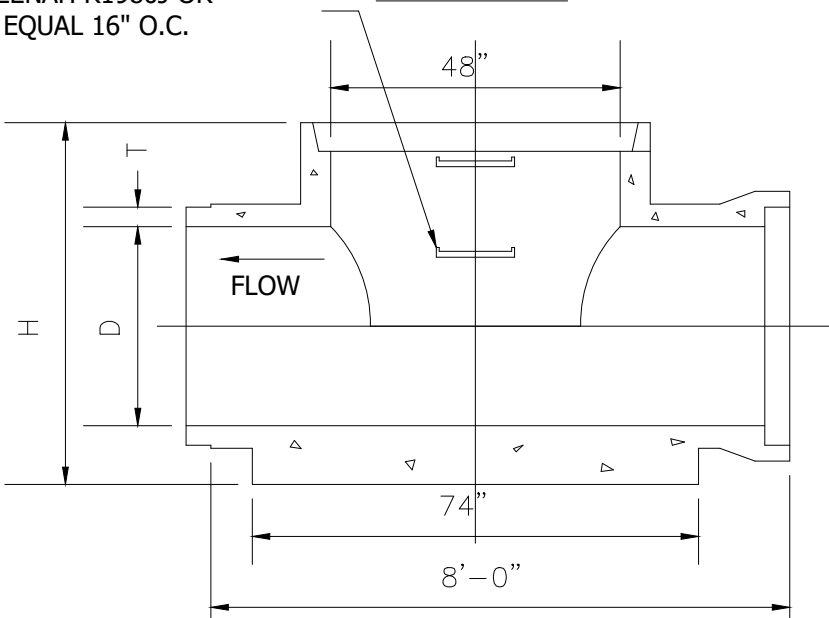

SIDE VIEW

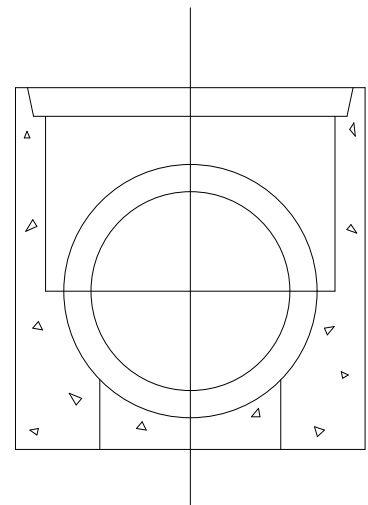

END VIEW

PIPE DIAMETER "D"	"B" WALL THICKNESS "T"	"C" WALL THICKNESS "T"	"B" WALL HEIGHT "H"
12"	2"	2 3/4"	36"
15"	2 3/4"	3"	36"
18"	2 1/2"	3 1/4"	48"
21"	2 3/4"	3 1/2"	48"
24"	3"	3 3/4"	48"
27"	3 1/4"	4"	60"
30"	3 1/2"	4 1/4"	60"
33"	3 3/4"	4 1/2"	60"
36"	4"	4 3/4"	60"

NOTE:

1. ALL PIPES SHALL HAVE R-4 RUBBER GASKET JOINT.
2. HORIZONTAL PIPE MAY BE "B" WALL OR "C" WALL.



2026 DETAIL PLATES
REV.1

"MINI-TEE" MANHOLE

LAST REVISION:
OCT 2024

PLATE NO.
STO-12

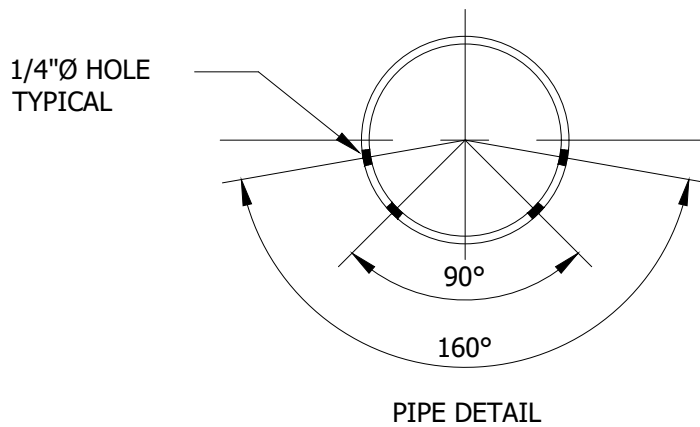
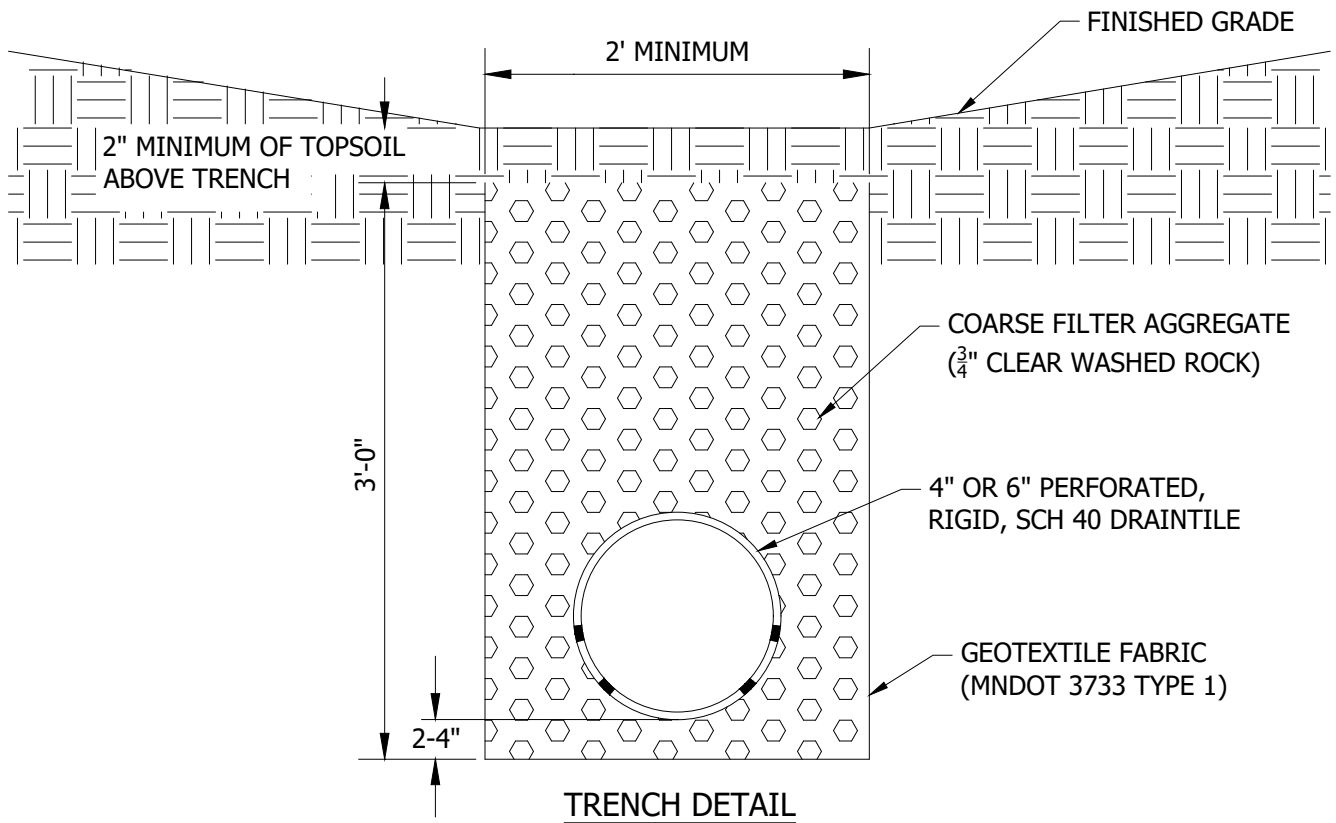

NOTES:

1. FABRIC TO BE WRAPPED ON THE SIDES OF AND UNDER THE FILTER AGGREGATE. DO NOT WRAP FABRIC OVER TOP OF AGGREGATE.
2. PLACE HOLES UP WHEN SUMP PUMP LATERALS ARE PRESENT.
3. DO NOT USE FILTER SOCK AROUND PIPE.

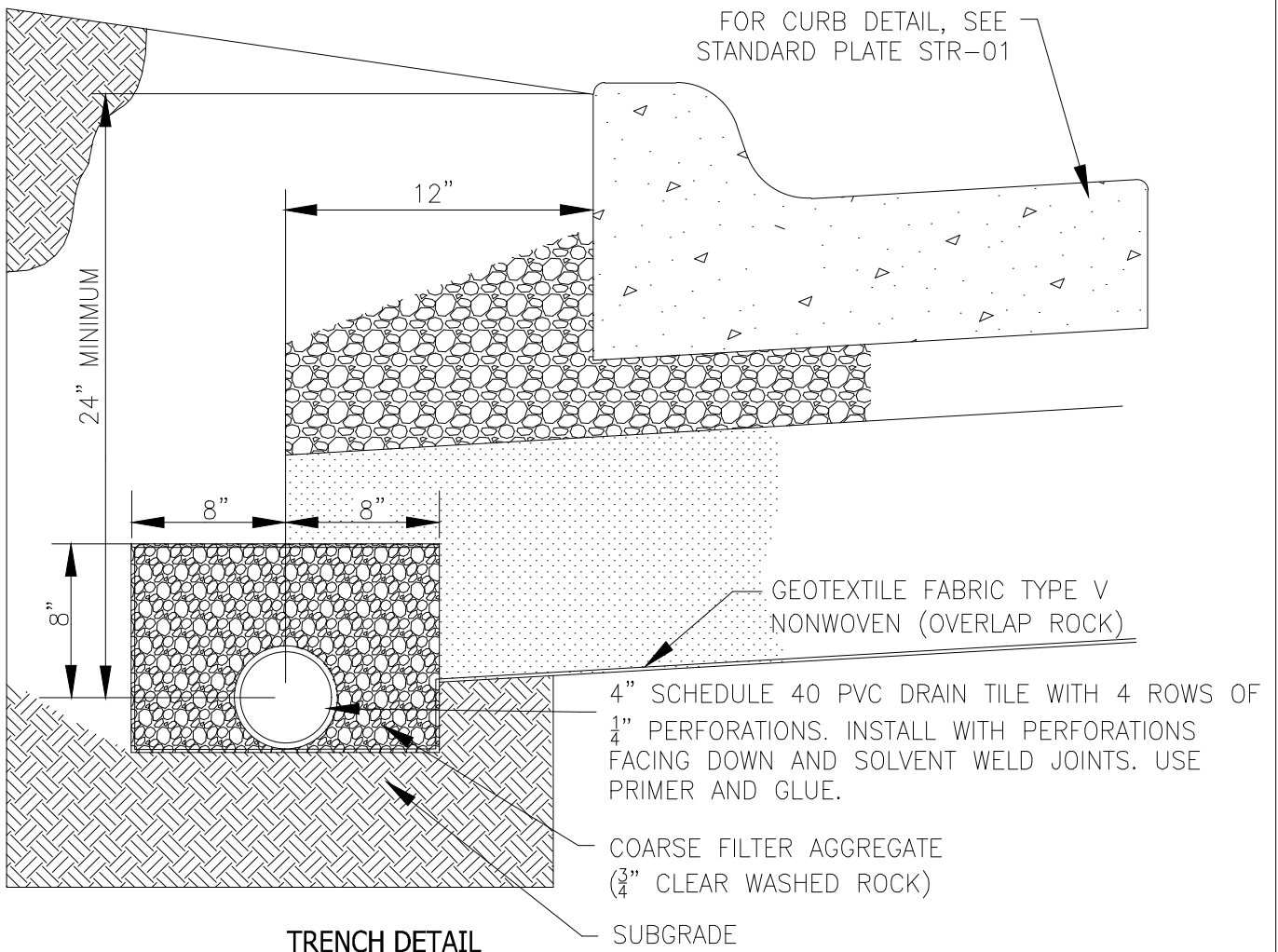

NOTES:

1. PLACE SUB-DRAIN BEHIND ALL CURB & GUTTER 250 LF IN EACH DIRECTION FROM CATCH BASINS LOCATED AT LOCALIZED LOW POINTS AND 150 LF UPSTREAM FROM CATCH BASINS LOCATED IN THE MID-SLOPE. THESE ARE THE MINIMUM LENGTHS REQUIRED. LENGTHS MAY BE ADJUSTED IN THE FIELD BY THE ENGINEER BASED ON SITE CONDITIONS.
2. CONNECT SUB-DRAIN TO NEAREST CATCH BASIN. CONNECTION TO BE CORE-DRILLED. DOGHOUSES MUST BE GROUTED ON BOTH THE INSIDE AND OUTSIDE OF THE STRUCTURE.
3. ALL STREETS WITH GRADES LESS THAN 1% WILL REQUIRE STREET DRAIN TILE.
4. SLOPE SUB-DRAIN TO CATCH BASIN.
5. SUB-DRAIN MAY BE DAYLIGHT TO DITCH AS APPROVED BY CITY ENGINEER
6. CLEANOUTS ARE REQUIRED AT A MAXIMUM OF 300 FOOT INTERVALS, AT BENDS, AND AT THE END OF THE RUN. SEE DETAIL STO-18 FOR CLEANOUT FABRICATION.
7. CLEANOUTS TO BE LOCATED AT PROPERTY CORNERS.
8. IF CLEANOUT IS TO BE LOCATED WITHIN 50' OF CATCH BASIN REMOVE CLEANOUT AND TIE DRAIN TILE INTO THE CATCH BASIN.
9. CONTRACTOR TO TELEWISE DRAIN TILE AFTER PRIVATE UTILITIES ARE INSTALLED AND PRIOR TO ACCEPTANCE OF STREET. NOTIFY THE ENGINEER WHEN TELEVISIONING AND SUBMIT VIDEOS WITH REPORT TO THE ENGINEER.

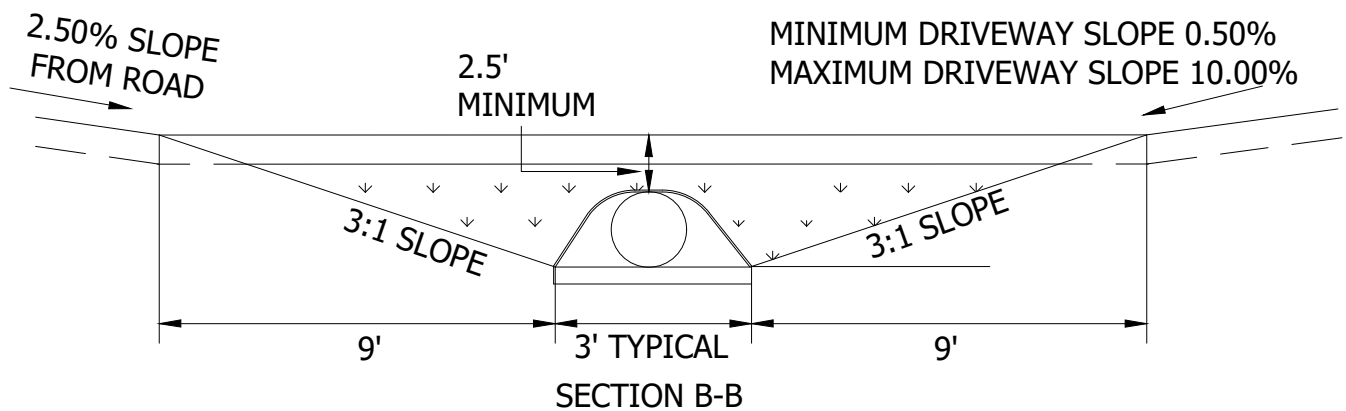
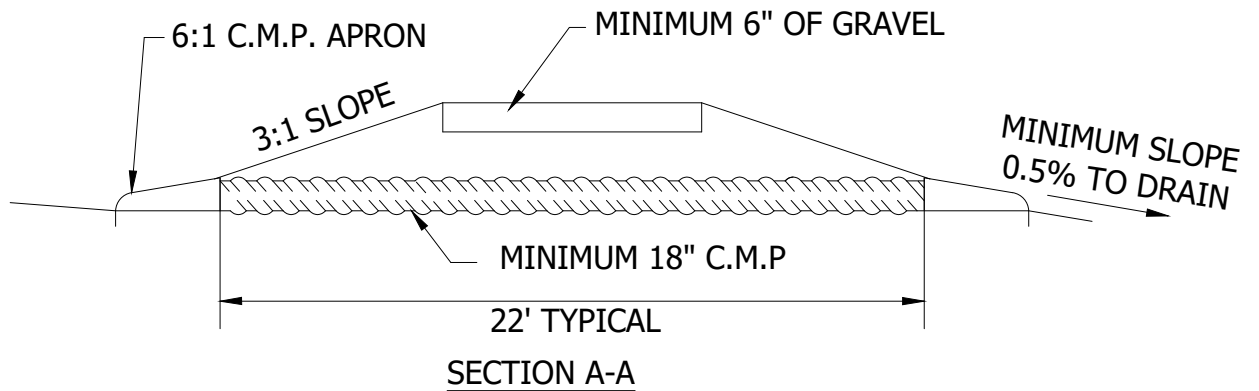
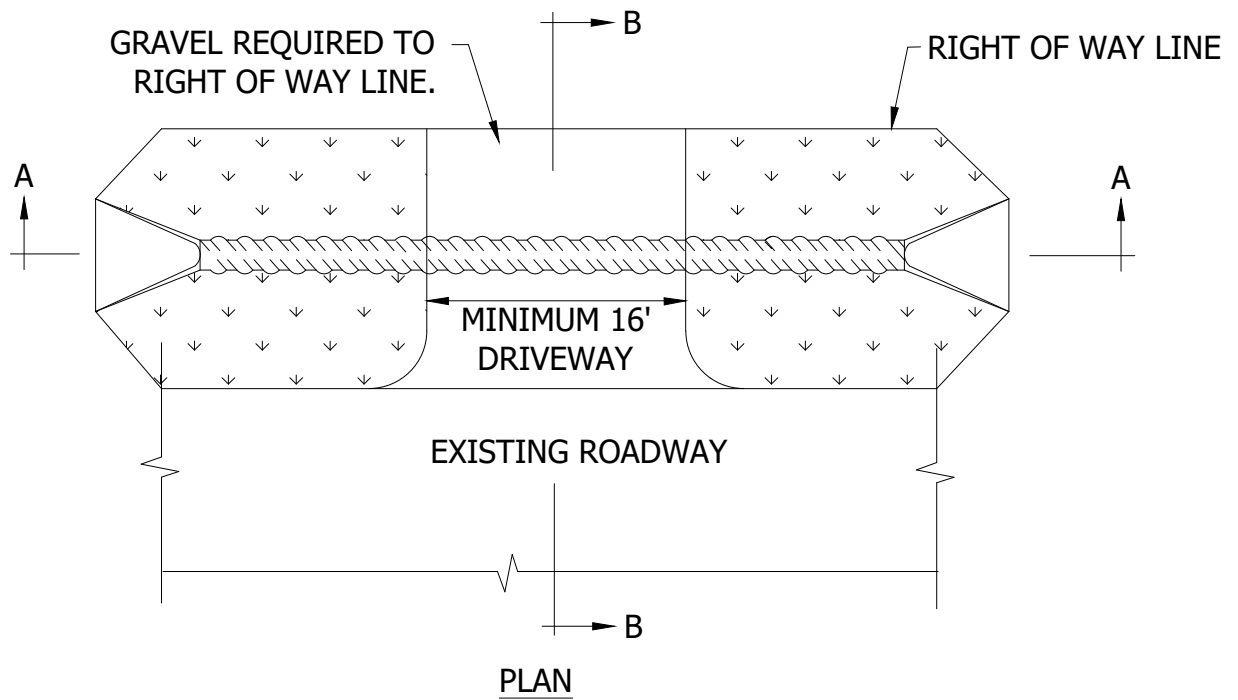

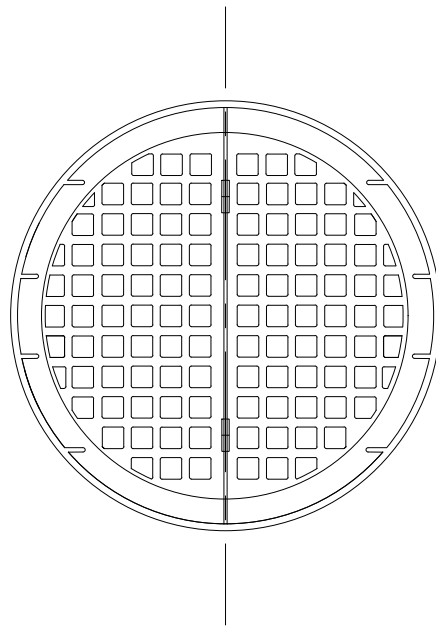

HAALA POND
SKIMMER PLATE
STYLE OR
APPROVED EQUAL.

GRATE DETAIL

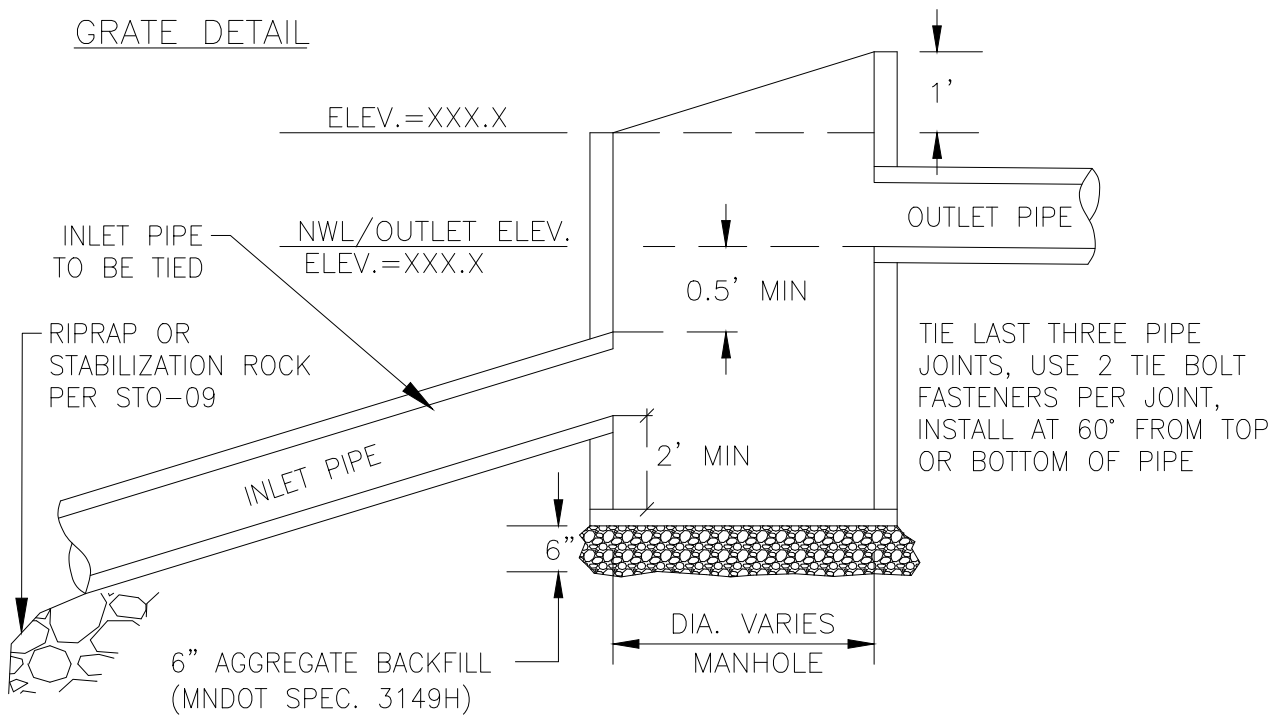

2026 DETAIL PLATES
REV.1

STORM SEWER SKIMMER STRUCTURE

LAST REVISION:
OCT 2024

PLATE NO.
STO-15

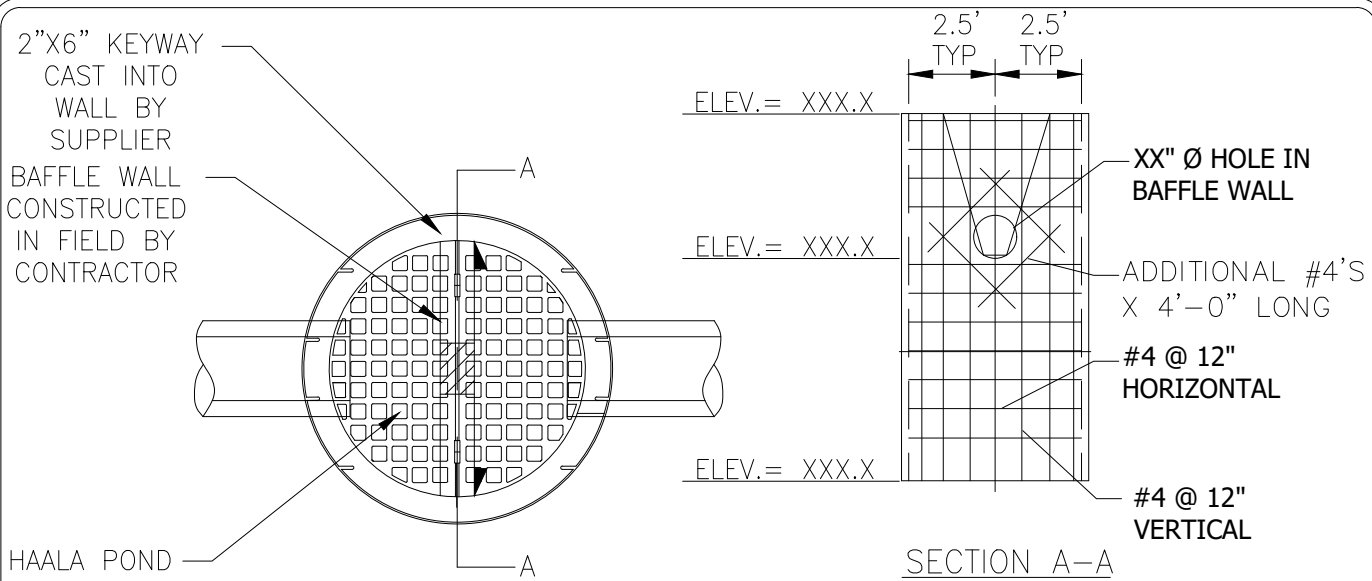

2"X6" KEYWAY
CAST INTO
WALL BY
SUPPLIER

BAFFLE WALL
CONSTRUCTED
IN FIELD BY
CONTRACTOR

HAALA POND
SKIMMER
PLATE STYLE
OR
APPROVED
EQUAL.

SKIMMER GRATE

CONCRETE BAFFLE WALL

WHEN FEASIBLE, SET INVERT FOR OUTLET PIPE BELOW
NWL TO IMPROVE PIPE COVER AND MINIMIZE SLOPE
AROUND SKIMMER

NOTE:

1. BAFFLE WALL TO BE SINGLE PIECE AND WATERTIGHT.
2. SIKAFLEX SEALANT OR APPROVED EQUAL TO BE USED TO MAKE WATERTIGHT.
3. WHEN BAFFLE WALL HEIGHT IS GREATER THAN 3' ABOVE NWL THE FOLLOWING SHALL BE REQUIRED:
 - STEPS
 - 6' DIAMETER MH

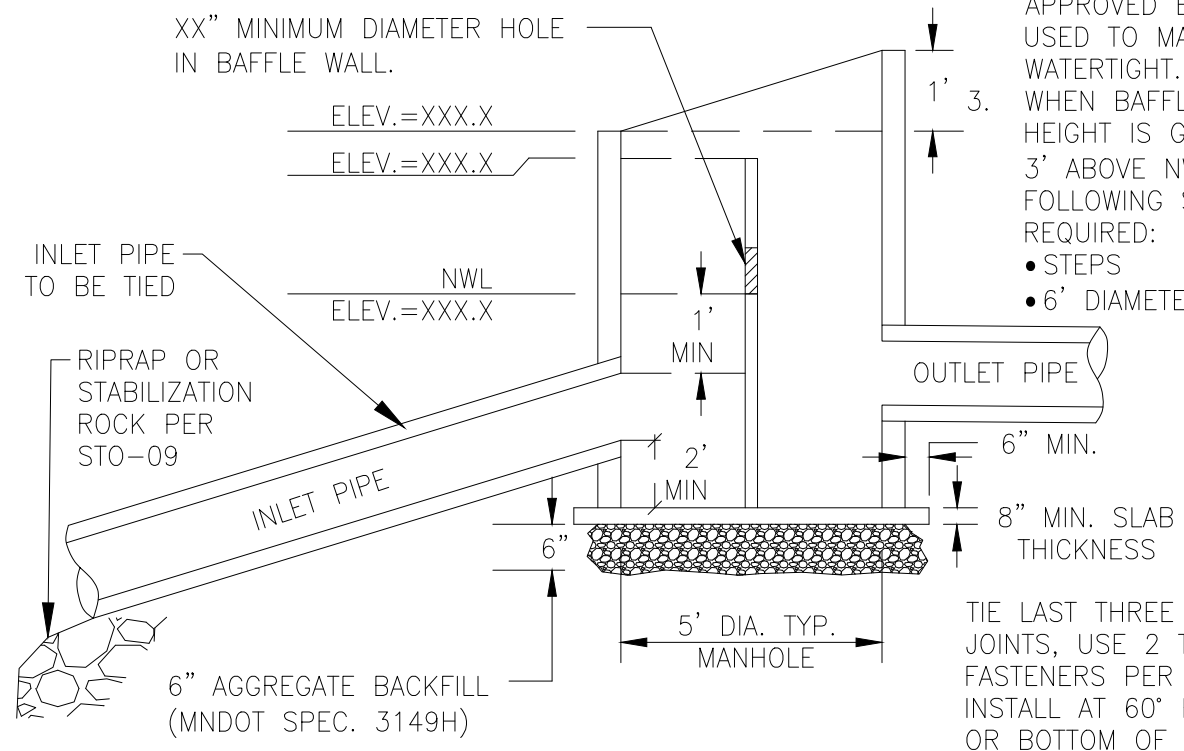

**STORM SEWER SKIMMER STRUCTURE WITH
CONCRETE BAFFLE WALL**

LAST REVISION:
DEC 2025

PLATE NO.
STO-16

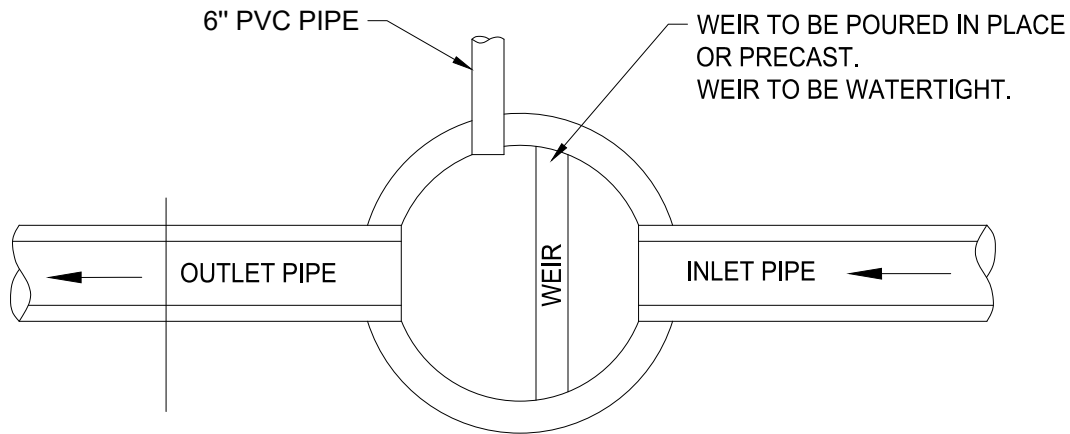

PLAN VIEW

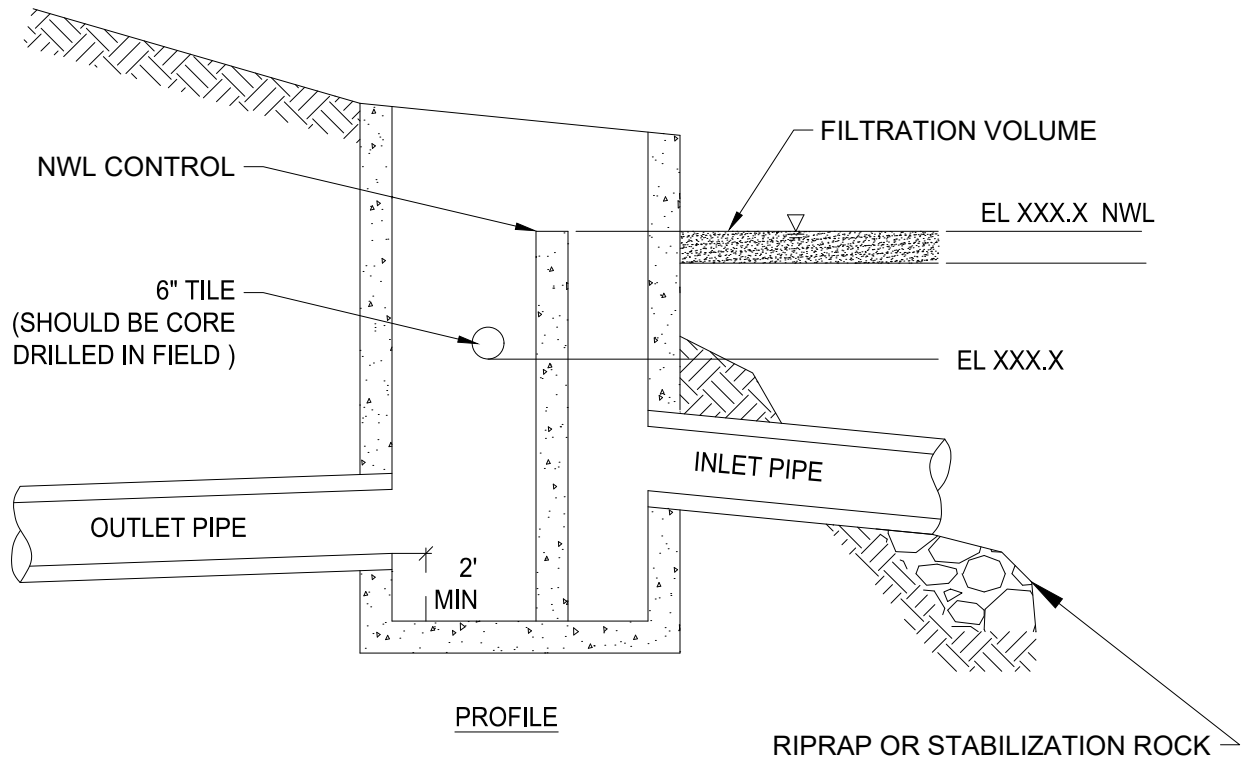

PROFILE

NOTE:
 TILE MUST CONNECT TO STRUCTURE.
 TILE MUST BE ABOVE THE TOP OF OUTLET PIPE AND APPROXIMATELY 1 FOOT BELOW ELEVATION OF TILE IN THE TRENCH.
 INLET PIPE SHALL BE TIED AT ALL JOINTS AND ATTACHED TO THE STRUCTURE.

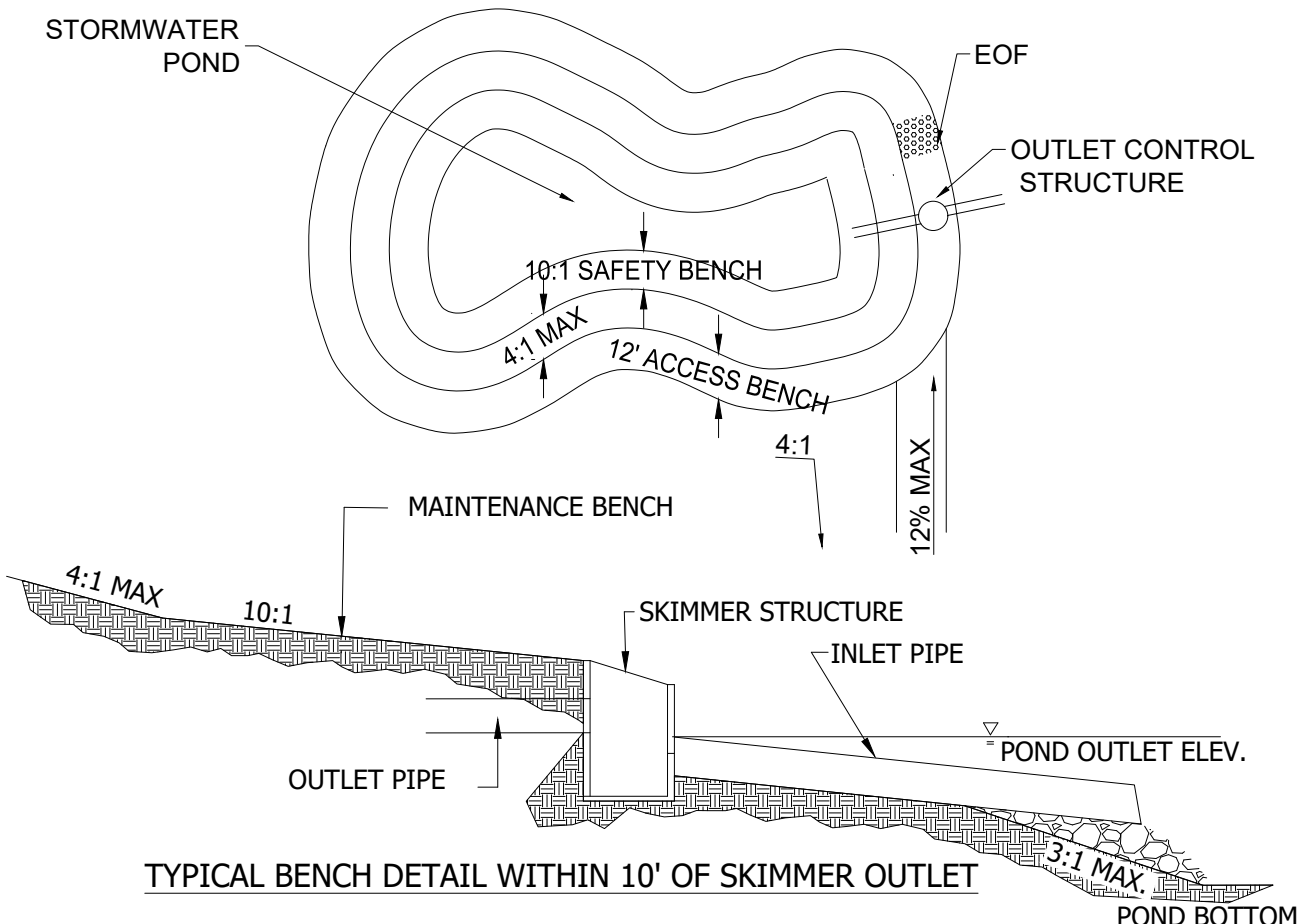

TYPICAL BENCH DETAIL WITHIN 10' OF SKIMMER OUTLET

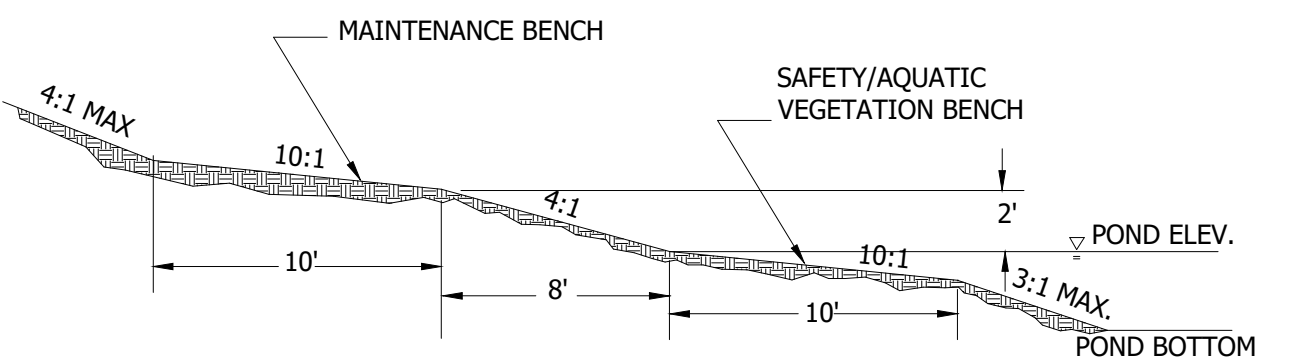

TYPICAL BENCH DETAIL

- NOTES:**
1. SEE CITY PLATE STO-15 OR STO-16 FOR SPECIFIC SKIMMER STRUCTURE DETAILS.
 2. INLET PIPE SHALL BE TIED AT ALL JOINTS AND ATTACHED TO THE STRUCTURE.

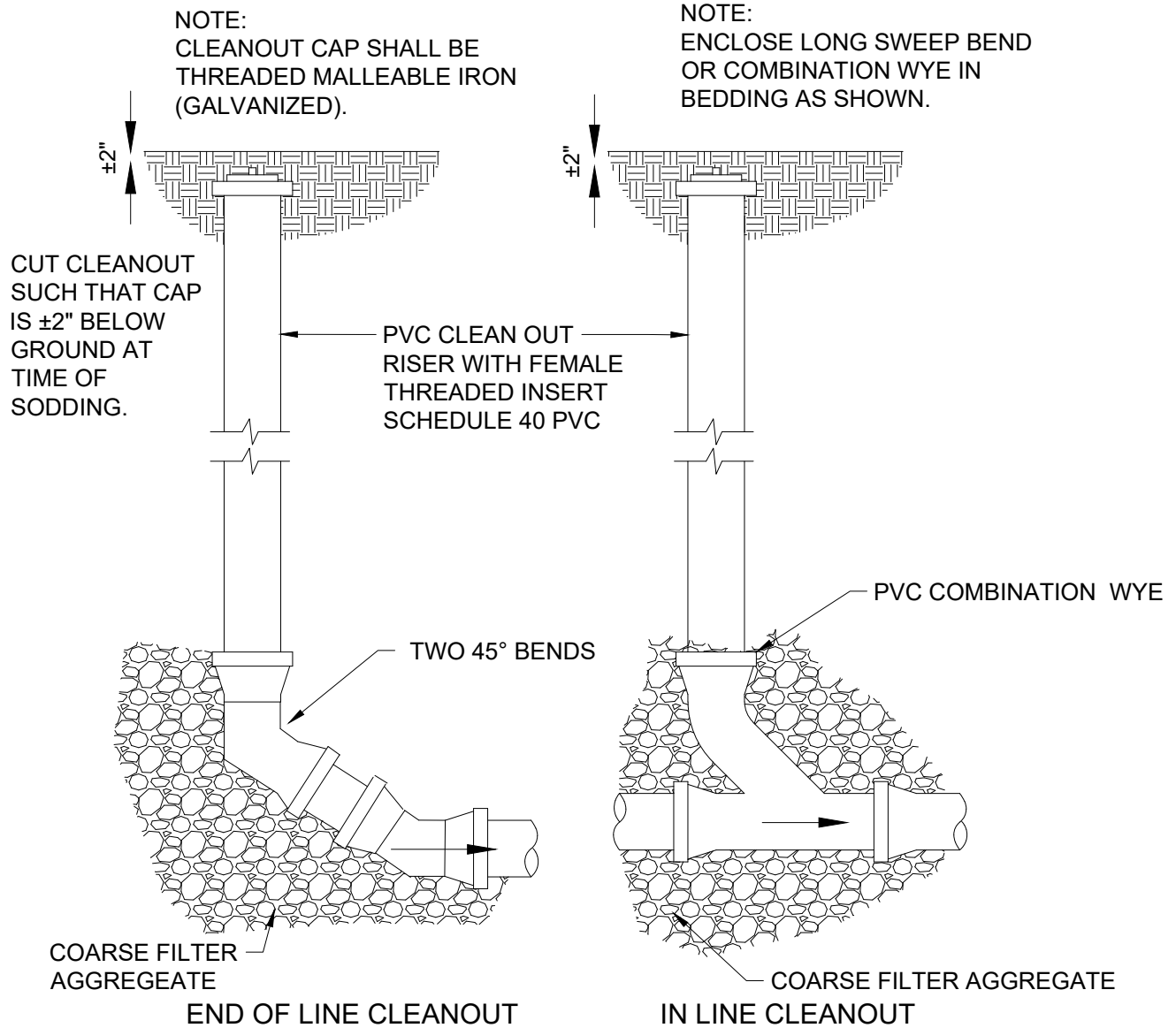

NOTE:

1. IF CLEANOUT IS IN DRIVEWAY, CONTRACTOR MUST INSTALL FORD A-1 CASTING, MARKED WITH "SEWER ON LID.
2. IF CLEANOUT IS IN ROADWAY, CONTRACTOR MUST INSTALL TOP SECTION OF A VALVE BOX WITH LID MARKED "SEWER".
3. CLEANOUTS ARE REQUIRED AT MAXIMUM 300' INTERVALS, AT BENDS, AND AT THE END OF THE RUN. IF CLEANOUT IS LOCATED WITHIN 50' OF CATCH BASIN, TIE DRAIN TILE INTO CATCH BASIN
4. CLEANOUTS TO BE INSTALLED AT PROPERTY CORNERS.
5. ADDITIONAL CLEANOUTS TO BE INSTALLED AS DIRECTED BY ENGINEER.

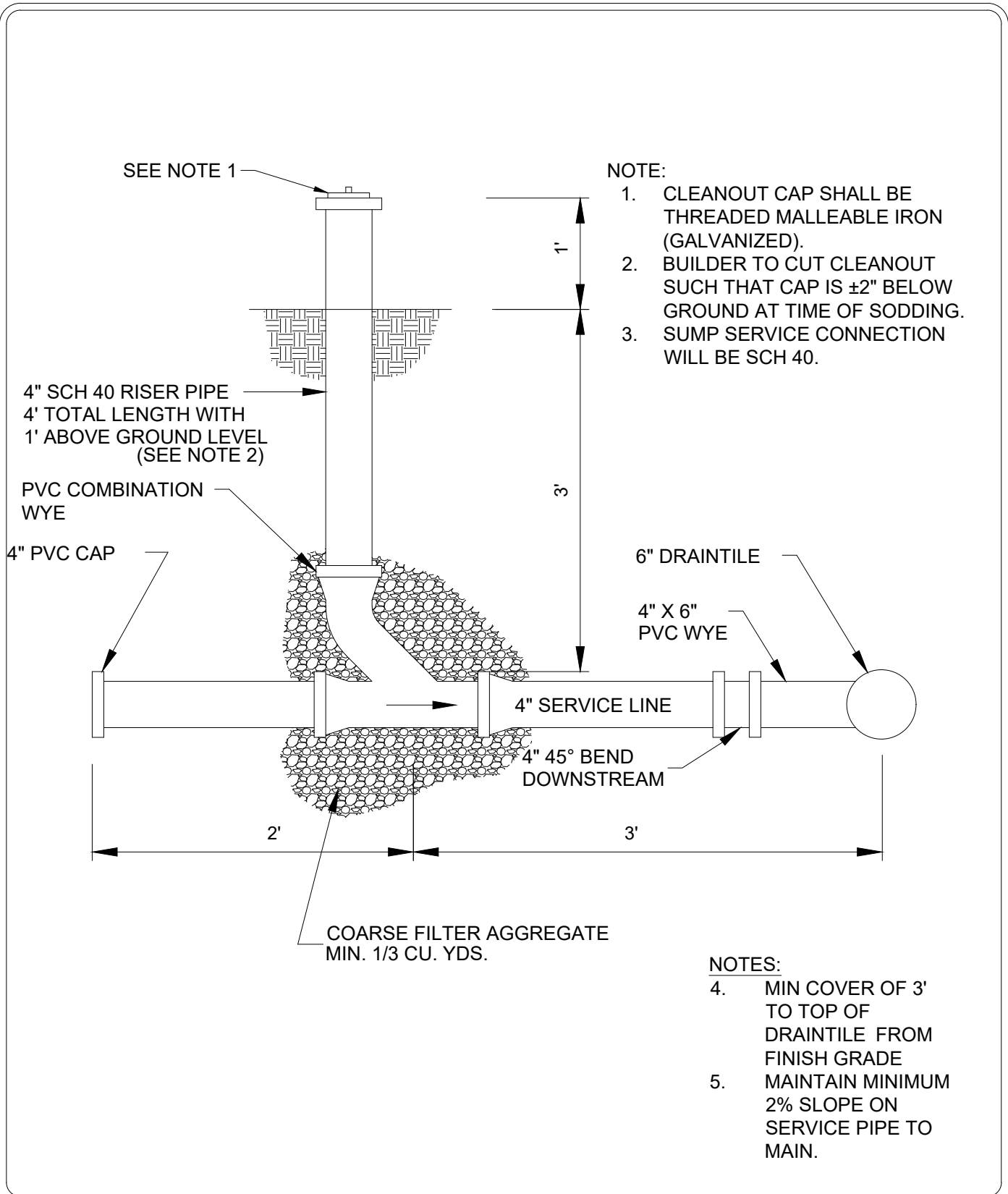

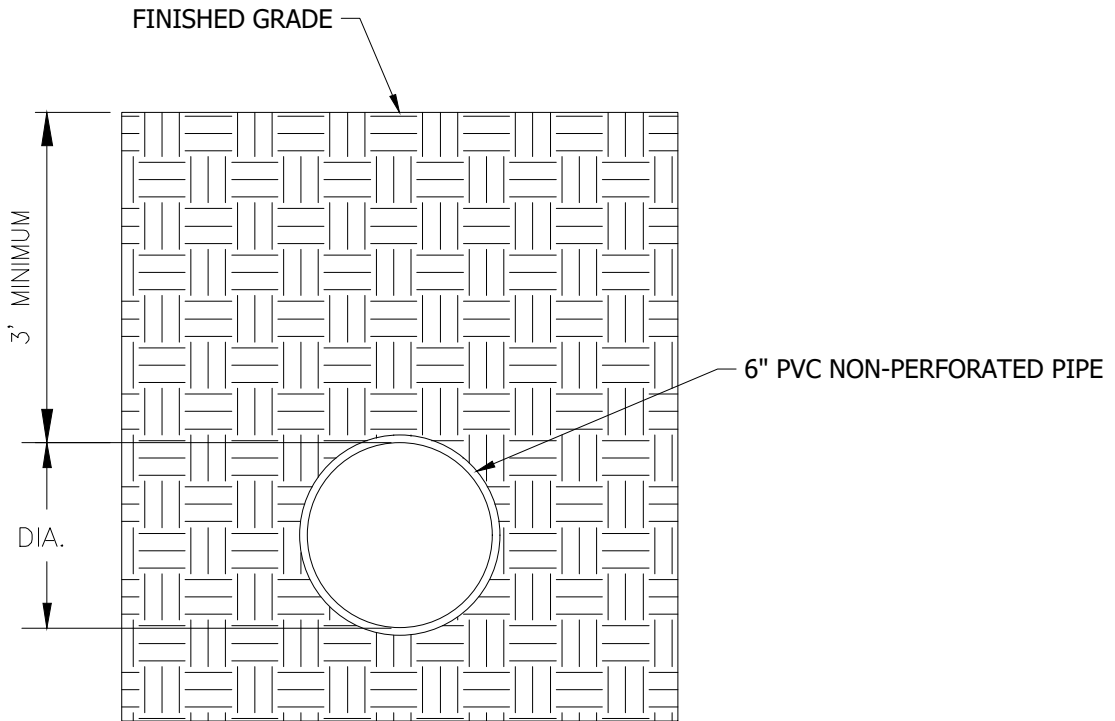

TRENCH DETAIL

NOTES:

1. MINIMUM COVER OF 3' TO TOP OF DRAINTILE FROM FINISHED GRADE.
2. MAINTAIN MINIMUM 2% SLOPE ON SERVICE PIPE TO MAIN.
3. CONNECTION PER STO-19.
4. **ALL BACKYARD SUMP TILE LOCATED IN A DRAINAGE SWALE MUST BE PERFORATED WITH THE HOLES UP. REFERENCE STO-13 FOR INSTALLATION.**



2026 DETAIL PLATES
REV.1

BACKYARD DRAIN TILE FOR
SUMP CONNECTIONS

LAST REVISION:
DEC 2025

PLATE NO.
STO-20

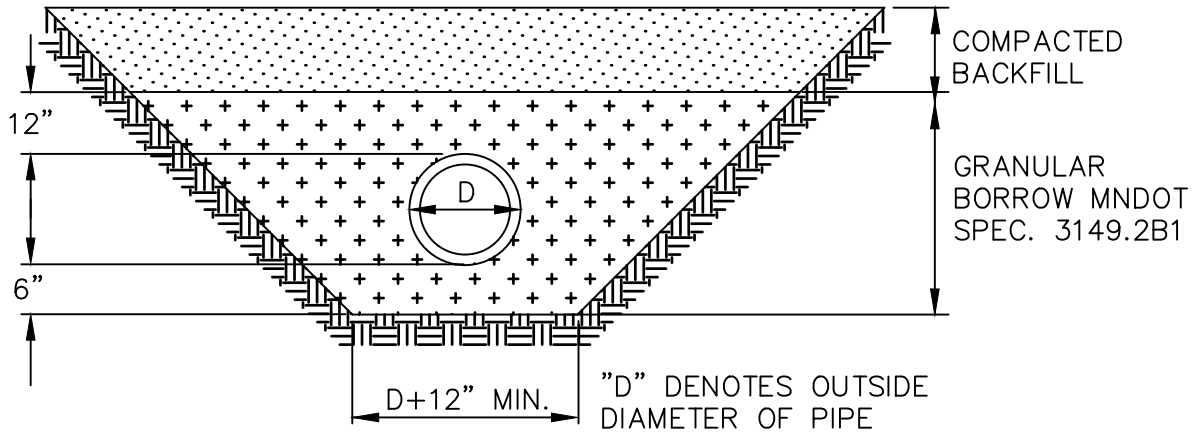

PIPE FOUNDATION & BEDDING IN GOOD SOILS

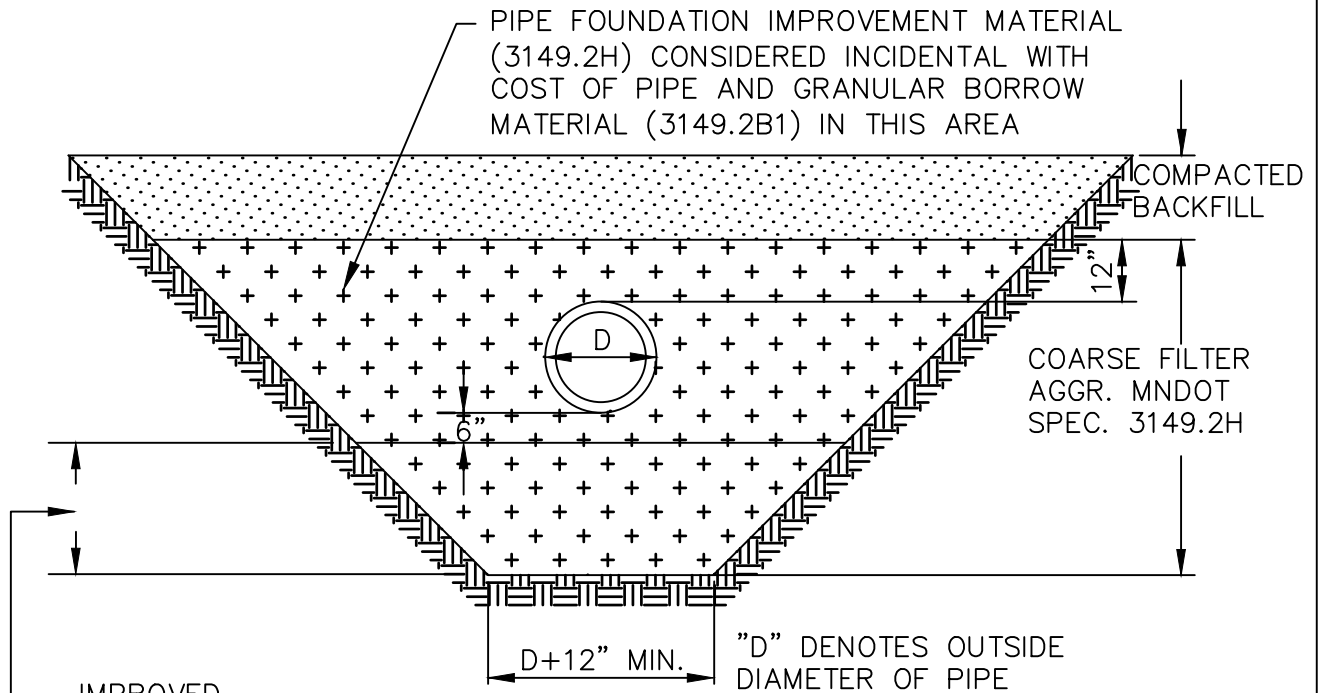

PIPE FOUNDATION & BEDDING IN POOR SOILS

NOTE:

1. SDR-26 SHALL BE USED FOR PIPE DEPTHS 16'-25'. FOR PIPE DEPTHS EXCEEDING 25' C-900 IS TO BE USED.
2. REFERENCE GEN-12 FOR PIPE MATERIAL VS. DEPTH PERFORMANCE.

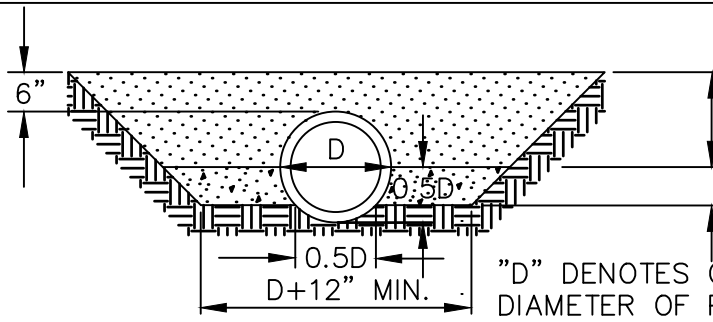

COMPACTED BACKFILL
 2000# CONCRETE
 LOAD FACTOR 2.3
CLASS A
 CONCRETE BACKFILL TO
 0.5 OF OUTSIDE
 DIAMETER OF PIPE WITH SHAPED
 BEDDING.

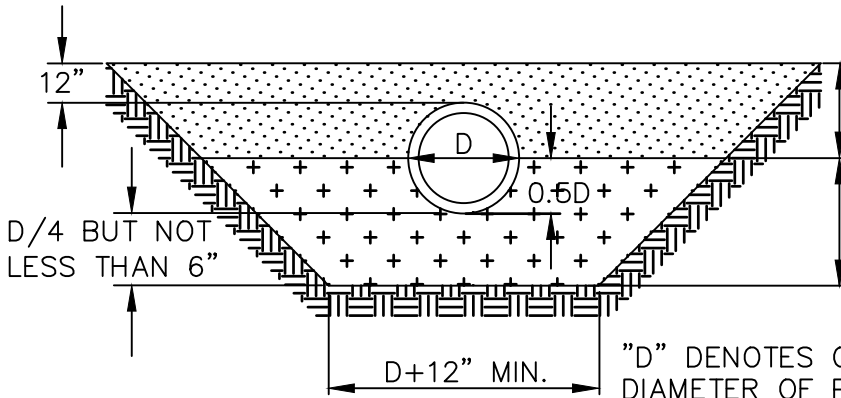

COMPACTED BACKFILL
 COARSE FILTER AGGREGATE
 MNDOT SPEC. 3149.2.H
 LOAD FACTOR 1.9
CLASS B

HAND-SHAPED FROM
 ANGULAR BEDDING MATERIAL

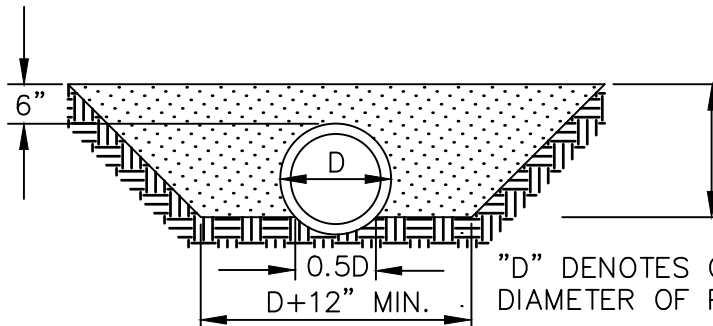

COMPACTED BACKFILL
 LOAD FACTOR 1.5
CLASS C-1
 HAND-SHAPED FROM
 FIRM, UNDISTURBED SOIL

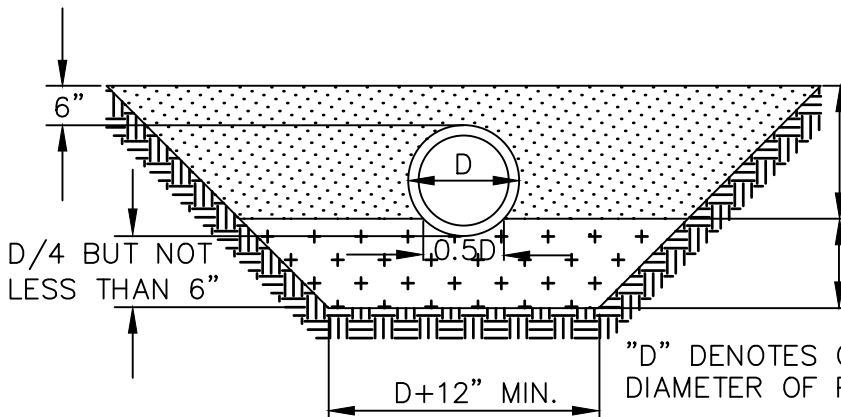

COMPACTED BACKFILL
 COARSE FILTER AGGREGATE
 MNDOT SPEC. 3149.2.H
 LOAD FACTOR 1.5
CLASS C-2
 HAND-SHAPED FROM
 ANGULAR BEDDING MATERIAL

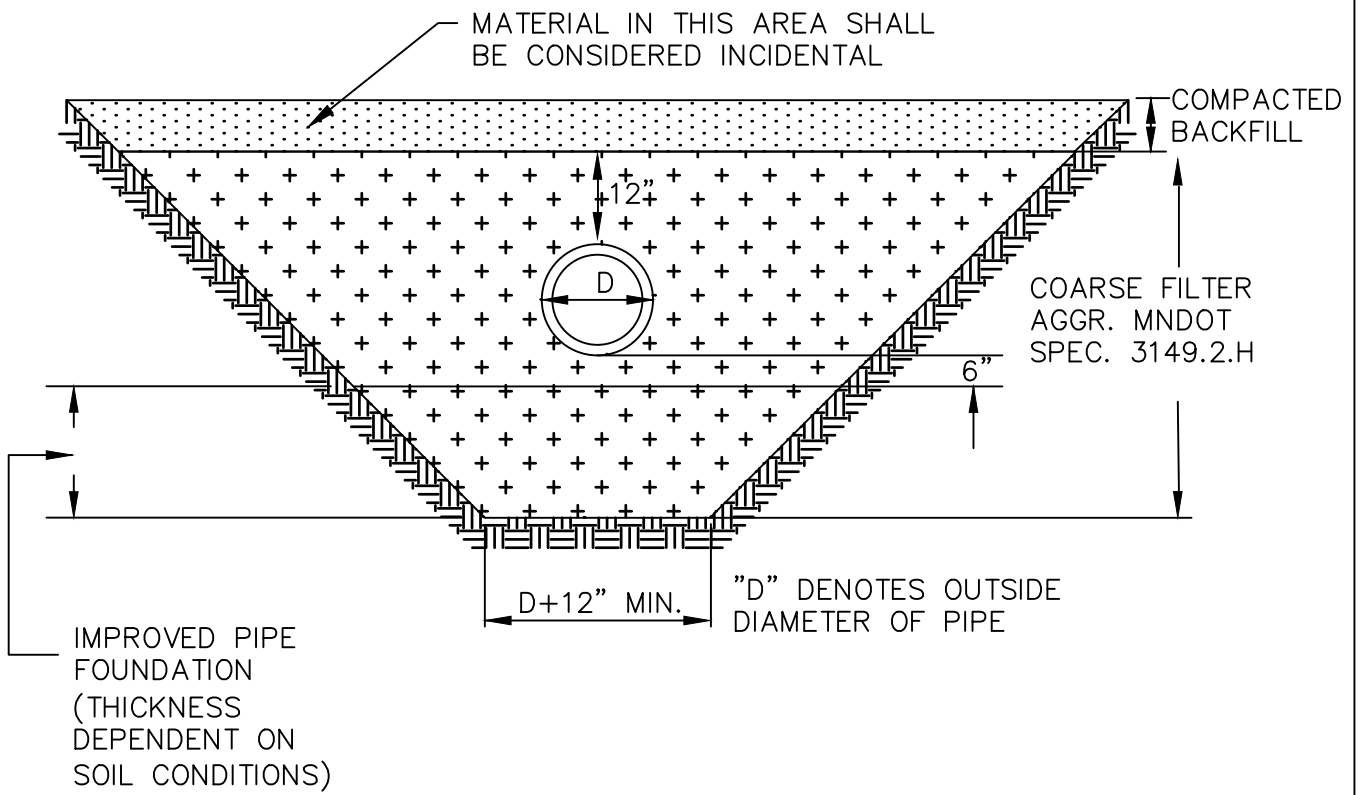

2026 DETAIL PLATES
REV.1

IMPROVED FOUNDATION
FOR RCP AND DIP

LAST REVISION:
OCT 2024

PLATE NO.
BED-03

NOTES:

1. ALL NEW CURB BOXES MUST HAVE RISER RODS. WHEN AN EXISTING CURB BOX IS ON A CONSTRUCTION OR RECONSTRUCTION PROJECT, RISER RODS SHALL BE INSTALLED TO ALL CURB BOXES ON THAT PROJECT.
2. INSTALL SERVICE LINES WITH A 45° RISER TO 6' BELOW FINISHED GROUND.
3. PLACEMENT OF CURB STOP AND BOX ON PRIVATE STREETS SHALL BE 9' OUTSIDE OF THE RIGHT OF WAY.
4. TRACER WIRE SHALL BE BROUGHT TO SURFACE ALONG WATERMAIN CURB STOP. INSTALL SNAKEPIT, OR APPROVED EQUAL TRAFFIC RATED TRACER WIRE ACCESS BOX.
5. MIN OF 1 LB. DRIVE IN ANODES WITH MIN 20' WIRE LEAD ARE TO BE INSTALLED AT EVERY TRACER WIRE ACCESS BOX.
6. TRACER WIRE SHALL BE 12 AWG COPPER CLAD STEEL CORE WIRE WITH MIN BREAK LOAD OF 450 LB FOR OPEN CUT INSTALLATION RATED FOR 30 VOLTS. MIN 45 MIL HMWPE JACKET.
7. TRACER WIRE CONNECTOR SHALL BE DRY CONN DIRECT BURY LUG AQUAL, PRO-TRACE DB OR APPROVED EQUAL.
8. SER-01A TO BE USED ON ANY CONSTRUCTION WITH PREVIOUSLY INSTALLED HDPE FUSED FITTINGS. SER-01B SHALL BE USED ON ANY NEW CONSTRUCTION WHERE FUSED FITTINGS HAVE NOT BEEN INSTALLED IN PREVIOUS PHASING OR CONTAINING PREVIOUSLY INSTALLED COMPRESSION FITTINGS
9. CONTRACTOR MUST SUPPLY 1 CURBSTOP KEY PER 50 SERVICES OR PHASE, WHICHEVER IS GREATER.

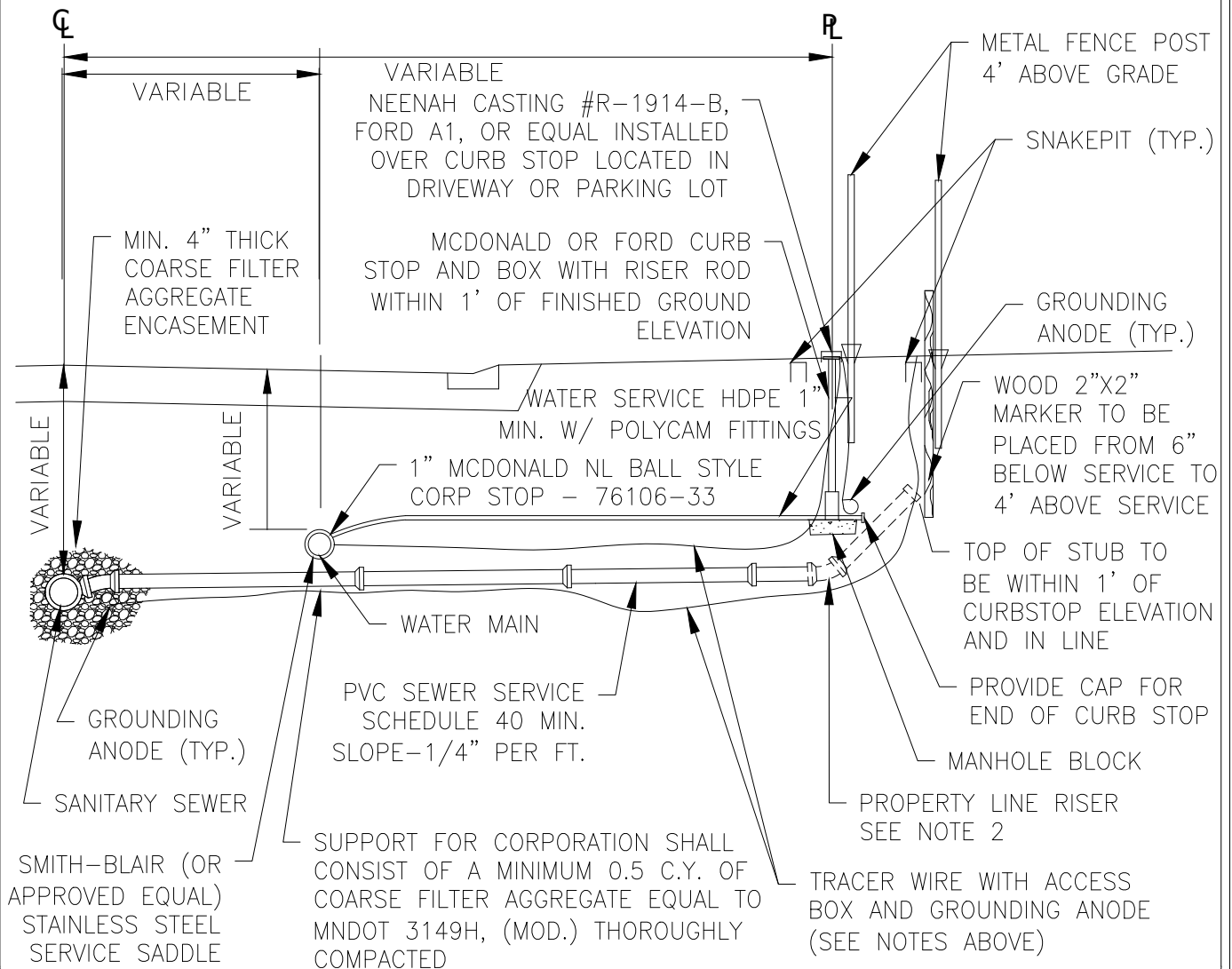

NOTES:

1. ALL NEW CURB BOXES MUST HAVE RISER RODS. WHEN AN EXISTING CURB BOX IS ON A CONSTRUCTION OR RECONSTRUCTION PROJECT, RISER RODS SHALL BE INSTALLED TO ALL CURB BOXES ON THAT PROJECT.
2. INSTALL SERVICE LINES WITH A 45° RISER TO 6' BELOW FINISHED GROUND.
3. PLACEMENT OF CURB STOP AND BOX ON PRIVATE STREETS SHALL BE 9' OUTSIDE OF THE RIGHT OF WAY.
4. TRACER WIRE SHALL BE BROUGHT TO SURFACE ALONG WATERMAIN CURB STOP. INSTALL SNAKEPIT, OR APPROVED EQUAL TRAFFIC RATED TRACER WIRE ACCESS BOX.
5. MIN OF 1 LB. DRIVE IN ANODES WITH MIN 20' WIRE LEAD ARE TO BE INSTALLED AT EVERY TRACER WIRE ACCESS BOX.
6. TRACER WIRE SHALL BE 12 AWG COPPER CLAD STEEL CORE WIRE WITH MIN BREAK LOAD OF 450 LB FOR OPEN CUT INSTALLATION RATED FOR 30 VOLTS. MIN 45 MIL HMWPE JACKET.
7. TRACER WIRE CONNECTOR SHALL BE DRY CONN DIRECT BURY LUG AQUAL, PRO-TRACE DB OR APPROVED EQUAL.
8. WATER SERVICE MUST BE CONTINUOUS WITH NO JOINTS AND STIFFENERS ON ALL FLEXIBLE PLASTIC CONNECTIONS.
9. CONTRACTORS MUST SUPPLY 1 CURBSTOP KEY PER 50 SERVICES OR PHASE, WHICHEVER IS GREATER.

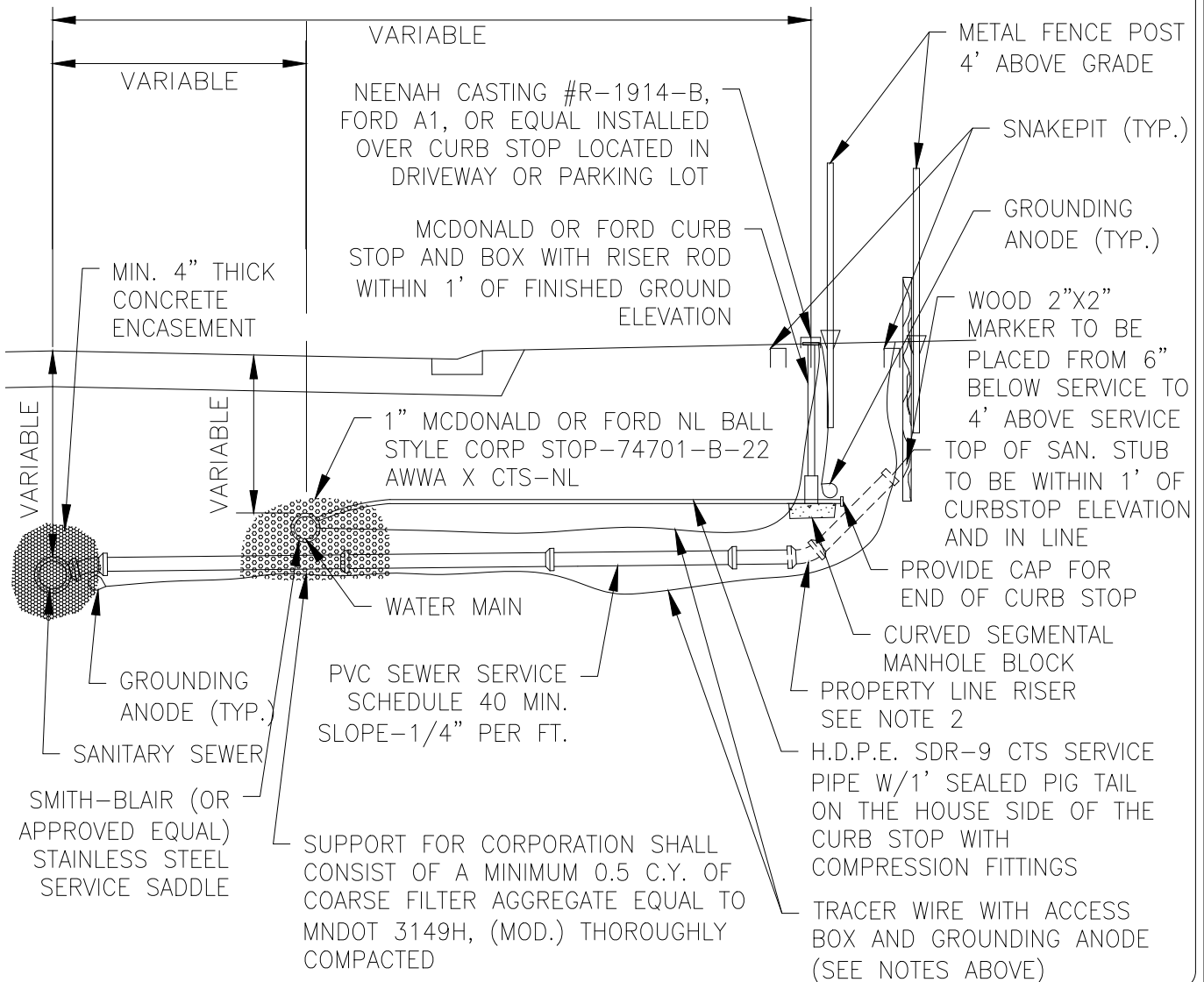

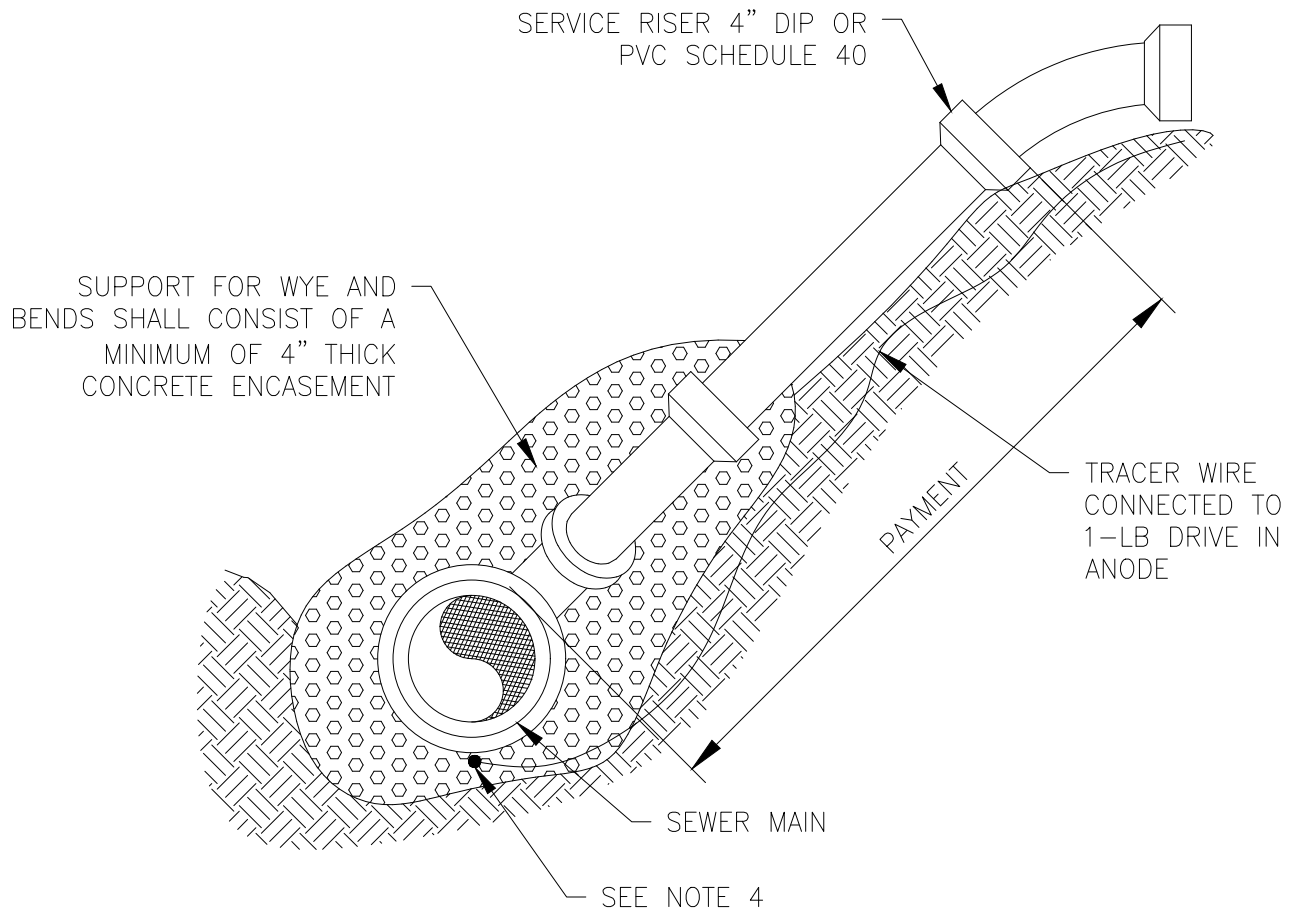

NOTES:

1. WHERE THE SANITARY MAIN IS DEEPER THAN 14.5', SERVICE RISERS SHALL BE REQUIRED.
2. SEE DETAIL SER 1 FOR INFORMATION ON TRACER WIRE AND CONNECTORS.
3. 2' MINIMUM RISER.
4. MIN OF 1 LB. DRIVE IN ANODES WITH 20' WIRE LEAD ARE TO BE INSTALLED AT EVERY SANITARY SERVICE WYE.
5. SEWER DEPTHS OVER 25' AND ALL TRUNK SEWER LINES SHALL USE DUCTILE IRON TEES AND RISERS IN PLACE OF PVC WYES UNLESS OTHERWISE APPROVED BY ENGINEER.
6. WHERE DUCTILE IRON TEE IS USED IN PLACE OF PVC WYE, RISERS TO BE DIP, DIP TO PVC TRANSITION FITTINGS TO BE USED AT TOP OF RISER.
7. ALL SEWER DUCTILE IRON FITTINGS TO BE EPOXY BONDED, ALL SEWER DUCTILE IRON PIPES AND FITTINGS TO HAVE PROTECTO 401 LINER. ALL MATERIALS TO BE AMERICAN MADE.
8. ALL DUCTILE IRON PIPES AND FITTINGS TO BE WRAPPED IN POLY AND TAPED.



2026 DETAIL PLATES
REV.1

SERVICE RISER

LAST REVISION:
OCT 2024

PLATE NO.
SER-02

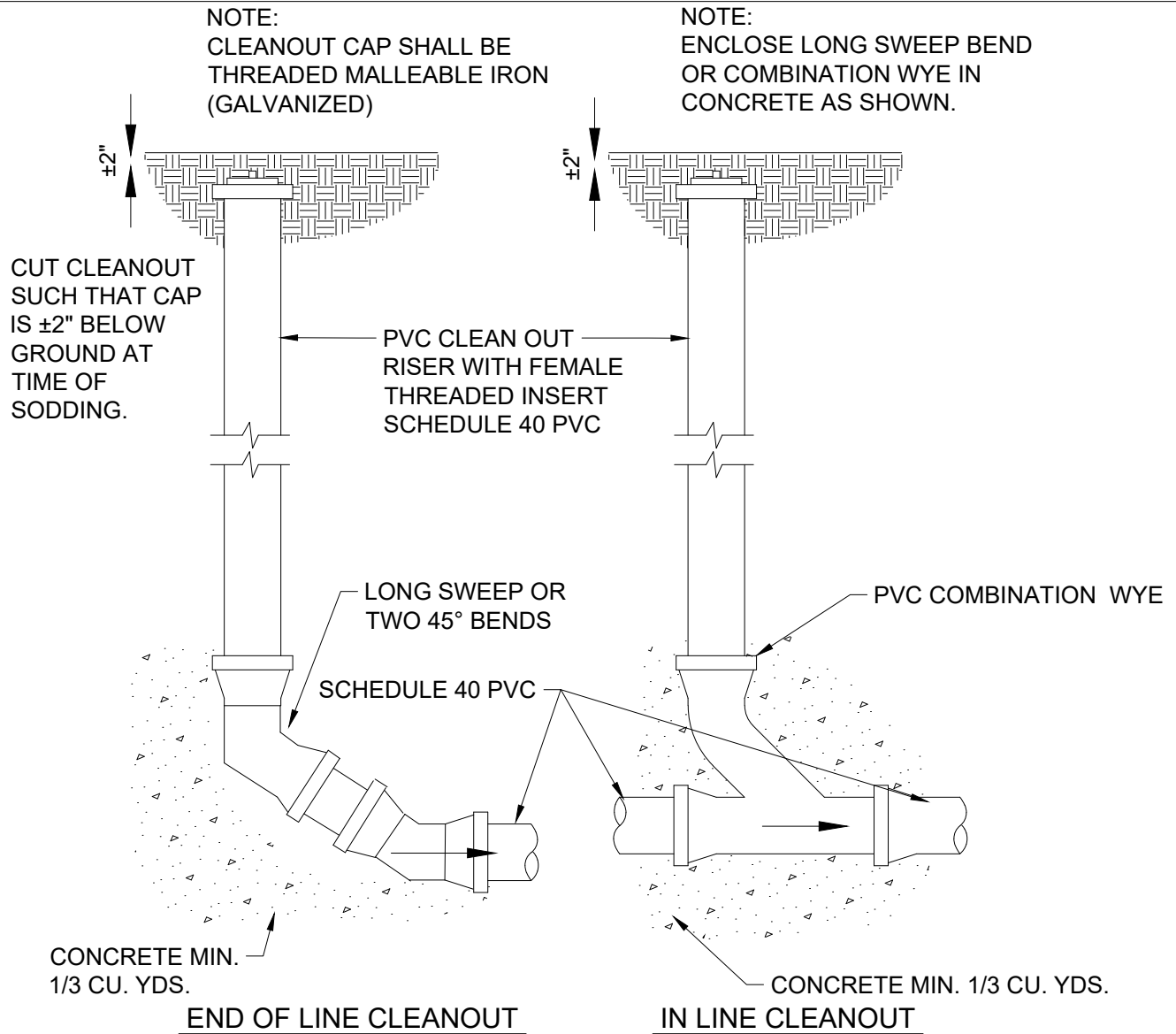

NOTE:

1. CLEANOUT IS REQUIRED FOR EVERY 100 FEET OF SERVICE LENGTH, OR AT BENDS IN SERVICE.
2. IF CLEANOUT IS IN DRIVEWAY, CONTRACTOR MUST INSTALL FORD A-1 CASTING, MARKED WITH "SEWER ON LID.
3. IF CLEANOUT IS IN ROADWAY, CONTRACTOR MUST INSTALL TOP SECTION OF A VALVE BOX WITH LID MARKED "SEWER".
4. CLEANOUT CAPS SHALL BE GALVANIZED, THREADED MALLEABLE IRON.
5. ENCLOSE LONG SWEEP BEND OR COMBINATION WYE IN CONCRETE AS SHOWN ABOVE.
6. THE CONTRACTOR IS RESPONSIBLE FOR TELEVISIONING DRAINTILE AFTER THE INSTALLATION OF SMALL UTILITIES.
7. TELEVISIONING VIDEO AND REPORT TO BE SUBMIT TO THE ENGINEER VIA EMAIL AND HARD COPY. NOTIFY ENGINEER WHEN TELEVISIONING.

PERMITS REQUIRED

- ① ABANDON SEPTIC TANK -SEE PROCEDURES BELOW
- ② CONNECTION FROM THE BUILDING TO STUB- LICENSED PIPE LAYER REQUIRED
- ③ NEW INTERNAL PLUMBING - LICENSED MASTER PLUMBER REQUIRED
- ④ ABANDON WELL - HENNEPIN COUNTY (SEE ATTACHED INFORMATION)

REPLUMBING REQUIRED INTERNALLY

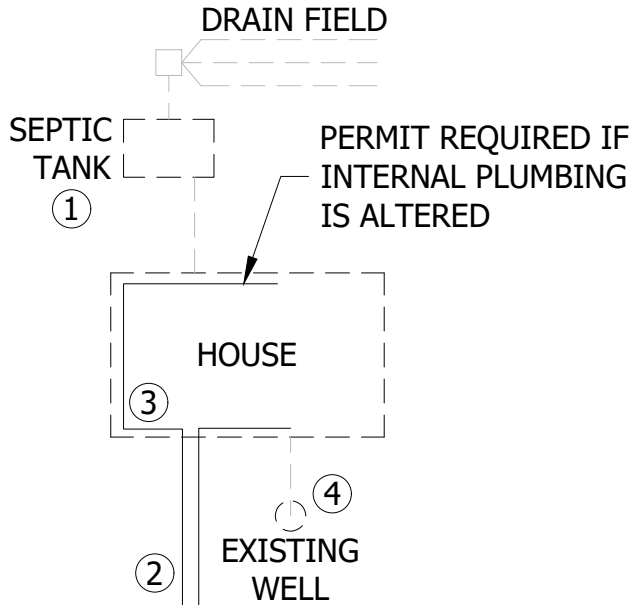

NO REPLUMBING REQUIRED INTERNALLY

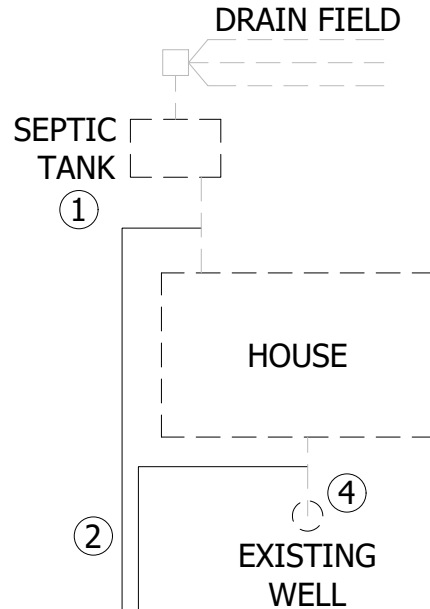

EXISTING WATER MAIN
EXISTING SANITARY SEWER

EXISTING SEWER/WATER SERVICE STUBS

NOTES

1. CURB BOX SHALL NOT BE LOCATED IN DRIVEWAY.
2. ALL SYSTEMS WITH NO FUTURE INTENT FOR USE MUST BE ABANDONED. ALL SOLIDS AND LIQUIDS MUST BE DISPOSED OF ACCORDINGLY BY A LICENSED MAINTENANCE BUSINESS. ALL ELECTRICAL DEVICES AND DEVICES CONTAINING MERCURY MUST BE REMOVED AND DISPOSED OF ACCORDING TO APPLICABLE REGULATIONS. ABANDONED TANKS OR ANY OTHER UNDERGROUND CAVITIES MUST BE REMOVED OR REMAIN IN PLACE AND CRUSHED WITH THE REMAINING CAVITY FILLED WITH SOIL OR ROCK MATERIAL. ACCESS FOR FUTURE DISCHARGE TO THE SYSTEM MUST BE PERMANENTLY DENIED.
3. SANITARY SEWER SERVICE SHALL BE 4" PVC SCHEDULE 40.
4. WATER SERVICE SHALL BE INSTALLED WITH TRACER WIRE.
5. COMPLY WITH MINNESOTA DEPARTMENT OF HEALTH SEPARATION REQUIREMENTS.

PERMITS REQUIRED

- ① ABANDON SEPTIC TANK -SEE PROCEDURES BELOW
- ② CONNECTION FROM THE BUILDING TO STUB- LICENSED PIPE LAYER REQUIRED
- ③ NEW INTERNAL PLUMBING - LICENSED MASTER PLUMBER REQUIRED
- ④ ABANDON WELL - HENNEPIN COUNTY (SEE ATTACHED INFORMATION)

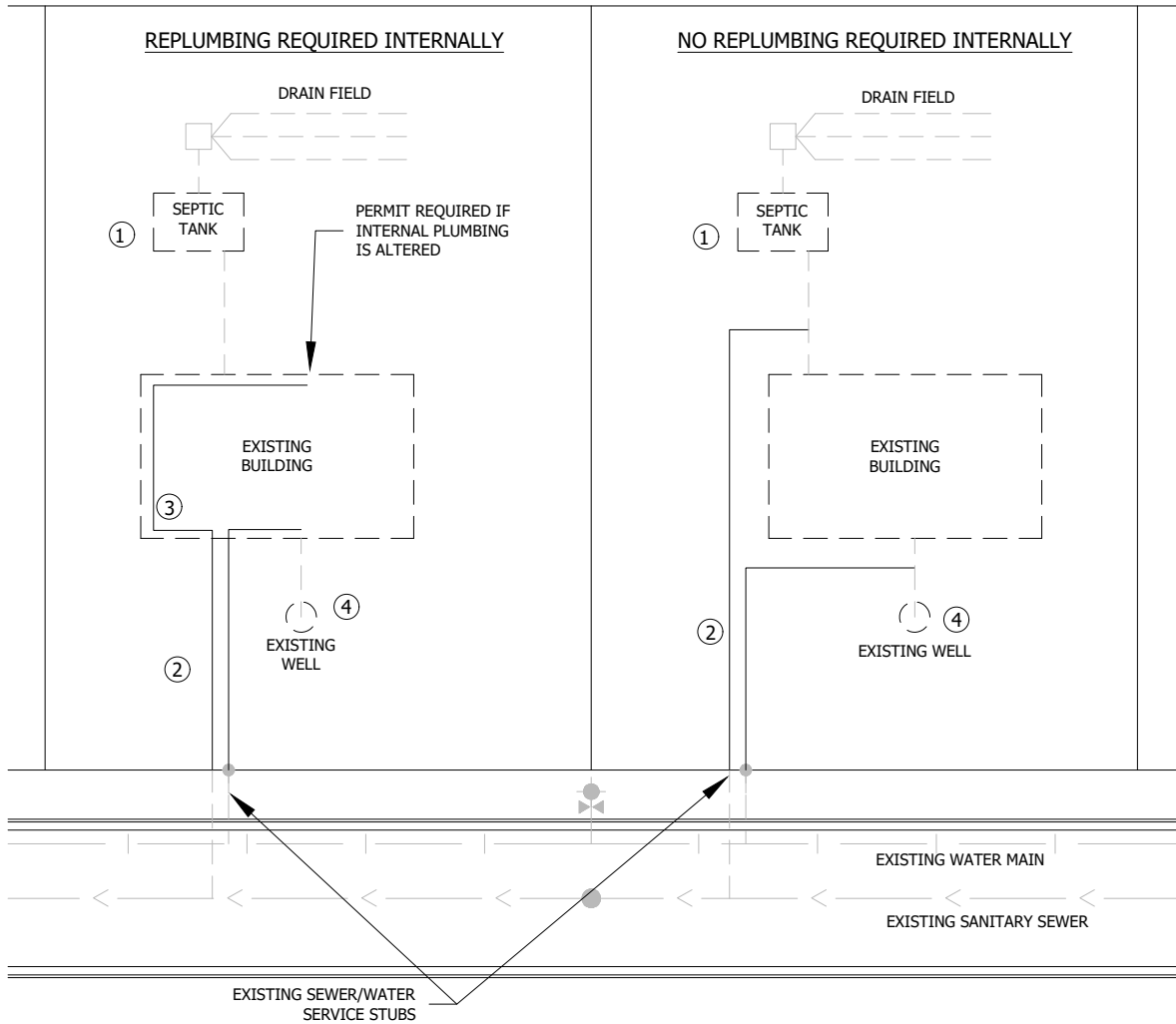

NOTES

1. GATE VALVE SHALL NOT BE LOCATED IN DRIVEWAY.
2. ALL SYSTEMS WITH NO FUTURE INTENT FOR USE MUST BE ABANDONED. ALL SOLIDS AND LIQUIDS MUST BE DISPOSED OF ACCORDINGLY BY A LICENSED MAINTENANCE BUSINESS. ALL ELECTRICAL DEVICES AND DEVICES CONTAINING MERCURY MUST BE REMOVED AND DISPOSED OF ACCORDING TO APPLICABLE REGULATIONS. ABANDONED TANKS OR ANY OTHER UNDERGROUND CAVITIES MUST BE REMOVED OR REMAIN IN PLACE AND CRUSHED WITH THE REMAINING CAVITY FILLED WITH SOIL OR ROCK MATERIAL. ACCESS FOR FUTURE DISCHARGE TO THE SYSTEM MUST BE PERMANENTLY DENIED.
3. SANITARY SEWER SERVICE SIZE SHALL BE BASED ON FLOW USAGE
4. WATER SERVICE SIZE SHALL BE BASED ON USAGE/FIRE PROTECTION.
5. WATER SERVICE SHALL BE INSTALLED WITH TRACER WIRE.
6. COMPLY WITH MINNESOTA DEPARTMENT OF HEALTH SEPARATION REQUIREMENTS.

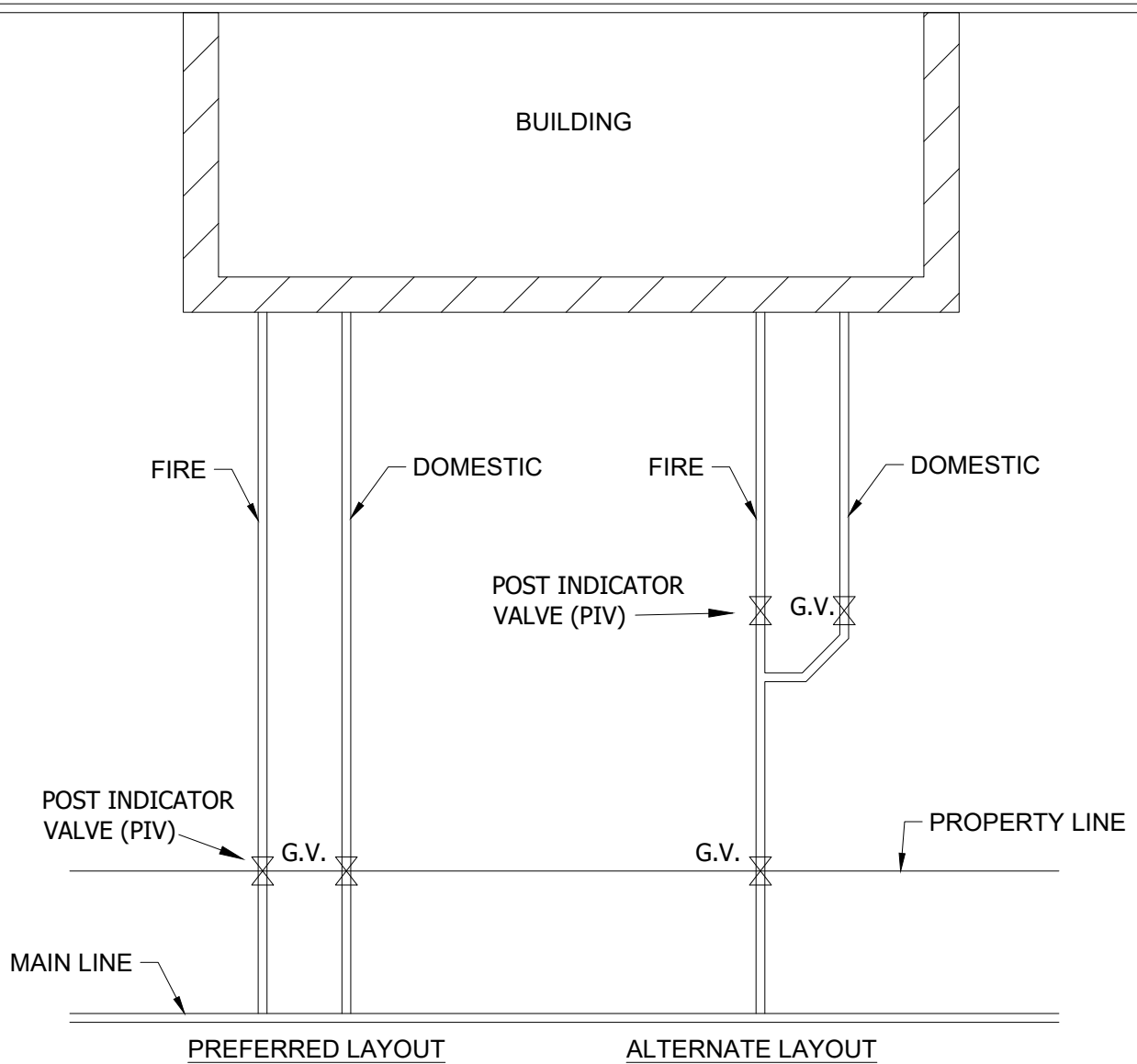

NOTE:

1. PREFERRED LAYOUT TO BE USED EXCEPT WHEN THERE IS ONLY ONE EXISTING SERVICE IS AVAILABLE.
3. SEE DETAIL PLATE WAT-02 FOR INFORMATION ON GATE VALVE INSTALLATION.
4. ALL VALVES TO HAVE 3' OF PIPE MINIMUM BETWEEN TEES, CROSSES, & HYDRANTS.
5. ALL DUCTILE IRON WATERMAIN FITTINGS SHALL BE FUSION BONDED EPOXY COATED, POLYWRAPPED, AND TAPED.

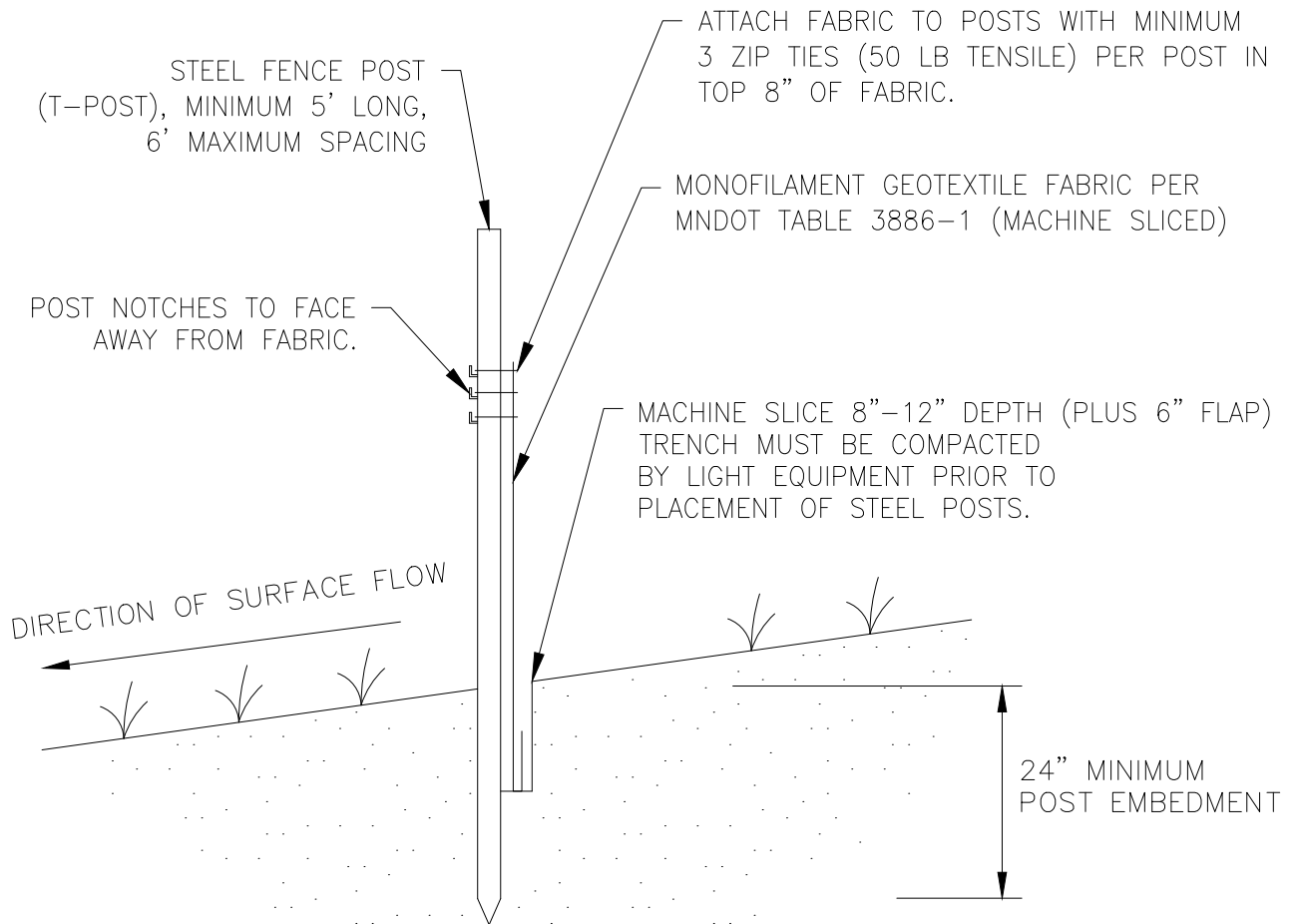

NOTE:
 THE MACHINE SLICED METHOD (THIS DETAIL) IS THE STANDARD SILT FENCE INSTALLATION METHOD. HEAVY-DUTY (ERO-1B) OR STANDARD (ERO-1C) SILT FENCE INSTALLATION METHODS SHOULD ONLY BE USED WHEN APPROVED OR DIRECTED BY THE CITY.

STEEL FENCE POST (T-POST), MINIMUM 5' LONG, 6' MAXIMUM SPACING

WIRE MESH REINFORCEMENT, STD. FIELD FENCE, MIN. 30" HIGH, MAX. MESH SPACING 6" AND 1 MIN 14/GAUGE WIRE.

ATTACH FABRIC TO POSTS WITH MINIMUM 3 ZIP TIES (50 LB TENSILE) PER POST IN TOP 8" OF FABRIC.

GEOTEXTILE FABRIC PER MNDOT TABLE 3886-1 (HEAVY DUTY) OVERLAP TOP 6" OF FABRIC AND FASTED TO WIRE MESH AT 2' INTERVALS WITH RINGS OR WIRE TIES.

POST NOTCHES TO FACE AWAY FROM FABRIC.

ATTACH WIRE MESH TO POSTS WITH MINIMUM 3 U-SHAPED WIRE FASTENERS PER POST.

LAY FABRIC/WIRE MESH IN THE TRENCH, BACKFILL WITH NATURAL SOIL, AND COMPACT WITH LIGHT EQUIPMENT PRIOR TO PLACEMENT OF THE POSTS.

DIRECTION OF SURFACE FLOW

24" MINIMUM POST EMBEDMENT

EXTEND WIRE MESH INTO TRENCH.

6"

6"

STEEL FENCE POST (T-POST), MINIMUM 5' LONG, 6' MAXIMUM SPACING

MONOFILAMENT GEOTEXTILE FABRIC PER MNDOT TABLE 3886-1 (MACHINE SLICED)

ATTACH FABRIC TO POSTS WITH MINIMUM 3 ZIP TIES (50 LB TENSILE) PER POST IN TOP 8" OF FABRIC.

POST NOTCHES TO FACE AWAY FROM FABRIC.

LAY FABRIC IN THE TRENCH, BACKFILL WITH NATURAL SOIL, AND COMPACT WITH LIGHT EQUIPMENT PRIOR TO PLACEMENT OF THE POSTS.

DIRECTION OF SURFACE FLOW

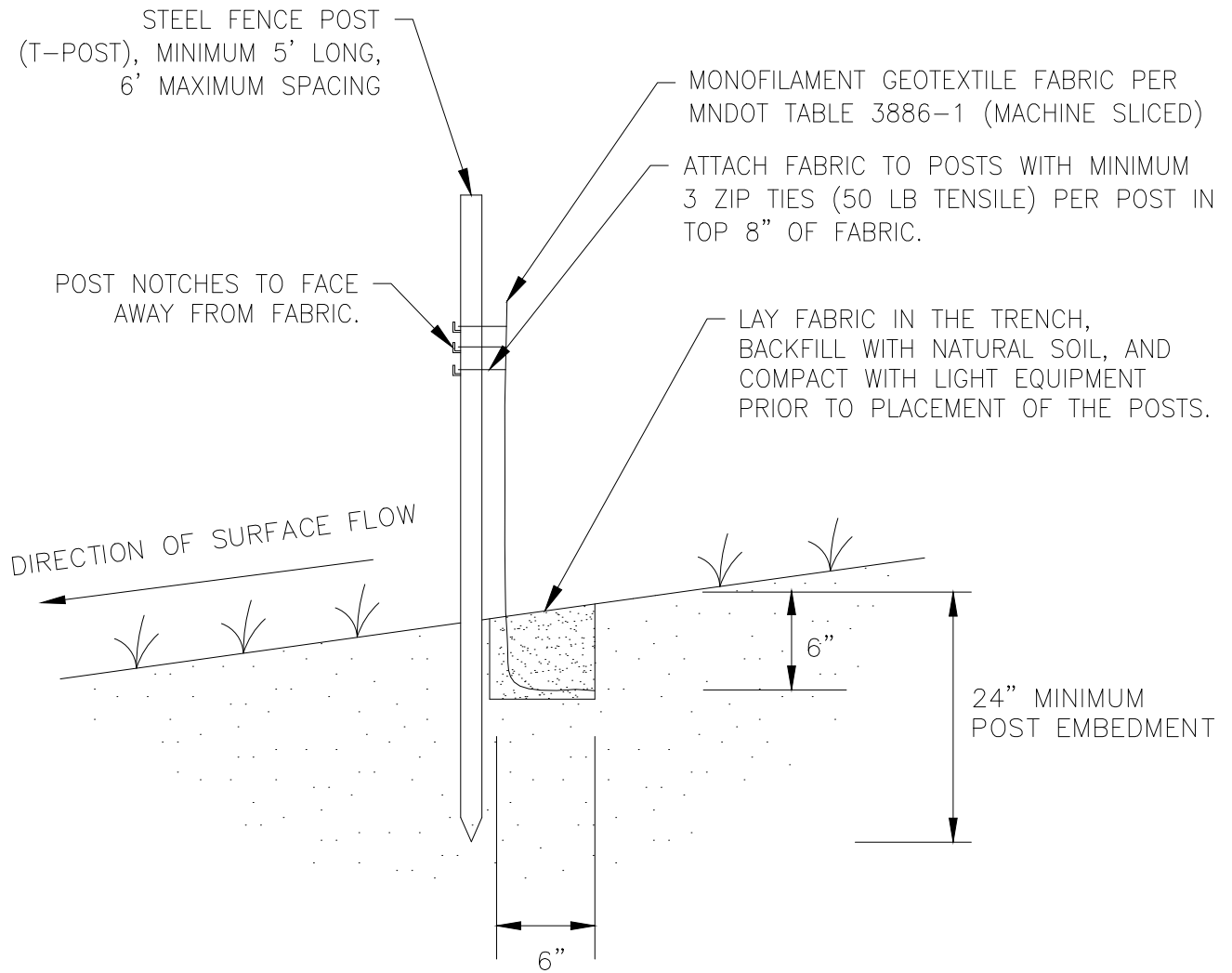

2026 DETAIL PLATES
REV.1

SILT FENCE STANDARD

LAST REVISION:
OCT 2024

PLATE NO.
ERO-01C

PLAN VIEW

I. SPACING REQUIREMENTS

DIRECTION OF SURFACE FLOW

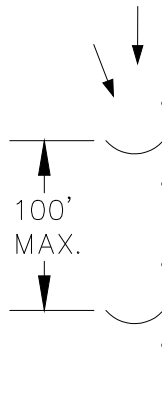

NOTE: SPACING DISTANCES WILL VARY, BUT ARE NOT TO EXCEED 100 FEET.

II. SIZING REQUIREMENTS: J15, J25

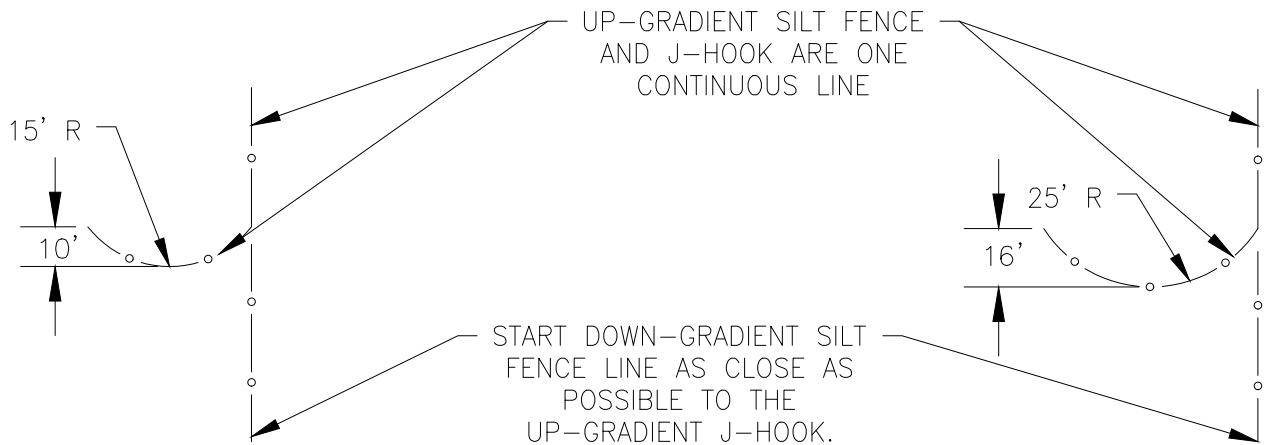

J15 - FOR CATCHMENT AREA < 0.25 ACRES

J25 - FOR CATCHMENT AREA ≥ 0.25 ACRES

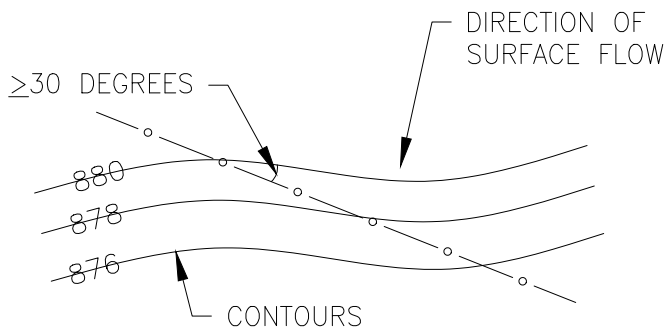

NOTE: J-HOOKS SHALL BE USED WHEN THE SILT FENCE IS INSTALLED AT AN ANGLE OF 30 DEGREES OR GREATER FROM PARALLEL TO THE CONTOURS.

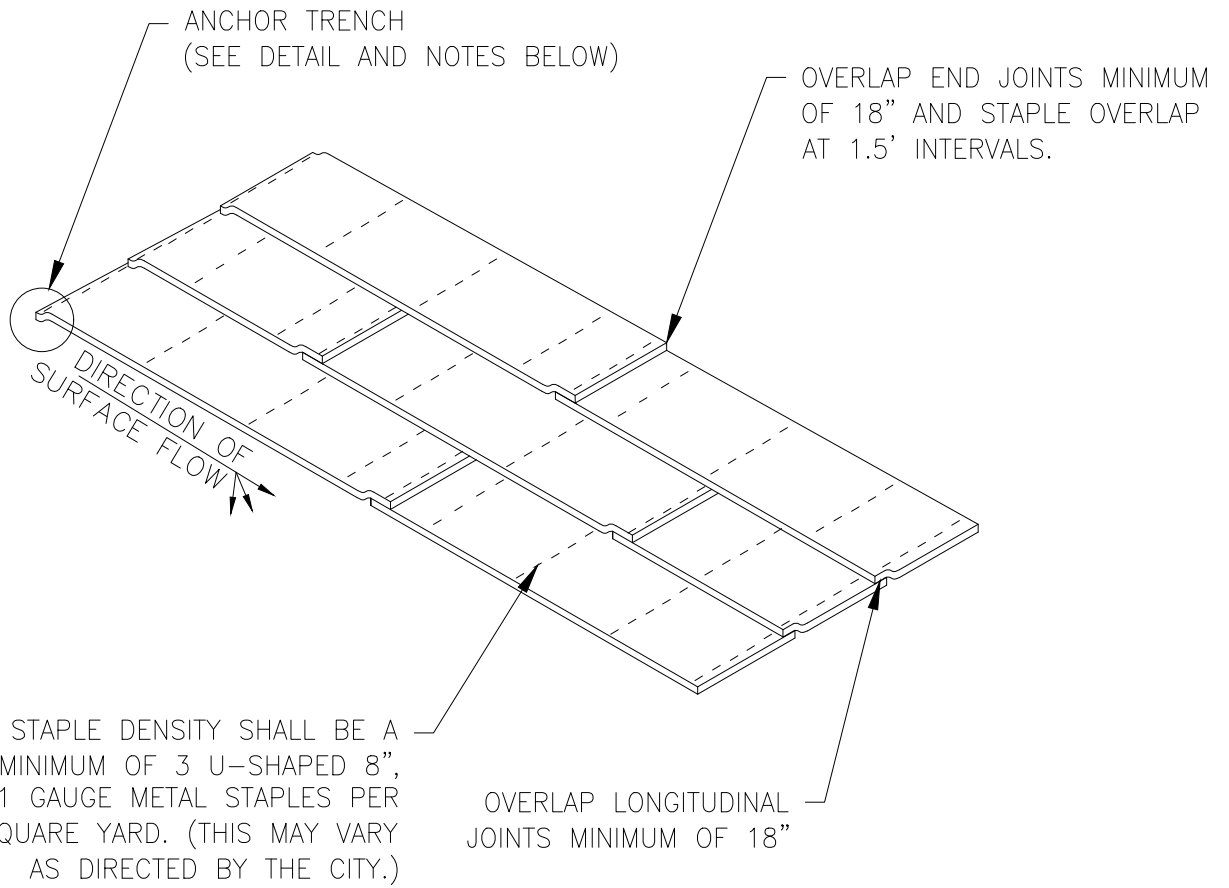

ANCHOR TRENCH

1. DIG 6" X 6" TRENCH
2. LAY BLANKET IN TRENCH
3. STAPLE AT 1.5' INTERVALS
4. BACKFILL WITH NATURAL SOIL AND COMPACT

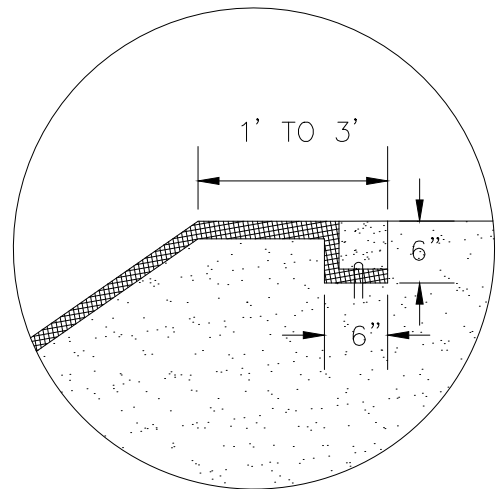

2026 DETAIL PLATES
REV.1

EROSION CONTROL BLANKET
INSTALLATION

LAST REVISION:
DEC 2025

PLATE NO.
ER0-02

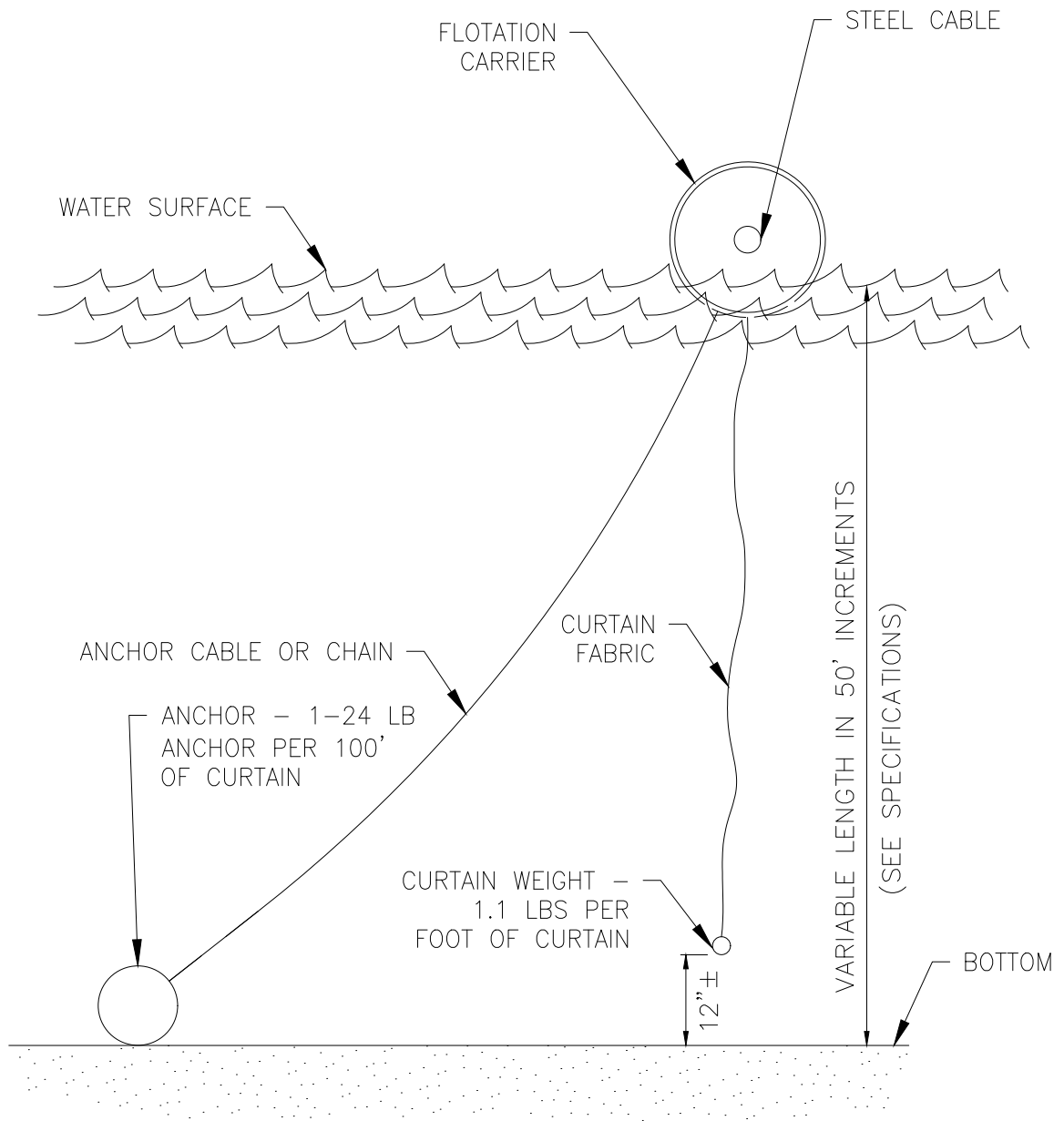

NOTE: DOUBLE SILT CURTAINS SHOULD BE SPACED 10' APART.



2026 DETAIL PLATES
REV.1

FLOATING SILT CURTAIN

LAST REVISION:
OCT 2024

PLATE NO.
ERO-03

WOODEN LATH SHALL BE NAILED SECURELY TO THE POST MEMBER TO SECURE FILTER FABRIC.

2" X 4" X 2.5' LONG WOOD POSTS, 8 REQ'D

2" X 4" HORIZONTAL MEMBERS CONTINUOUS AROUND TOP AND BOTTOM FASTENED TO EACH POST USING 2-20D COMMON NAILS

MONOFILAMENT GEOTEXTILE (SILT FENCE) FABRIC, AS SPECIFIED. ADDITIONAL 8"-10" OF FABRIC FLAP AT BOTTOM OF BOX

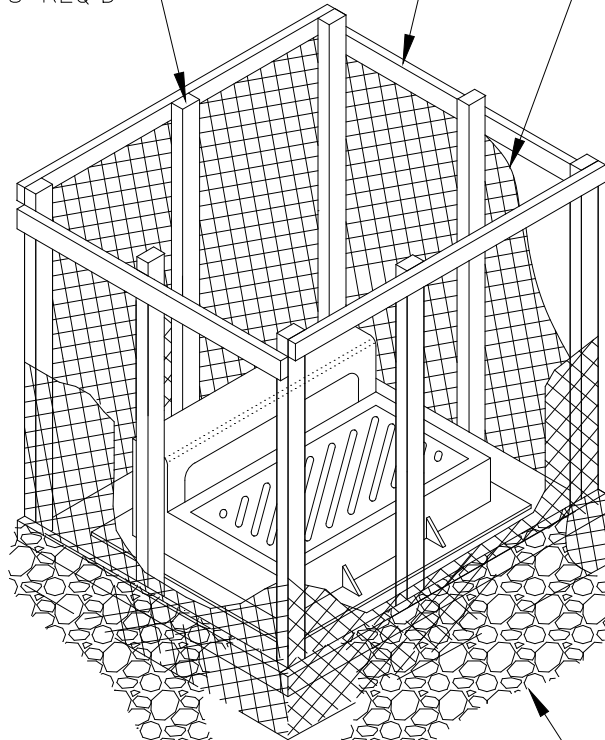

2'-6"

8-10" FABRIC FLAP EXTENDING BEYOND BOTTOM 2"X4" - BURY UNDER ROCK TO PREVENT UNDERWASHING

1 1/2" WASHED ROCK
1' DEEP X 1' WIDE

NOTES:

CONTRACTOR SHALL CONSTRUCT SILT BOX TO FIT AROUND THE INLET STRUCTURE WITH 6" MINIMUM CLEARANCE TO EDGES OF STRUCTURE. SILT BOX TO BE PLACED ON AN EVEN SURFACE 6" BELOW STRUCTURE OPENING. TOP OF SILT BOX TO EXTEND 18" MINIMUM ABOVE EXISTING GRADE.

PLAN

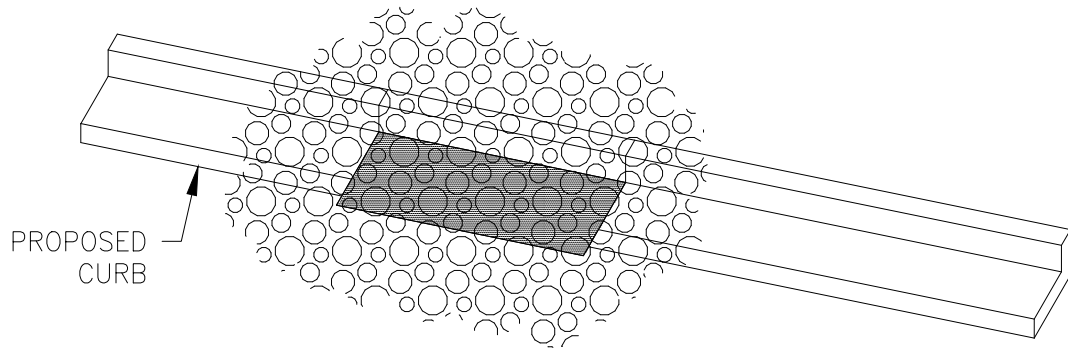

←← DIRECTION OF SURFACE FLOW

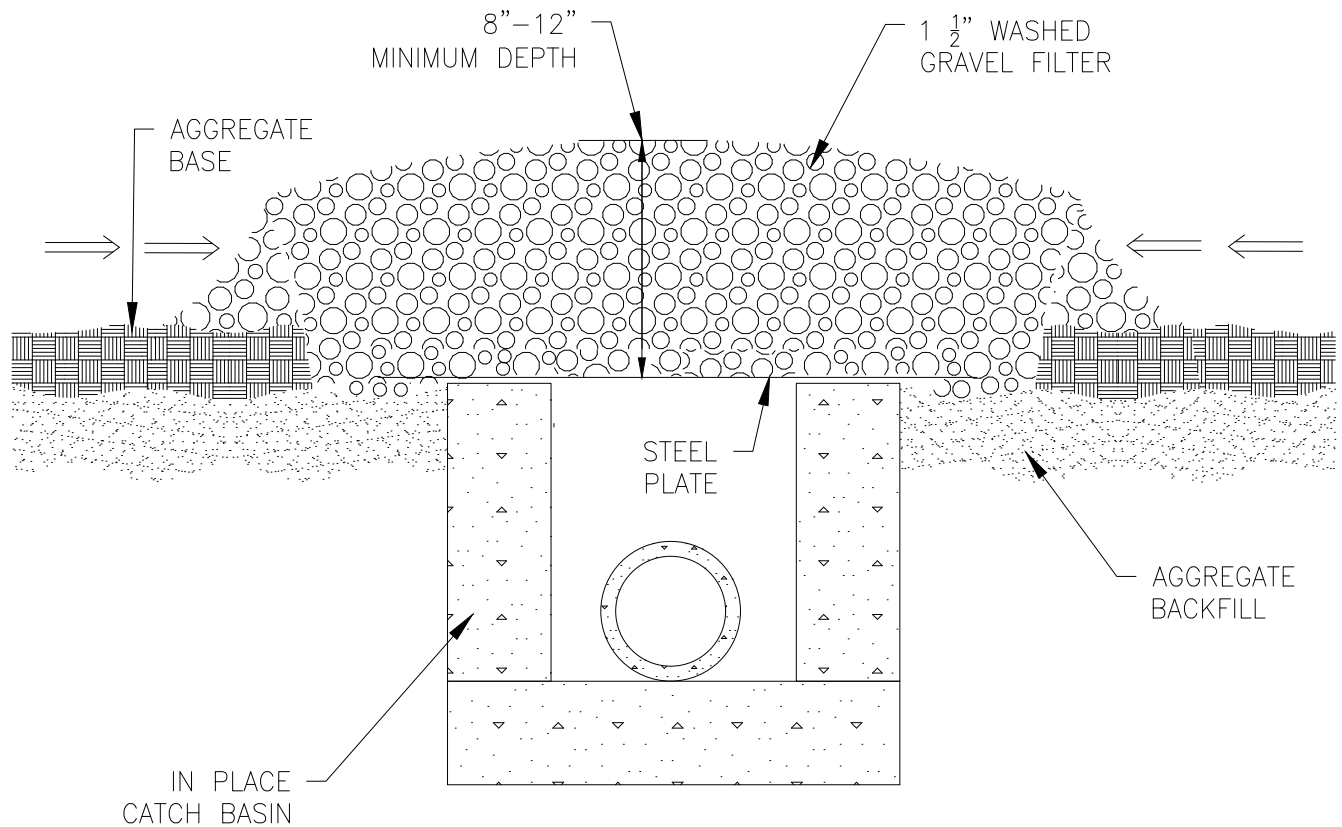

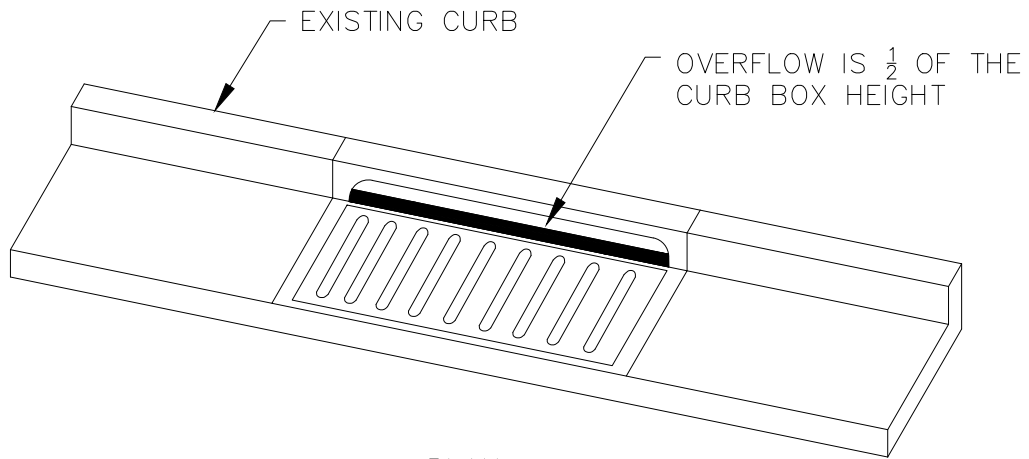

PLAN

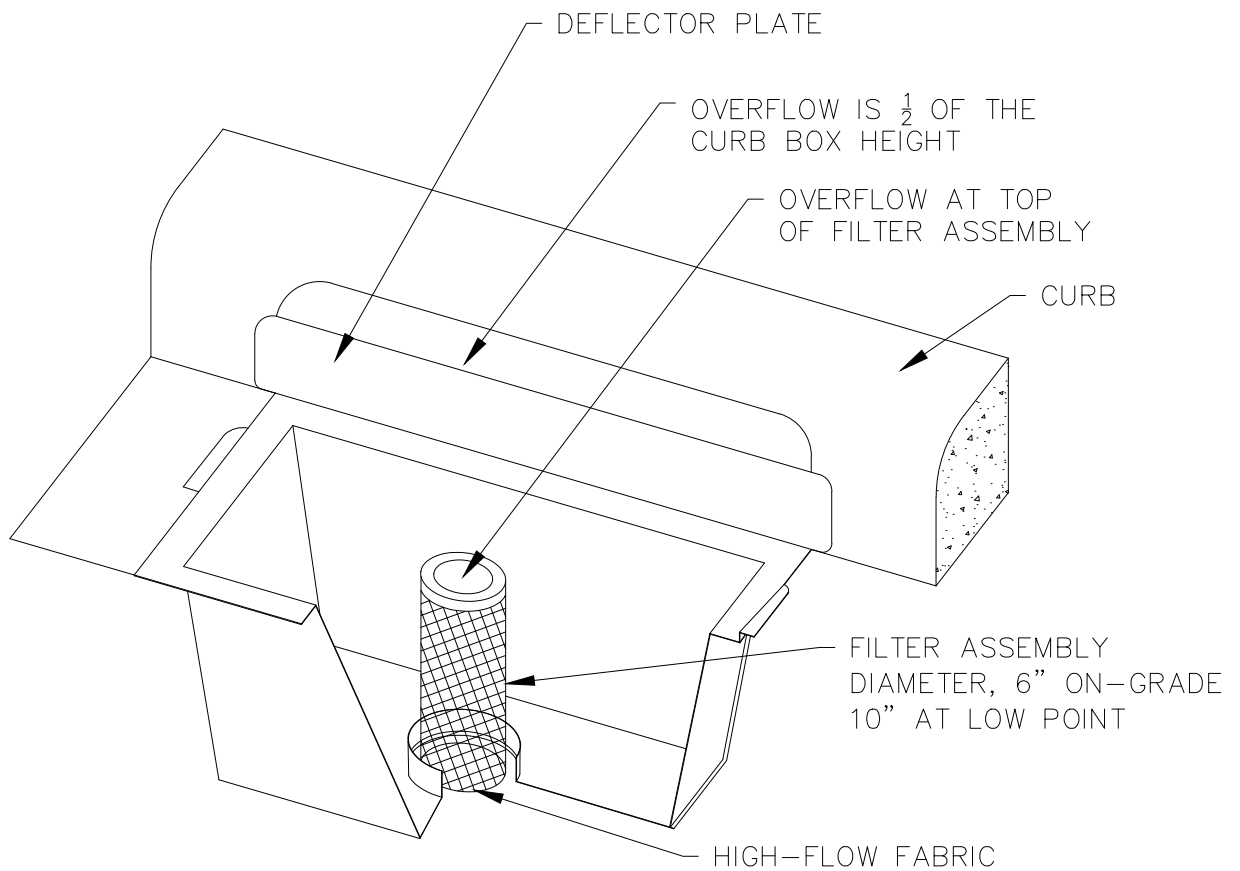

WIMCO ROAD DRAIN CG-3067 HIGH FLOW
 INLET PROTECTION CURB AND GUTTER
 MODEL OR CITY-APPROVED EQUAL.



2026 DETAIL PLATES
 REV.1

**INLET PROTECTION
 CATCH BASIN INSERT
 AFTER PAVING**

LAST REVISION:
OCT 2024

PLATE NO.
ERO-04C

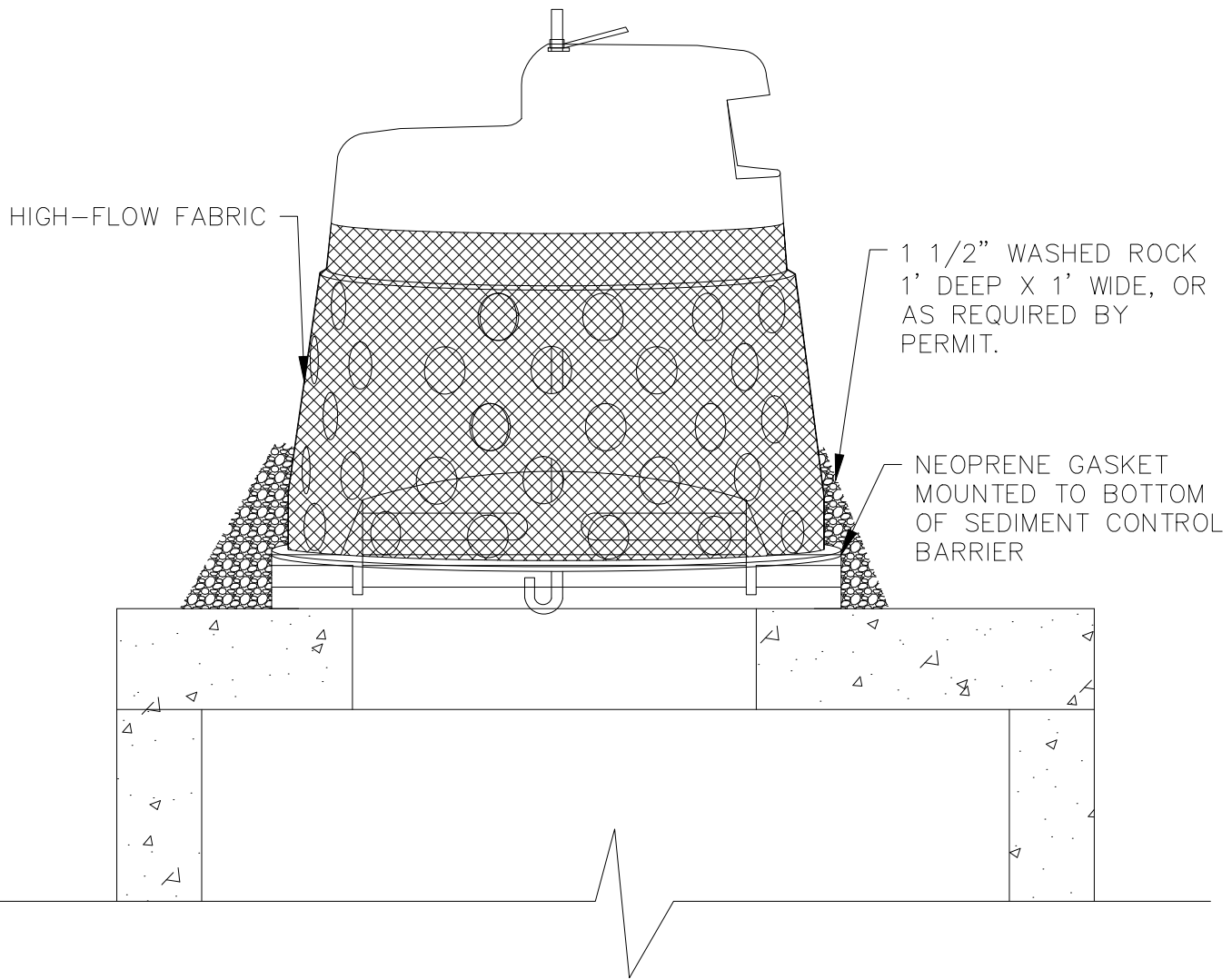

NOTES:

INFRA SAFE SEDIMENT CONTROL BARRIER OR CITY-APPROVED EQUAL



2026 DETAIL PLATES
REV.1

INLET PROTECTION
SILT BOX FOR BEEHIVE CASTING

LAST REVISION:
OCT 2024

PLATE NO.
ERO-04D

6" X 6" TRENCH WITH LEADING EDGE
OF TYPE IV GEOTEXTILE FABRIC
STAPLED AT 4' INTERVALS AND
BACKFILLED WITH NATURAL SOIL

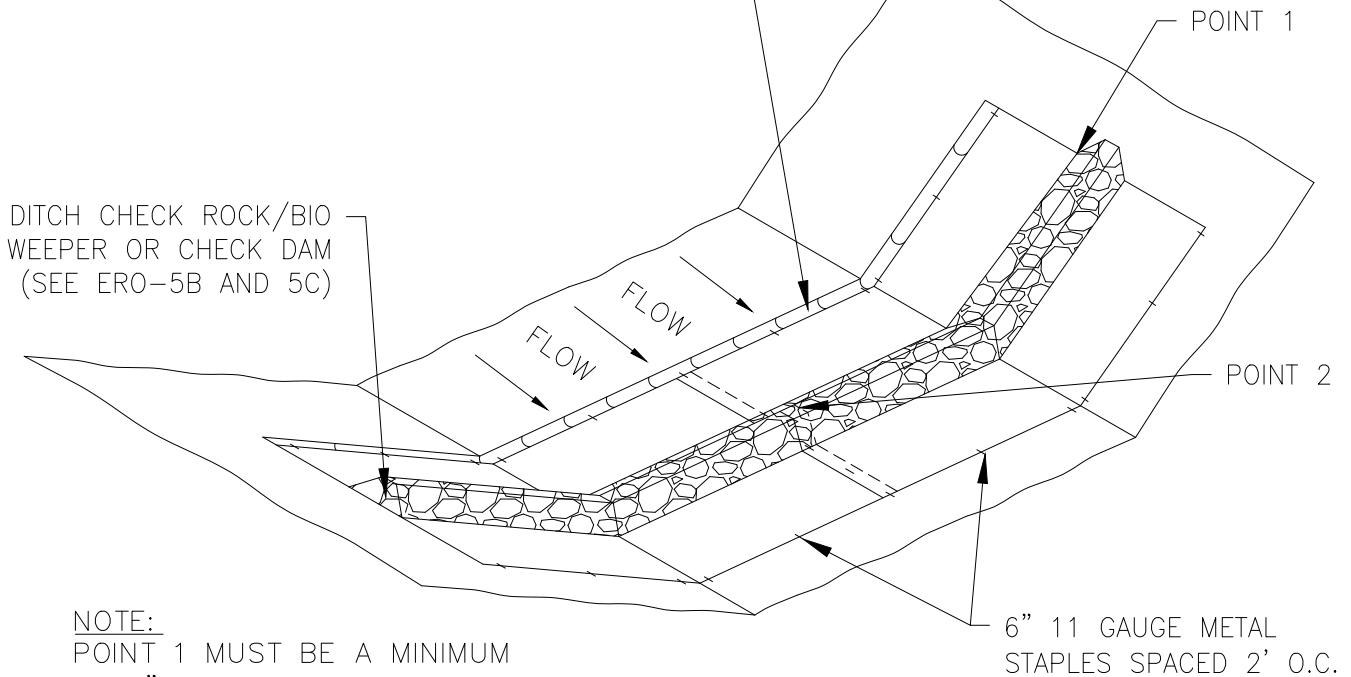

NOTE:
POINT 1 MUST BE A MINIMUM
OF 6" HIGHER THAN POINT 2
TO ENSURE THAT WATER
FLOWS OVER THE DITCH
CHECK AND NOT AROUND
THE ENDS.

6" 11 GAUGE METAL
STAPLES SPACED 2' O.C.

DITCH CHECK SPACING
(USE FOR DETAILS ERO-5B, 5C, 5D,
AND 5E)

DITCH GRADE	INTERVAL
(%)	(FT)
2	100
4	75
6	50
8	40
10	25
10+	25

I. ROCK WEEPER

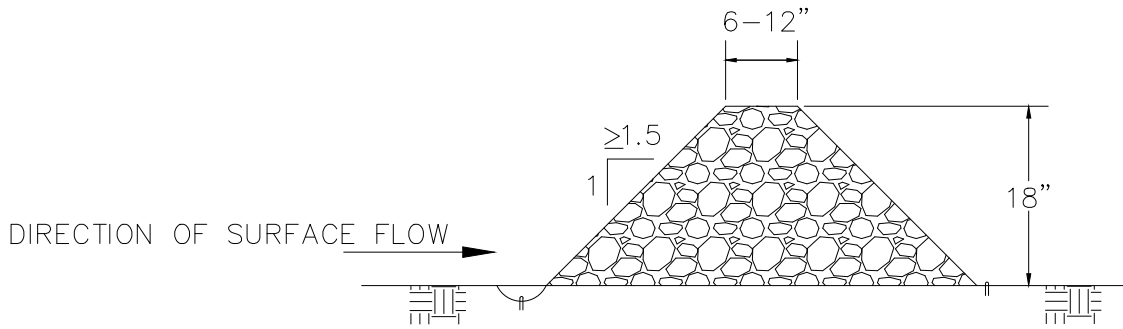

II. BIO WEEPER

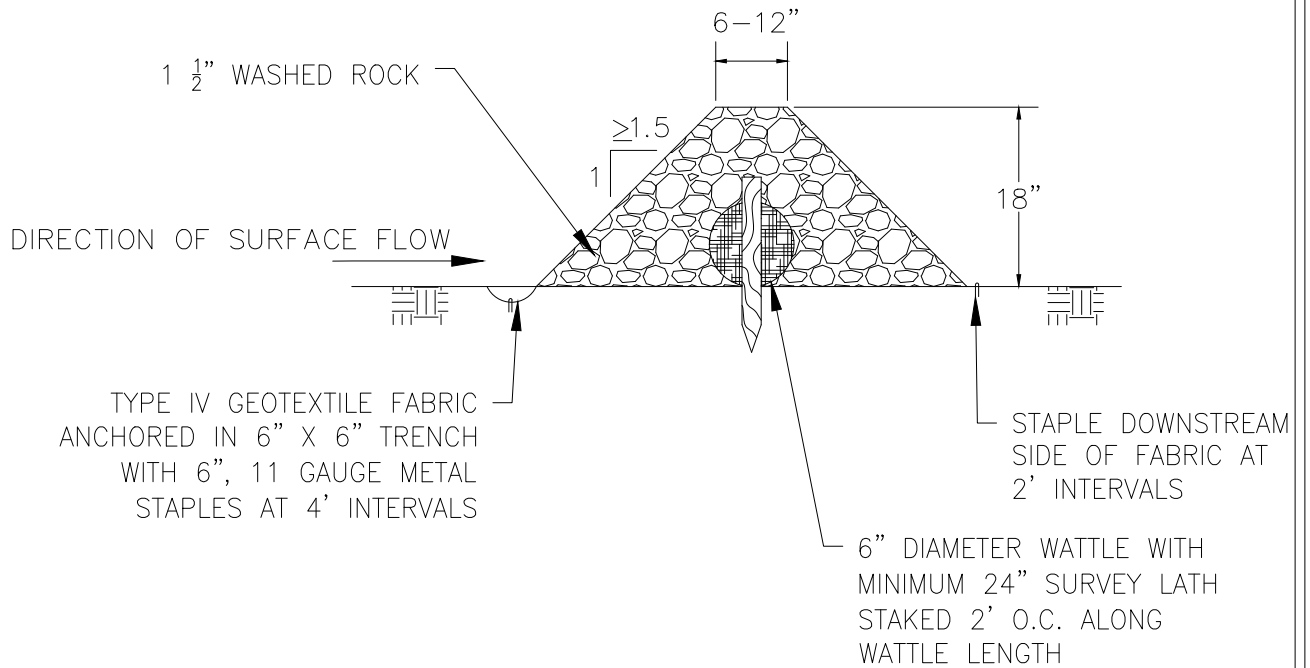

I. SMALL CHECK DAM

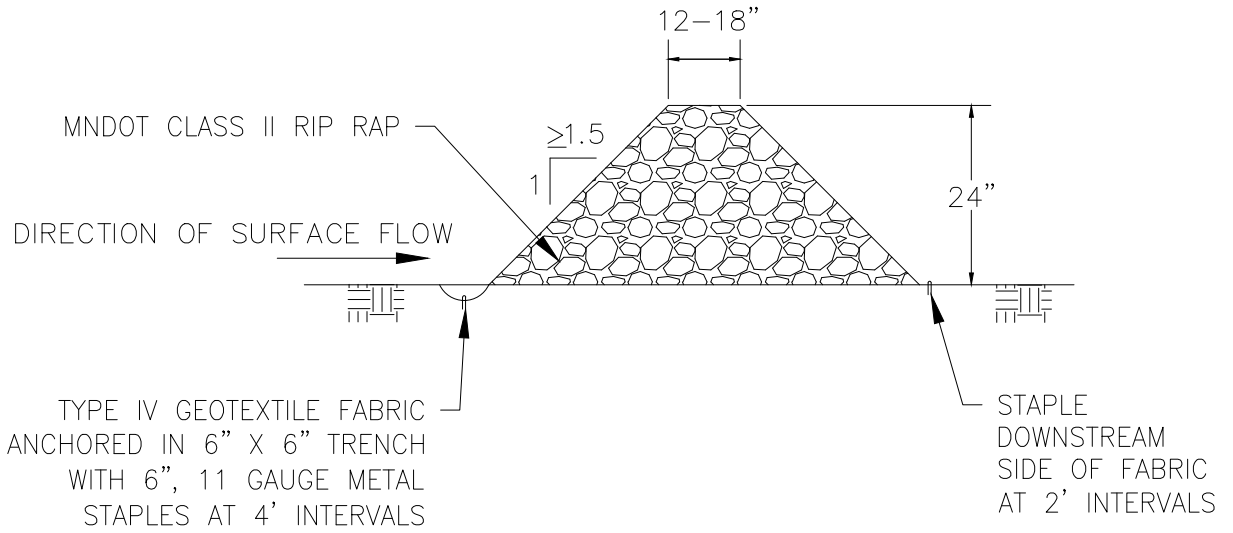

II. LARGE CHECK DAM

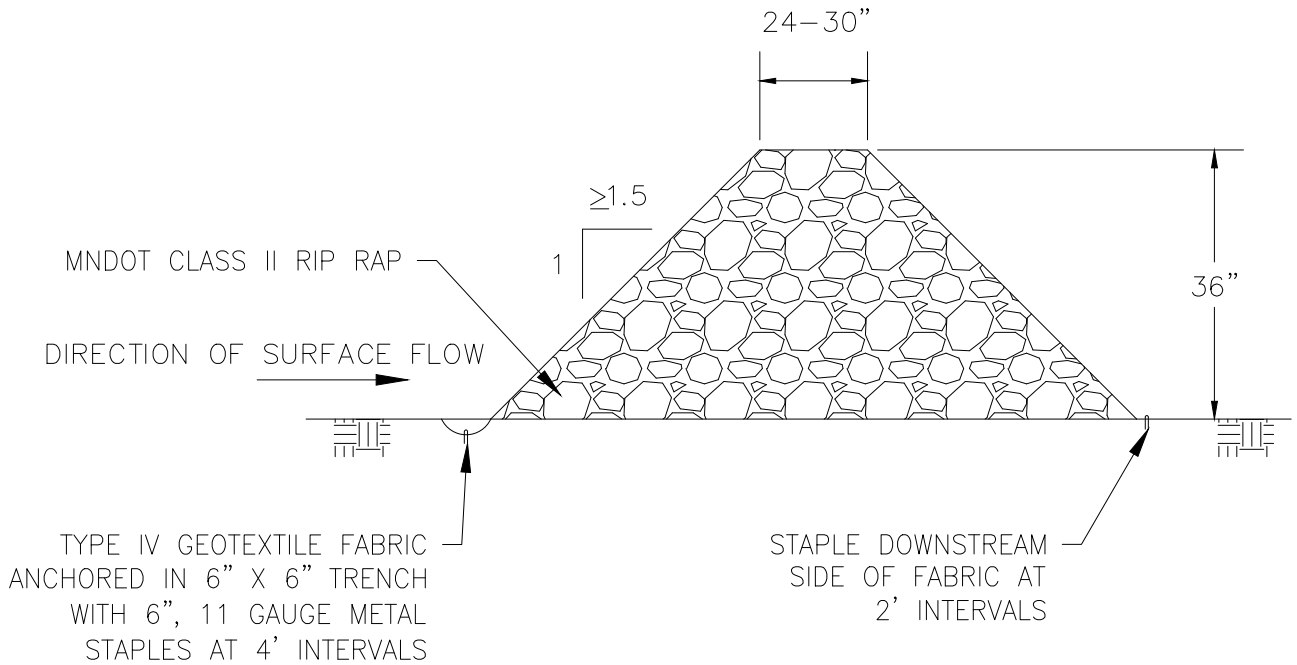

NOTE:
 POINT 1 MUST BE A MINIMUM 6"
 HIGHER THAN POINT 2 TO ENSURE
 THAT WATER FLOWS OVER THE SILT
 FENCE AND NOT AROUND THE ENDS.

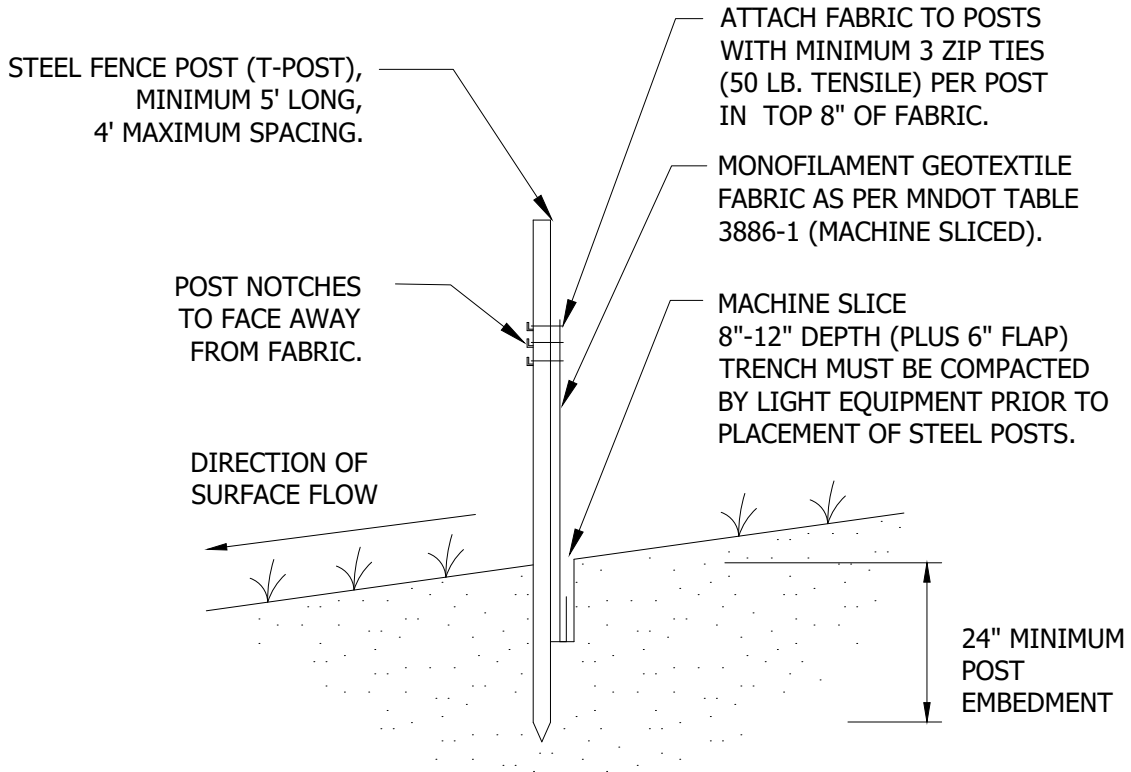
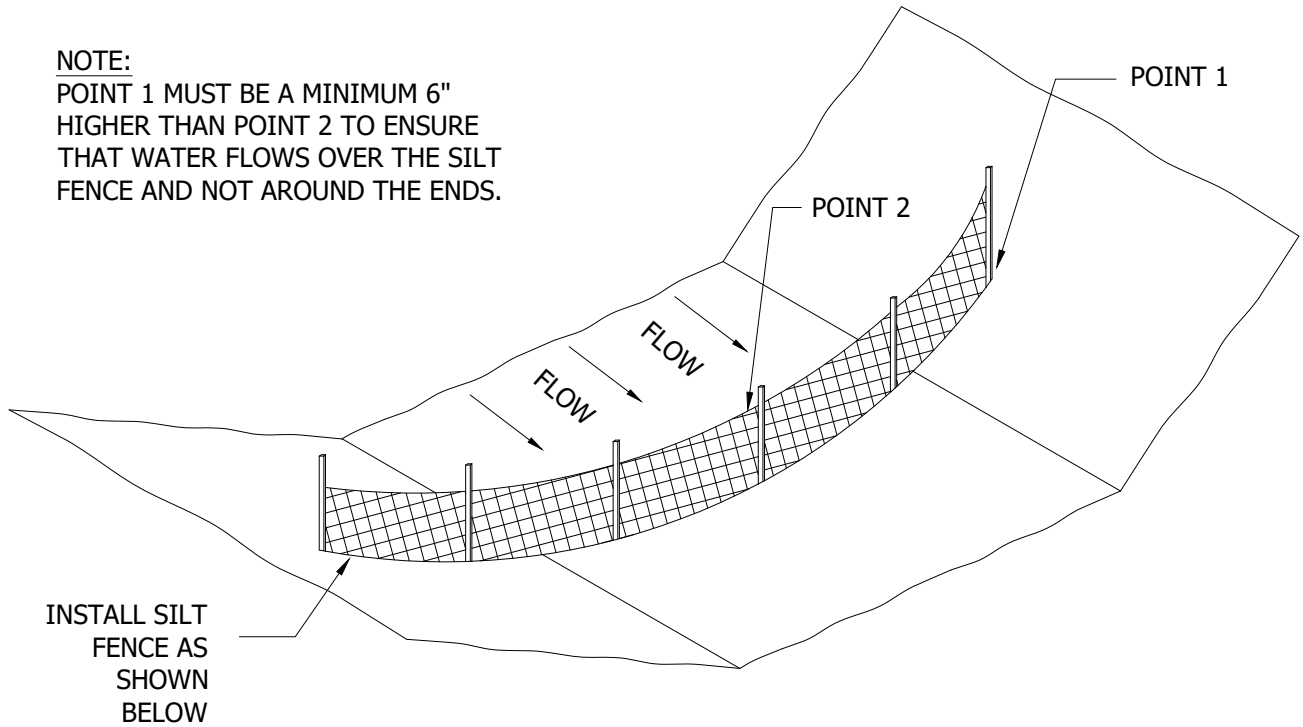

NOTE:
POINT 1 MUST BE A MINIMUM OF 6"
HIGHER THAN POINT 2 TO ENSURE
THAT WATER FLOWS OVER THE DIKE
AND NOT AROUND THE ENDS.

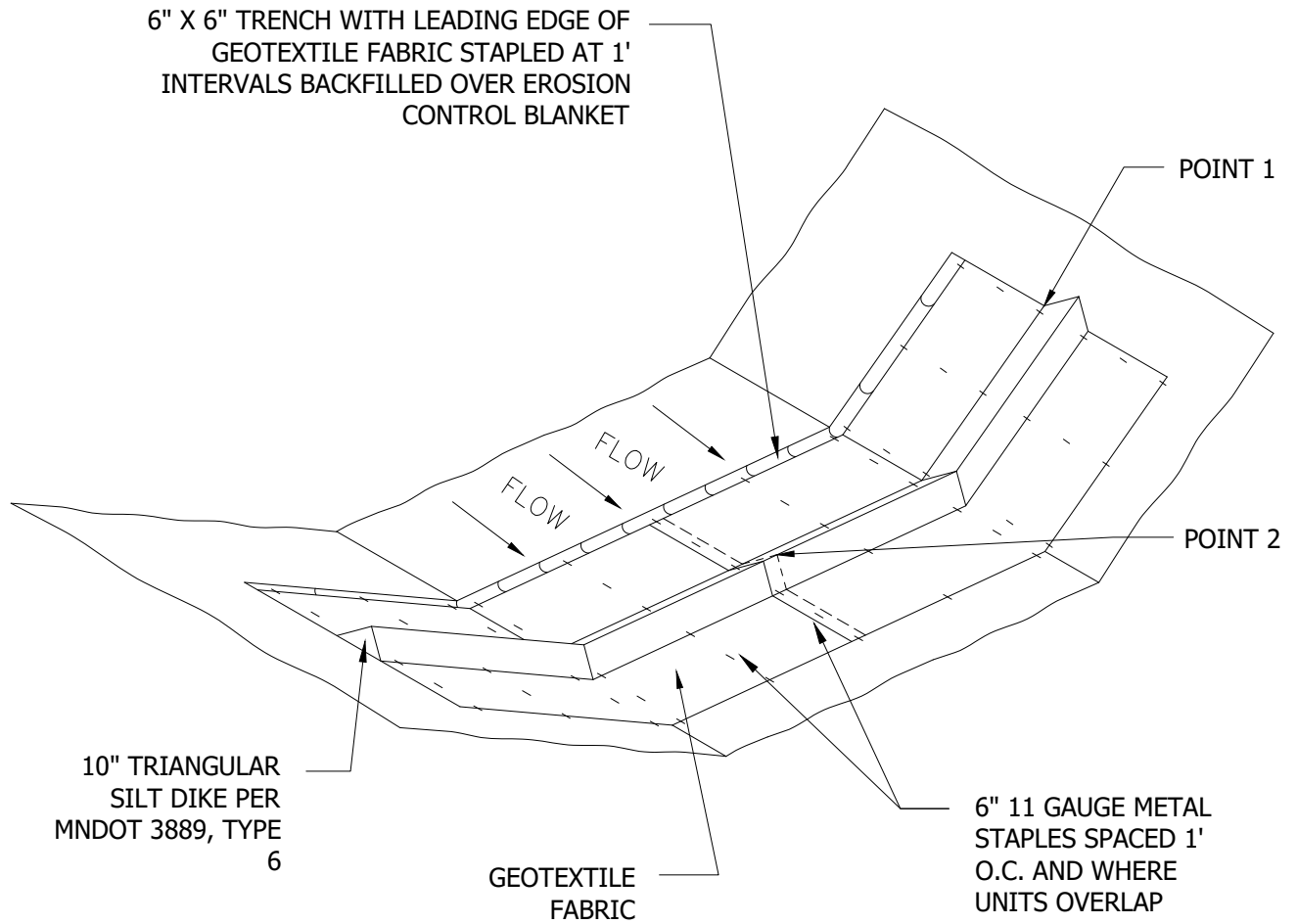

2026 DETAIL PLATES
REV.1

DITCH CHECK
TRIANGULAR SILT DIKE

LAST REVISION:
OCT 2024

PLATE NO.
ERO-05E

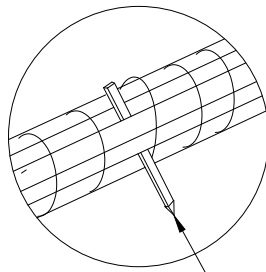

STAKE

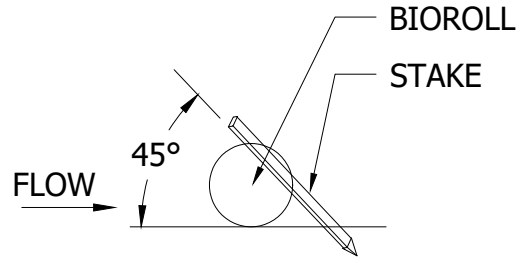

2" x 2" x 16" LONG WOODEN STAKES AT 1'-0" SPACING . STAKES SHALL BE DRIVEN THROUGH THE BACK HALF OF THE FILTER LOG AT AN ANGLE OF 45° WITH THE TOP OF THE STAKE POINTING UPSTREAM.

NOTE:
POINT 1 MUST BE A MINIMUM OF 6" HIGHER THAN POINT 2 TO ENSURE THAT WATER FLOWS OVER THE DIKE AND NOT AROUND THE ENDS.

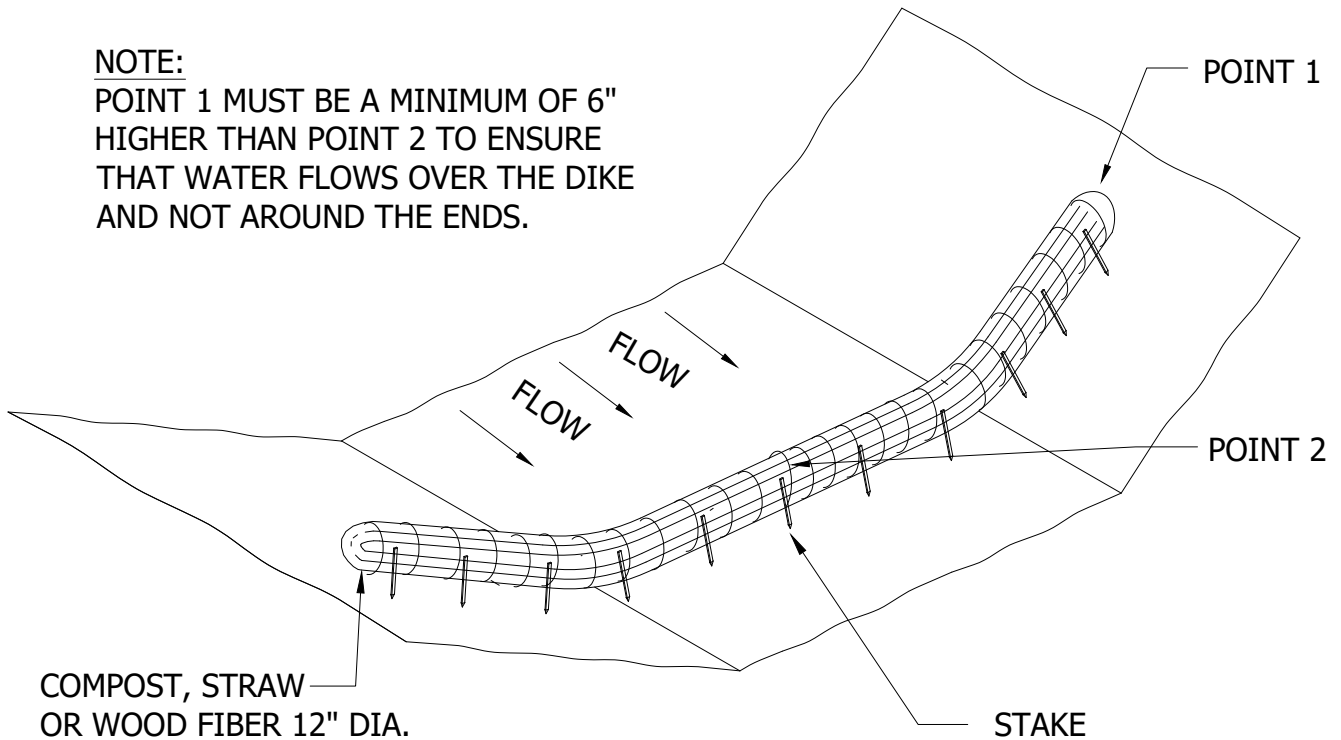

COMPOST, STRAW OR WOOD FIBER 12" DIA. ROLL ENCLOSED IN POLYPROPYLENE NETTING OR A GEOTEXTILE BAG.



2026 DETAIL PLATES
REV.1

FILTER LOG DITCH CHECK

LAST REVISION:
OCT 2024

PLATE NO.
ERO-06

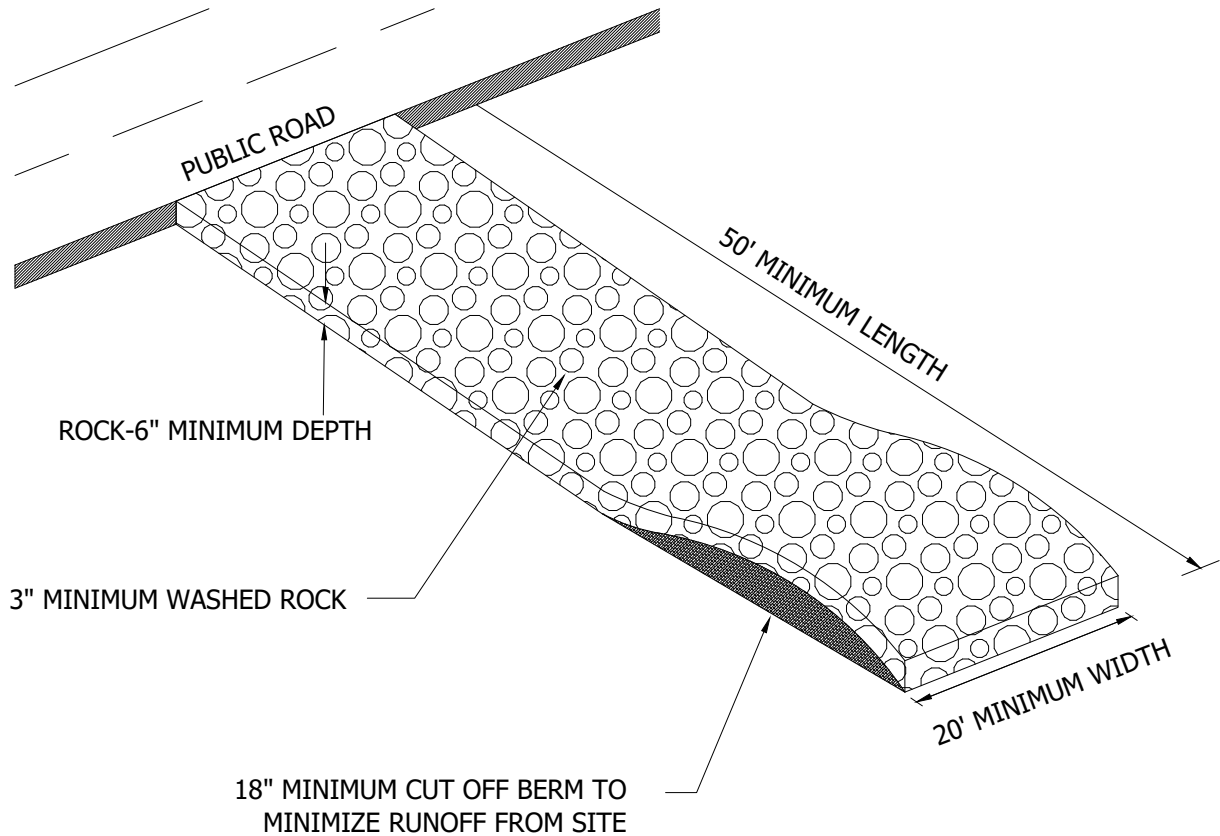

NOTES:
 FILTER FABRIC SHALL BE PLACED UNDER ROCK TO STOP MUD MIGRATION THROUGH ROCK.
 ENTRANCE MUST BE MAINTAINED REGULARLY TO PREVENT SEDIMENTATION ON PUBLIC ROADWAYS.



2026 DETAIL PLATES
 REV.1

CONSTRUCTION ENTRANCE
 ROCK

LAST REVISION:
 OCT 2024

PLATE NO.
 ERO-07

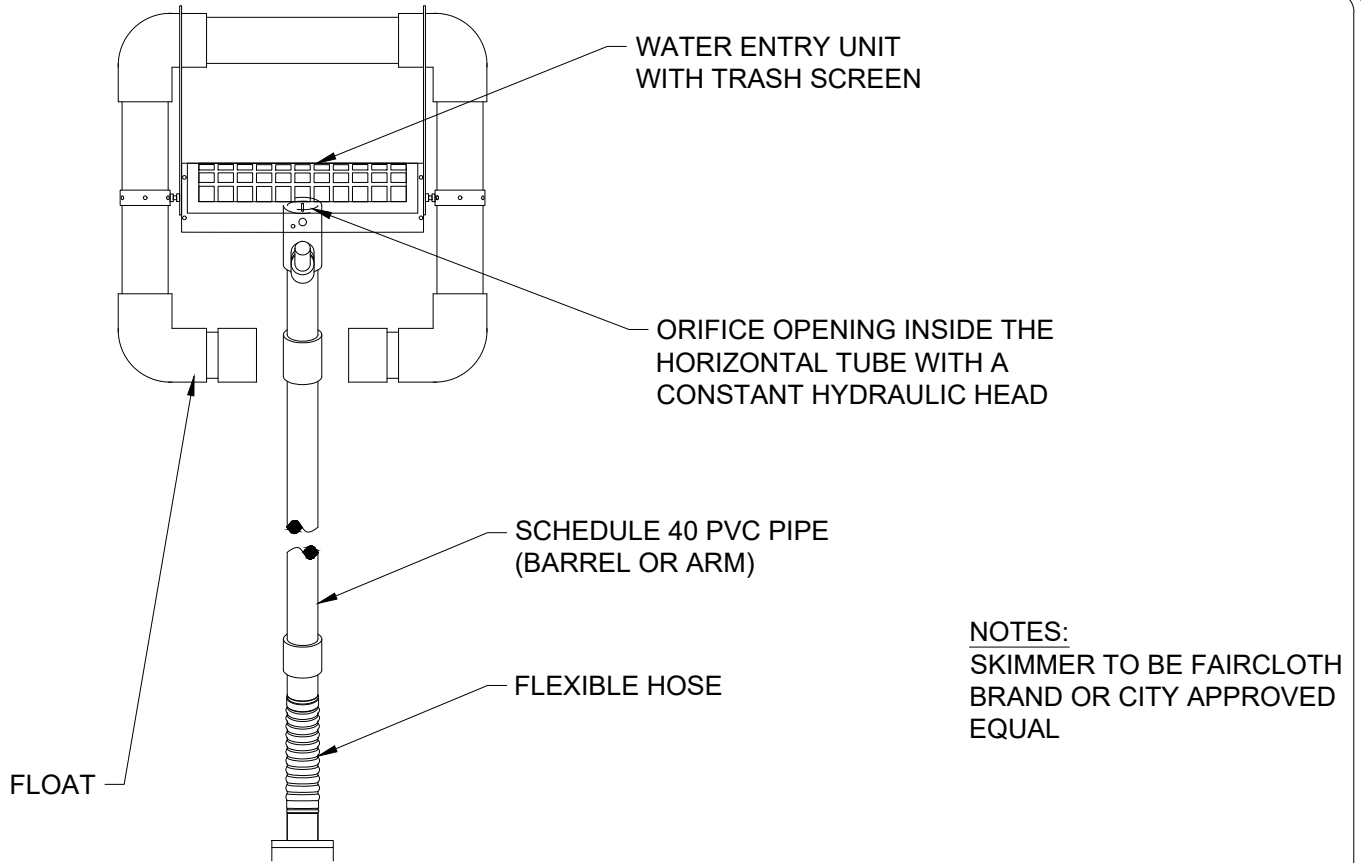

NOTES:
 SKIMMER TO BE FAIRCLOTH BRAND OR CITY APPROVED EQUAL

TOP VIEW

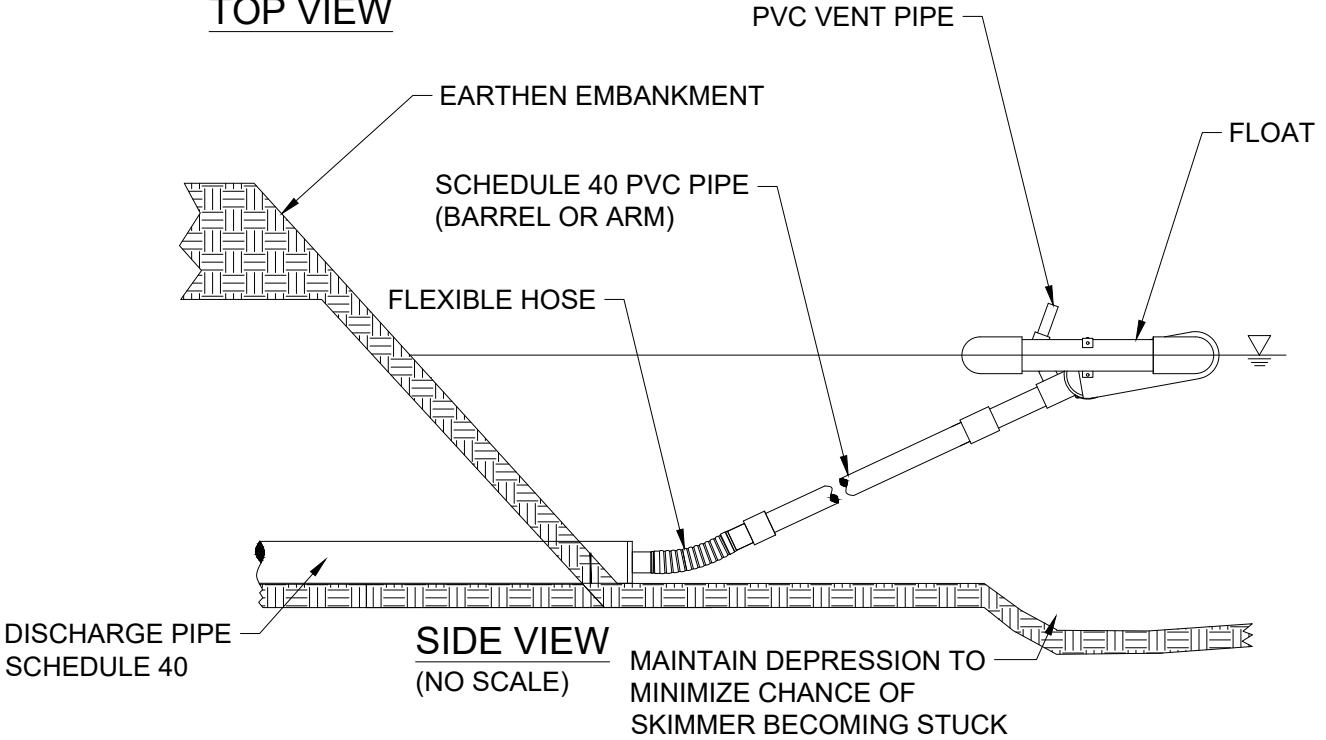

I. PLAN VIEW

NOTES:

BASIN USED FOR 10 ACRES DRAINAGE AREA OR MORE. DESIGN RUNOFF VOLUME IS FROM A 2-YR, 24-HR STORM PER ACRE DRAINED TO THE BASIN. BASIN VOLUME MUST BE A MIN. OF 1800 CUBIC FEET/ACRE. SEE PLANS/SPECIFICATIONS FOR BASIN DIMENSIONS AND PIPE SIZE AND SLOPE.

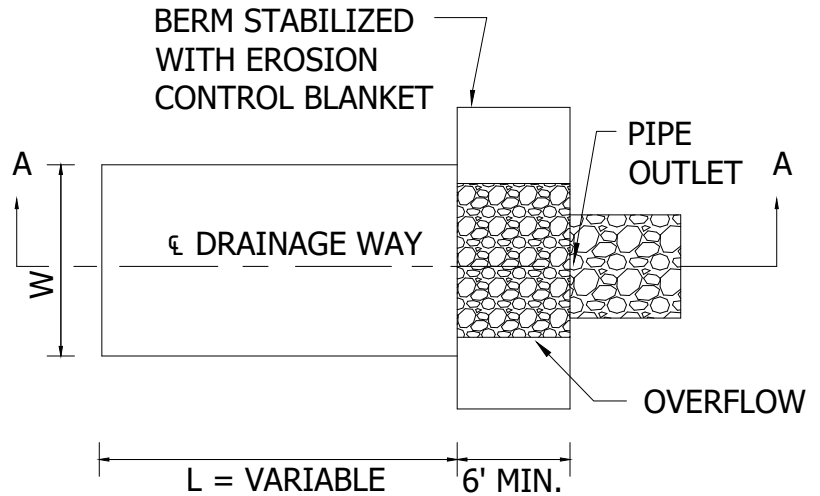

II. SECTION A-A

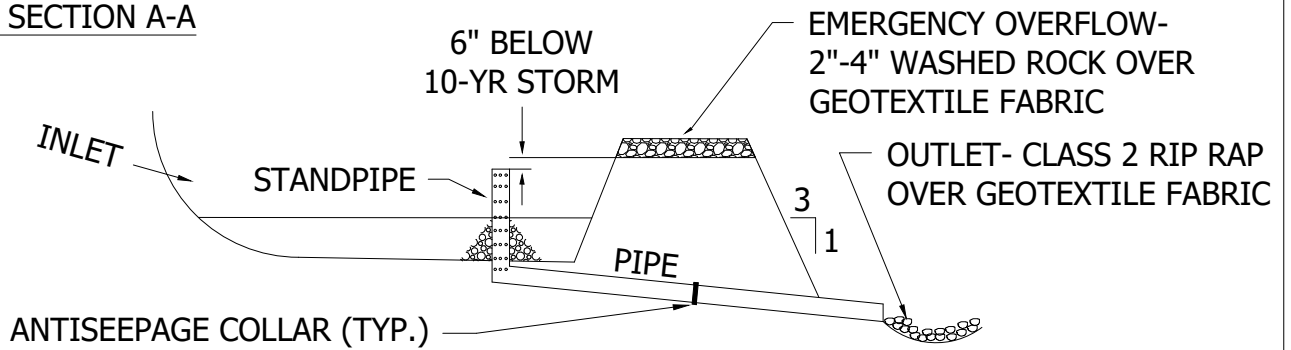

III. BASIN STANDPIPE AND EMERGENCY OVERFLOW

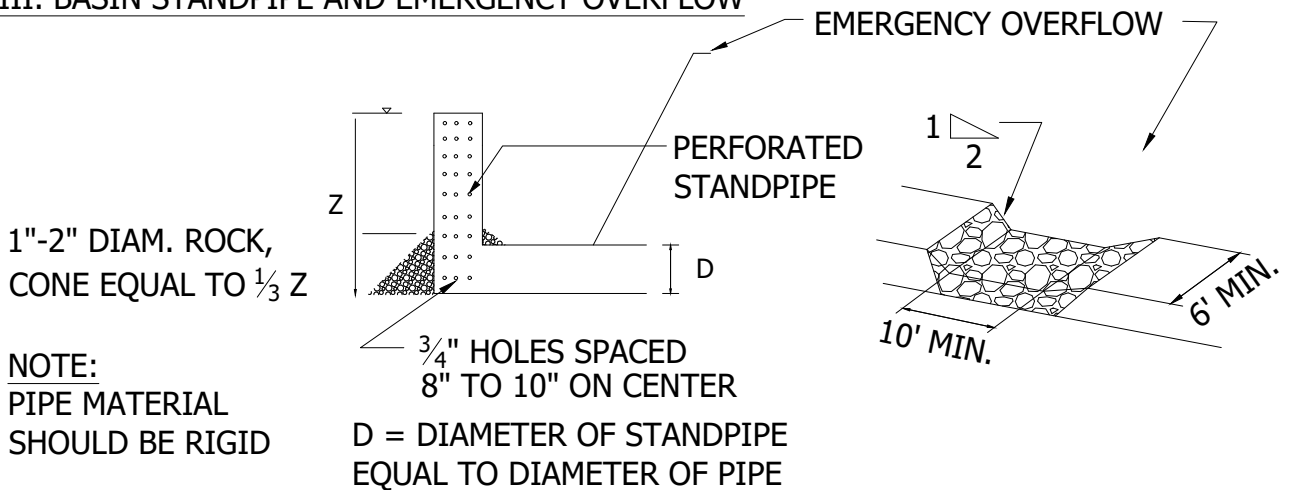

NOTE:
PIPE MATERIAL SHOULD BE RIGID

D = DIAMETER OF STANDPIPE EQUAL TO DIAMETER OF PIPE

I. PLAN VIEW

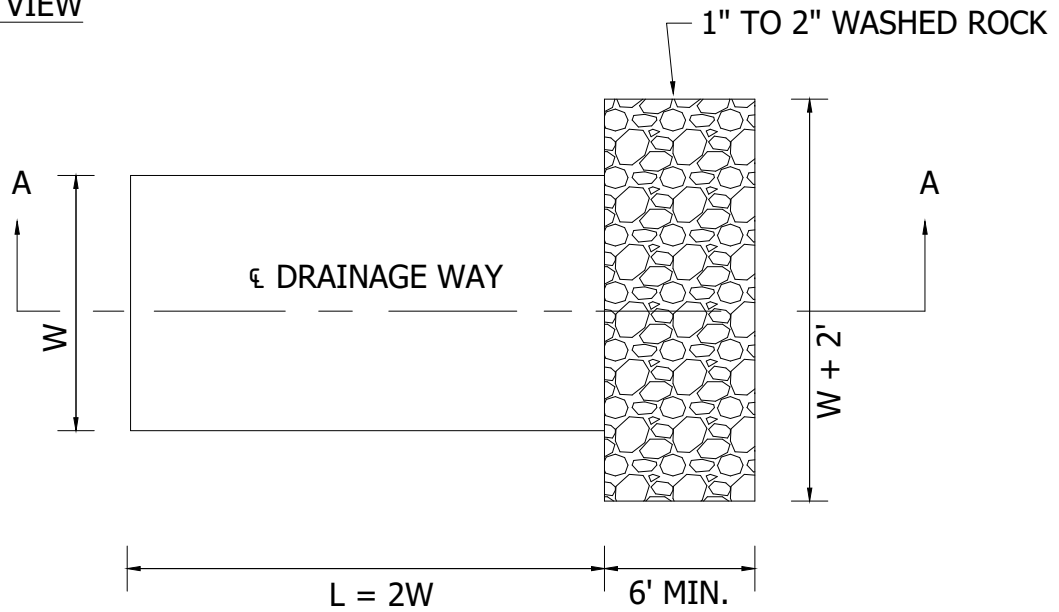

II. SECTION A-A

DIRECTION OF SURFACE FLOW

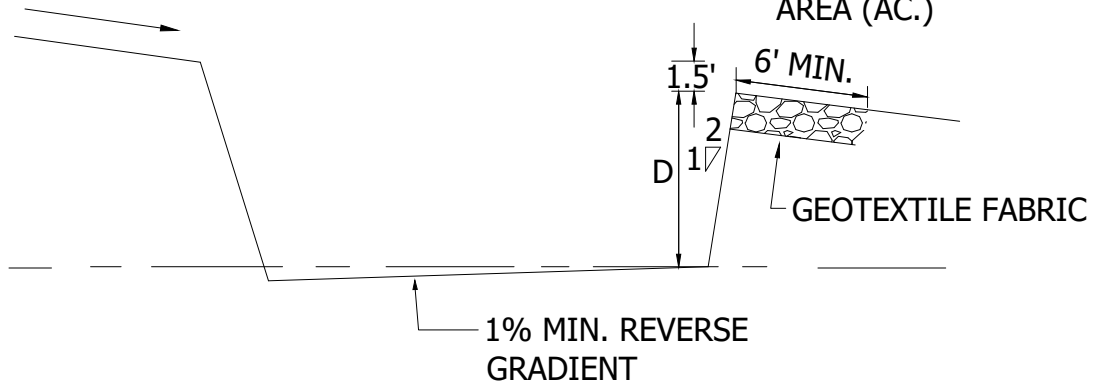

NOTE:

D=3' MIN, 5' MAX

W=10' MIN, 25' MAX

W(FT.)= 10 X DRAINAGE AREA (AC.)

III. TRAP OUTLET

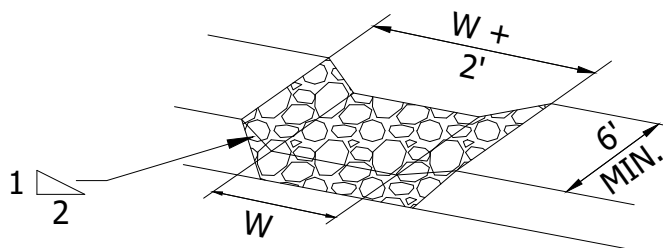

NOTES:

TRAP USED FOR 2.5 ACRES DRAINAGE AREA OR LESS. DESIGN VOLUME IS A MINIMUM OF 1800 CUBIC FEET PER ACRE OF CONTRIBUTING DRAINAGE AREA.



2026 DETAIL PLATES
REV.1

TEMPORARY SEDIMENT TRAP

LAST REVISION:
OCT 2024

PLATE NO.
ERO-09

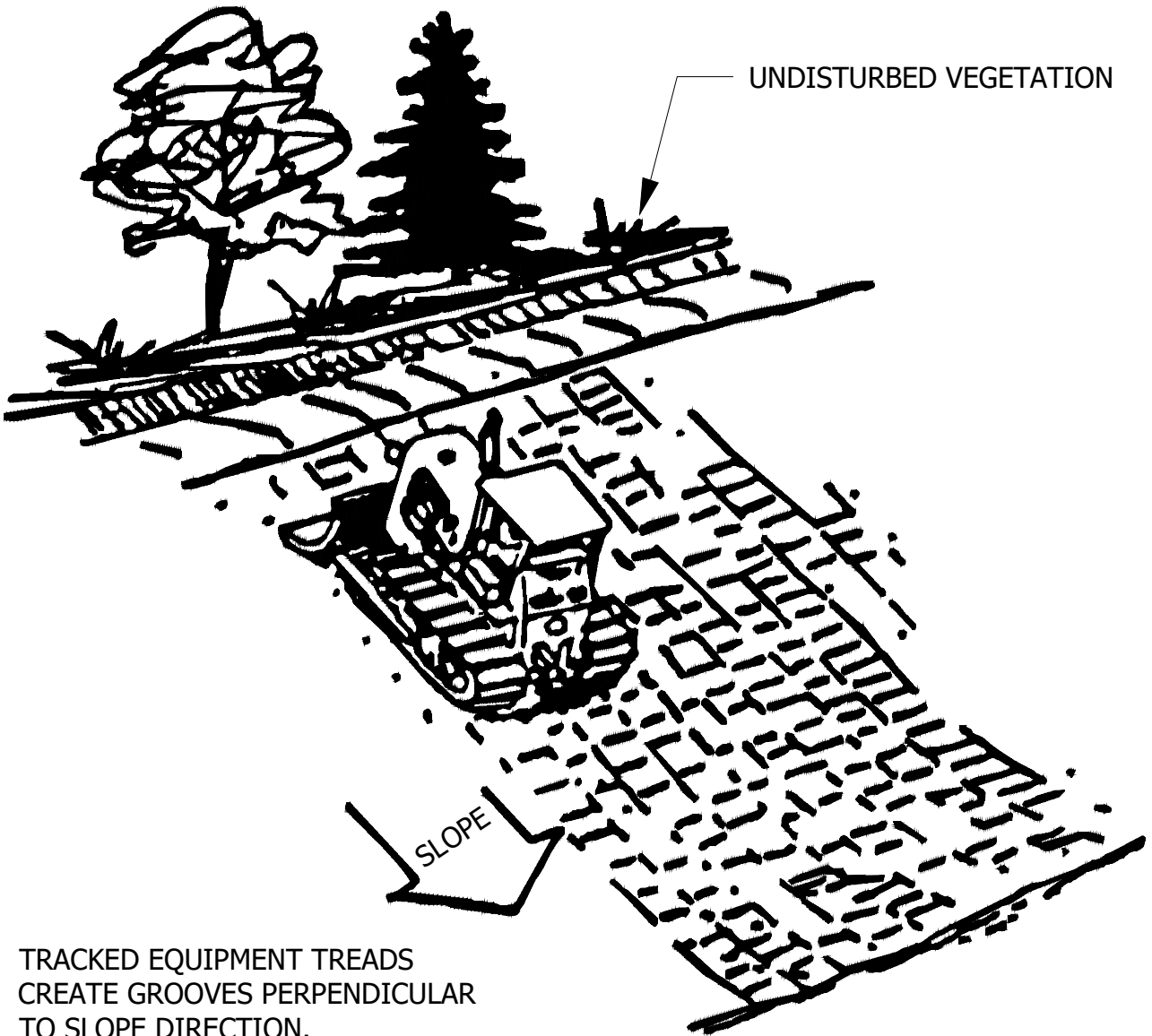

TRACKED EQUIPMENT TREADS
CREATE GROOVES PERPENDICULAR
TO SLOPE DIRECTION.

NOTE:

ALL SLOPES WITH A GRADE EQUAL TO OR STEEPER THAN
3:1 REQUIRE SLOPE TRACKING. SLOPES WITH A GRADE
MORE GRADUAL THAN 3:1 REQUIRE SLOPE TRACKING IF
THE STABILIZATION METHOD IS EROSION CONTROL
BLANKET OR HYDROMULCH.



2026 DETAIL PLATES
REV.1

SLOPE TRACKING

LAST REVISION:
OCT 2024

PLATE NO.
ERO-10

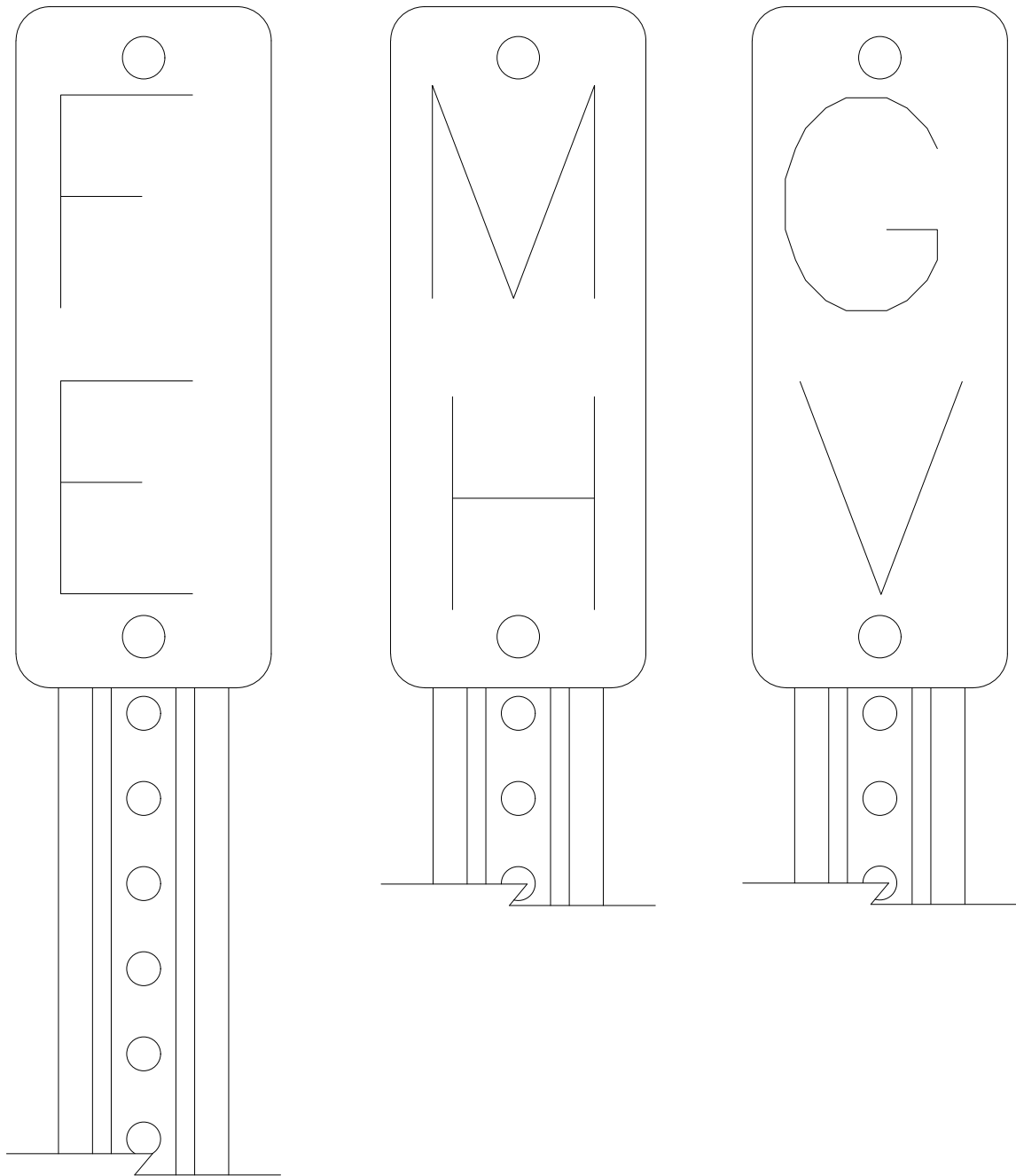

0.063" THICK ALUMINUM SIGN. BLACK LETTERS ON WHITE HIGH INTENSITY REFLECTORIZED BACKGROUND U-CHANNEL POST MINIMUM 3LB/FT 6-6" LONG, PAINTED GREEN. PLACED AS DIRECTED BY CITY ENGINEER.



2026 DETAIL PLATES
REV.1

STRUCTURE MARKER SIGNS

LAST REVISION:
OCT 2024

PLATE NO.
GEN-01

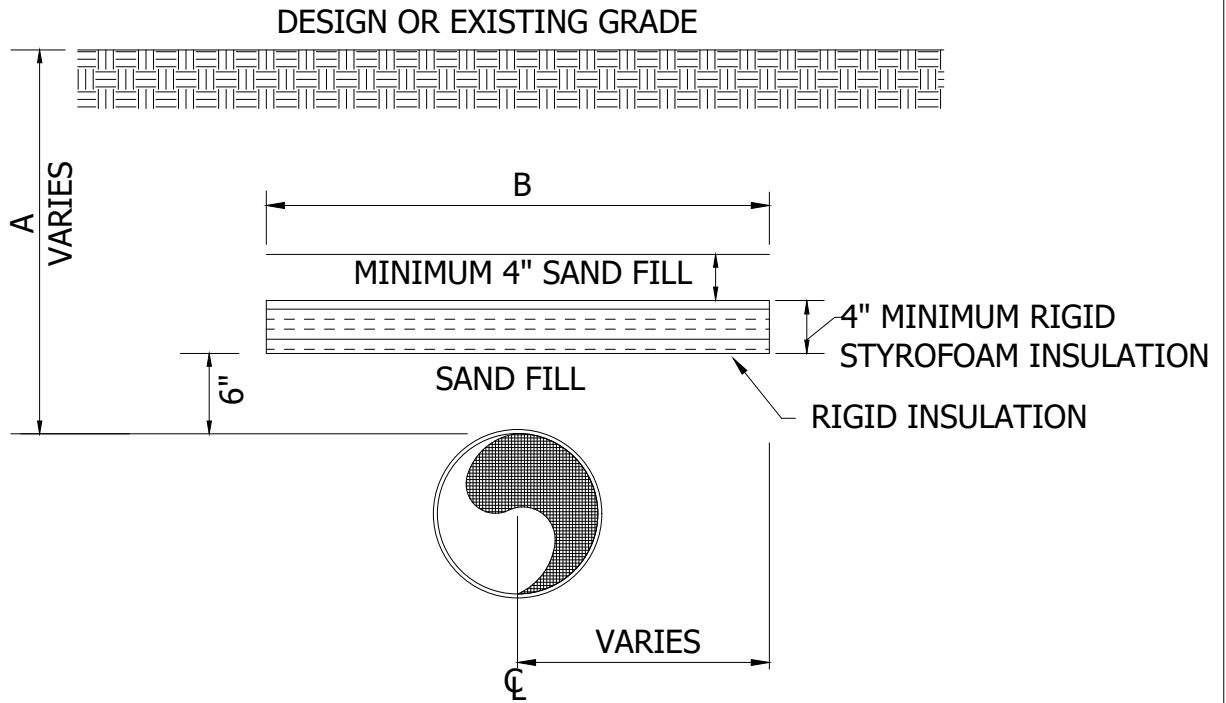

COVER OVER PIPE - A

5'

6'

WIDTH OF INSULATING BOARD - B

8'

4'

NOTES:

1. PIPE SHALL BE CENTERED UNDER INSULATION UNLESS OTHERWISE SPECIFIED.
2. WATER ABSORPTION, MAXIMUM = 0.1% BY VOLUME.
3. BOARDS MUST BE 4' WIDE AND 8' IN LENGTH.
4. COMPRESSIVE STRENGTH = MINIMUM 40 PSI



2026 DETAIL PLATES
REV.1

INSULATION DETAIL

LAST REVISION:
DEC 2025

PLATE NO.
GEN-02

NO PARKING BY
ORDER OF
PUBLIC WORKS
DEPARTMENT
SEAL COATING
PROJECT

DATE: _____

← WOOD LATHE

NOTE: SIGNS TO BE INSTALLED AT 100' SPACING ON BOTH SIDES OF THE STREET.



2026 DETAIL PLATES
REV.1

SEAL COAT SIGNS

LAST REVISION:
OCT 2024

PLATE NO.
GEN-03

SIGN NAME	DESIGNATION	SIZE
STOP	R1-1	30"X30"
YIELD	R1-2	36"X36"X36"
SPEED LIMIT	R2-1	24"X30"

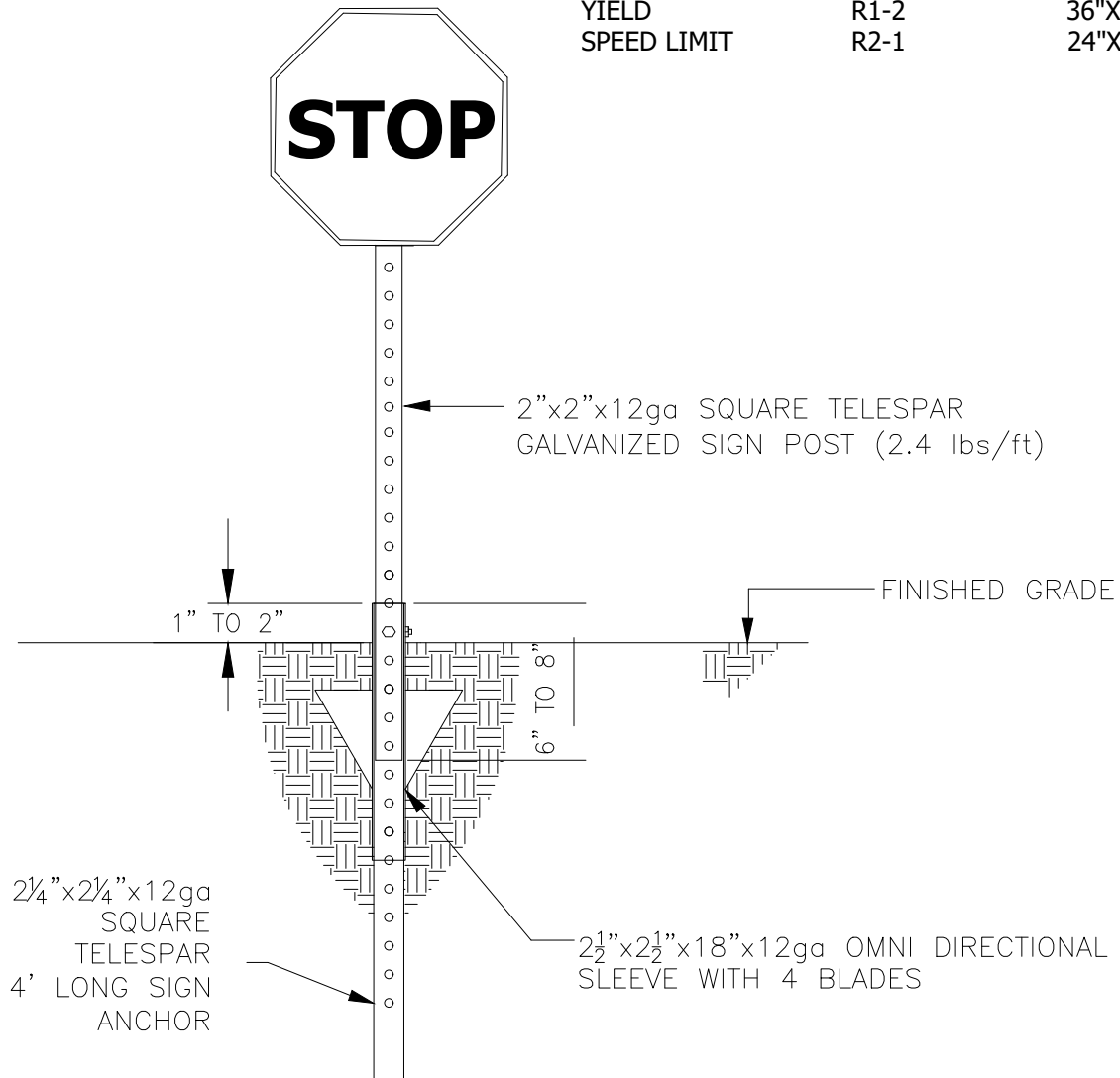

NOTE:

1. DESIGN SHALL CONFORM TO THESE REQUIREMENTS EXCEPT AS OTHERWISE APPROVED BY THE CITY ENGINEER.
2. SIGN SHALL BE REFLECTORIZED AS PER MNDOT 3352.2A3B, STANDARD NO. 2.
3. SIGN SHALL BE CONSTRUCTED OF ALUMINUM PER MNDOT 3352.2A1.
4. INSTALLATION SHALL BE IN COMPLIANCE WITH THE LATEST VERSION OF THE MINNESOTA MANUAL ON UNIFORM TRAFFIC CONTROL DEVICES.
5. FOR STREETS WITH SPEED LIMIT GREATER THAN 30 MPH, A 0.75' SIGN WITH 0.5' LETTERS IS REQUIRED.

SIGN NAME	DESIGNATION	SIZE
STOP	R1-1	30"X30"
YIELD	R1-2	36"X36"X36"
SPEED LIMIT	R2-1	24"X30"

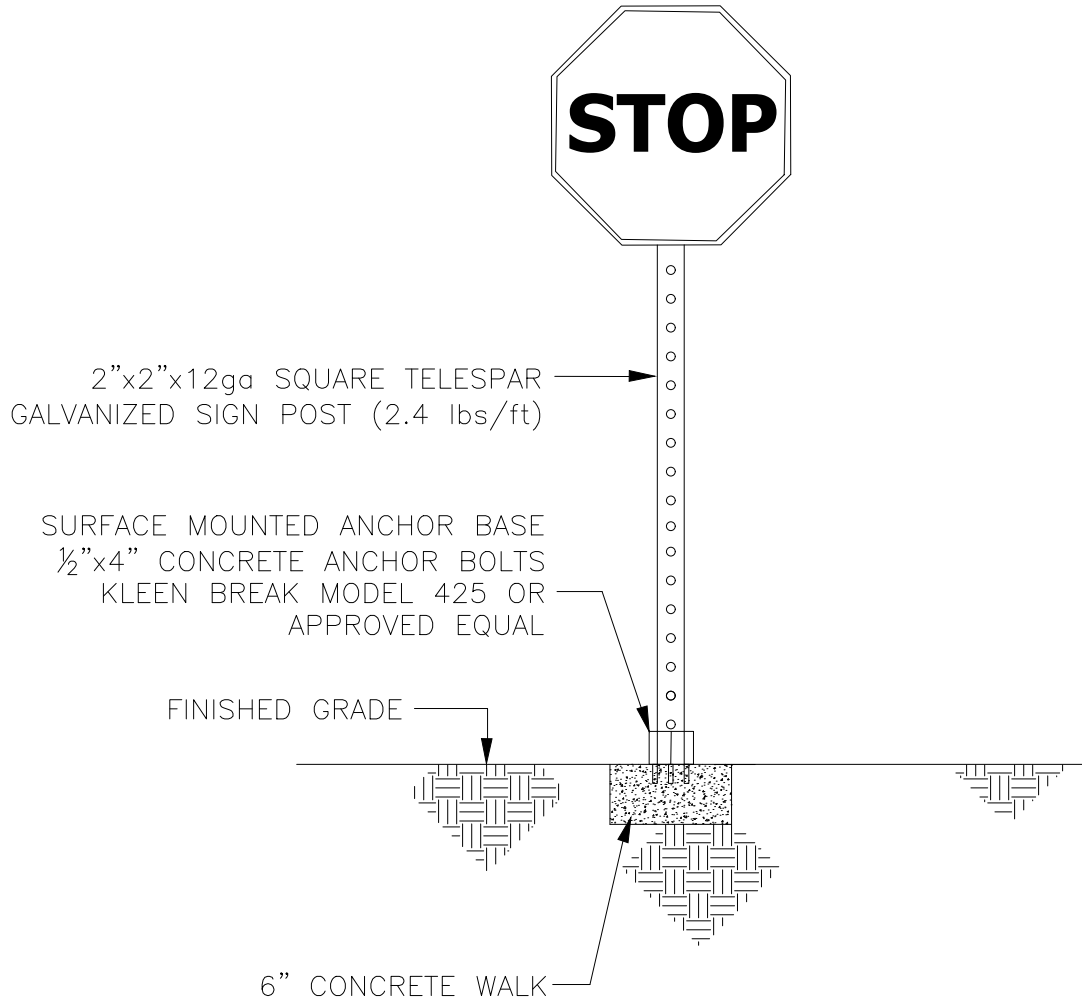

NOTE:

1. DESIGN SHALL CONFORM TO THESE REQUIREMENTS EXCEPT AS OTHERWISE APPROVED BY THE CITY ENGINEER.
2. SIGN SHALL BE REFLECTORIZED AS PER MNDOT 3352.2A3B, STANDARD NO. 2.
3. SIGN SHALL BE CONSTRUCTED OF ALUMINUM PER MNDOT 3352.2A1.
4. INSTALLATION SHALL BE IN COMPLIANCE WITH THE LATEST VERSION OF THE MINNESOTA MANUAL ON UNIFORM TRAFFIC CONTROL DEVICES.
5. FOR STREETS WITH SPEED LIMIT GREATER THAN 30 MPH, A 0.75' SIGN WITH 0.5' LETTERS IS REQUIRED.



FOR USE IN CUL-DE-SACS



- NOTES:
- DESIGN SHALL CONFORM TO THESE REQUIREMENTS EXCEPT AS OTHERWISE APPROVED BY THE CITY ENGINEER.
 - SIGN SHALL BE REFLECTORIZED AS PER MNDOT 3352.2A3B, STANDARD NO. 2
 - SIGN SHALL BE CONSTRUCTED OF ALUMINUM PER MNDOT 3352.2A1

INSTALLATION SHALL BE IN COMPLIANCE WITH THE LATEST REVISION OF THE MMUTCD

2" X 2" X 12 GAUGE SQUARE TELESPAR GALVANIZED SIGN POST (2.4 lbs/ft)

FINISHED GRADE

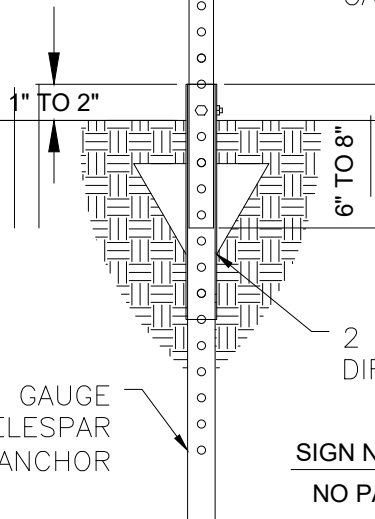

2 1/4" X 2 1/4" X 12 GAUGE SQUARE TELESPAR 4' LONG SIGN ANCHOR

SIGN NAME	DESIGNATION	SIZE
NO PARKING	N/A	12"X18"

NOTE:

- INSTALLATION SHALL BE IN COMPLIANCE WITH THE LATEST VERSION OF THE MINNESOTA MANUAL ON UNIFORM TRAFFIC CONTROL DEVICES.
- FOR STREETS WITH SPEED LIMIT GREATER THAN 30 MPH, A 0.75' SIGN WITH 0.5' LETTERS IS REQUIRED.
- NO PARKING SIGNS TO BE INSTALLED PER APPROVED SIGNAGE PLAN.
- SIGN SHALL BE CONSTRUCTED OF ALUMINUM PER MNDOT 3352.2A1.
- WHEN INSTALLED IN CONCRETE USE SURFACE MOUNTED ANCHOR BASE 1/2"x4" CONCRETE ANCHOR BOLTS KLEEN BREAK MODEL 425 OR APPROVED EQUAL. (SEE DETAIL GEN-04A)
- ALL NO PARKING SIGNS TO BE INSTALLED BACK-TO-BACK.

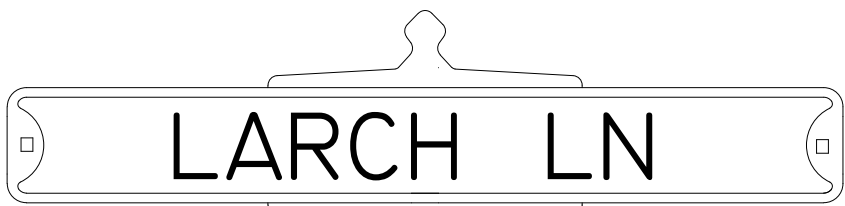

ALL BRACKETS SHALL BE GOPHER SIGN CO., G-100 SERIES BRACKETS OR APPROVED EQUAL. BRACKET COLOR SHALL BE GREEN ENAMEL.

2 3/8" O.D. GALVANIZED STEEL POST, 10' LONG, 3' TO BE BURIED IN CONCRETE.

ABBREVIATIONS ARE AS FOLLOWS:

- AVENUE = AVE
- PATH = PATH
- STREET = ST
- COURT = CT
- WAY = WAY
- TRAIL = TRL
- PLACE = PLACE
- CIRCLE = CIR
- DRIVE = DR
- LANE = LN
- BOULEVARD = BLVD
- ROAD = ROAD
- EAST = E
- PARKWAY = PKWY

HEIGHT OF SIGN = 9 IN.
 HEIGHT OF LETTERS = 6 IN.
 LENGTH OF SIGN = MAXIMUM 48 IN.

FINISHED GRADE

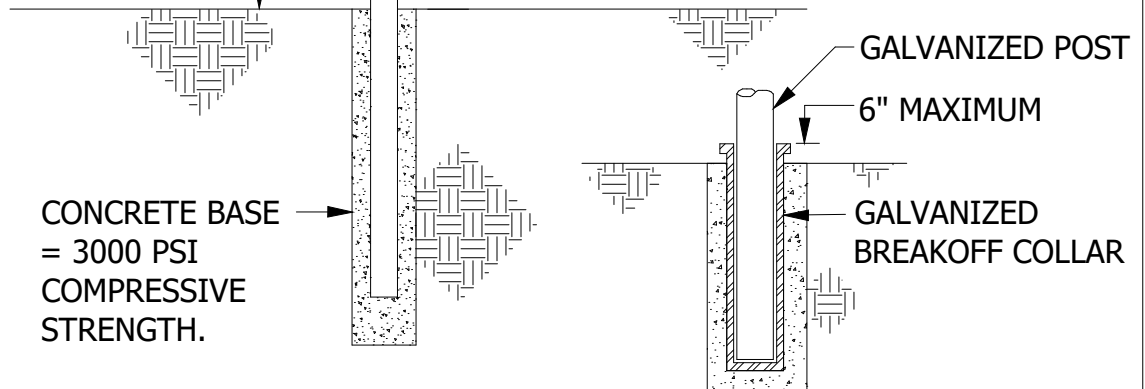

CONCRETE BASE = 3000 PSI COMPRESSIVE STRENGTH.

GALVANIZED POST

6" MAXIMUM

GALVANIZED BREAKOFF COLLAR

NOTE:

1. NUMBERED STREETS ARE TO BE WRITTEN OUT WHEN THE NUMBER IS NINETEENTH OR LESS.
2. INSTALLATION SHALL BE IN COMPLIANCE WITH THE LATEST VERSION OF THE MINNESOTA MANUAL ON UNIFORM TRAFFIC CONTROL DEVICES.
3. SIGN SHALL BE ALUMINUM PLATE WITH REFLECTORIZED WHITE LETTERS ON A GREEN BACKGROUND WITH TYPE AP BORDER STYLE.
4. TYPICALLY INSTALLED AT SOUTHWEST CORNER OF INTERSECTION. ALL EQUALS MUST BE APPROVED BY CITY ENGINEER BEFORE INSTALLATION.
5. SIGN SHALL BE CONSTRUCTED OF ALUMINUM PER MNDOT 3352.2A1.



(2) - SINGLE-FACED STREET SIGN PANELS WITH SPACERS.

1. STREET NAME LETTERING TO BE 6" ADDRESS LETTERING TO BE 3"
2. PRISMATIC WHITE COPY AND $\frac{3}{8}$ " BORDER
3. ON HIGH INTENSITY PRISMATIC BLUE
4. BACKGROUND
5. 1-1/2" RADIUS CORNERS
6. 2 EACH $\frac{3}{8}$ " HOLES ON 7" CENTERS
7. $\frac{3}{8}$ " HOLE EACH END IN 1" FROM EDGE
8. TO CENTER OF HOLE
9. SINGLE FACED
10. MAXIMUM LENGTH OF 42"

2" X 2" X 12 GAUGE SQUARE TELESPAR GALVANIZED SIGN POST (2.4 lbs/ft)

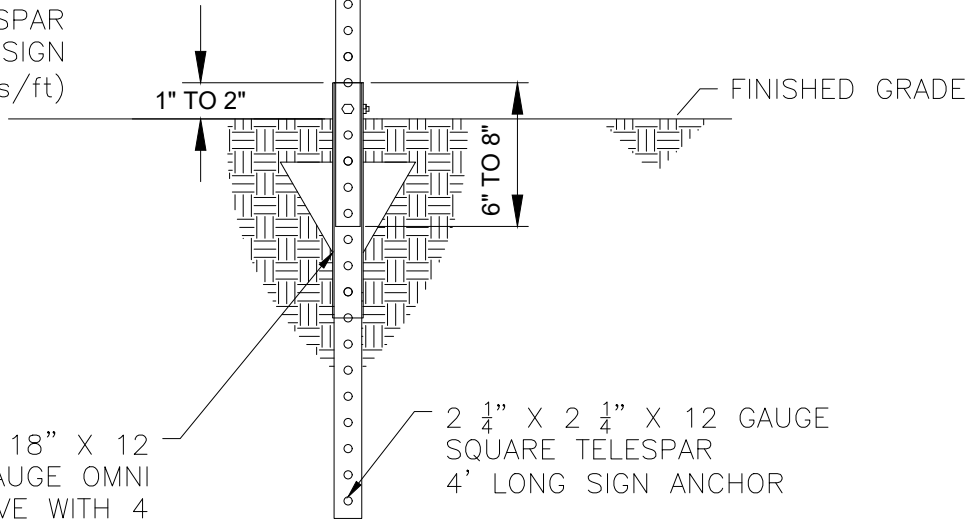

2 1/2" X 2 1/2" X 18" X 12 GAUGE OMNI DIRECTIONAL SLEEVE WITH 4 BLADES

2 1/4" X 2 1/4" X 12 GAUGE SQUARE TELESPAR 4' LONG SIGN ANCHOR

NOTE:

1. INSTALLATION SHALL BE IN COMPLIANCE WITH THE LATEST VERSION OF THE MINNESOTA MANUAL ON UNIFORM TRAFFIC CONTROL DEVICES.
2. SIGNS SHALL BE CONSTRUCTED OF ALUMINUM PER MNDOT 3352.2A1.



PRIVATE DRIVE SIGN - RESIDENTIAL

LAST REVISION:
OCT 2024

PLATE NO.
GEN-06A

(2) - SINGLE-FACED STREET SIGN PANELS WITH SPACERS

PRIVATE DRIVE

1. 6" C U/C & L/C HIGH INTENSITY
2. PRISMATIC WHITE COPY AND 3/8" BORDER ON HIGH INTENSITY PRISMATIC BLUE BACKGROUND
3. 1-1/2" RADIUS CORNERS
4. 2 EACH 3/8" HOLES ON 7" CENTERS
5. 3/8" HOLE EACH END IN 1" FROM EDGE
6. TO CENTER OF HOLE
7. SINGLE FACED
8. MAXIMUM LENGTH OF 42"

10001
10002
10003
MAIN ST

OR
RANGE
WHEN >10

10001 →
10012
MAIN ST

2" X 2" X 12 GAUGE SQUARE TELESPAR GALVANIZED SIGN POST (2.4 lbs/ft)

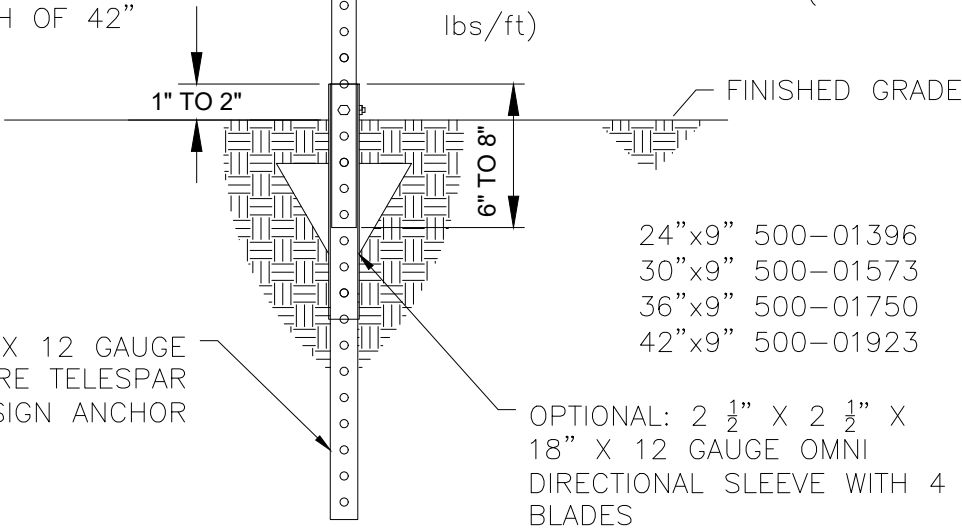

2 1/4" X 2 1/4" X 12 GAUGE SQUARE TELESPAR 4' LONG SIGN ANCHOR

- 24"x9" 500-01396
- 30"x9" 500-01573
- 36"x9" 500-01750
- 42"x9" 500-01923

OPTIONAL: 2 1/2" X 2 1/2" X 18" X 12 GAUGE OMNI DIRECTIONAL SLEEVE WITH 4 BLADES

NOTE:

1. INSTALLATION SHALL BE IN COMPLIANCE WITH THE LATEST VERSION OF THE MINNESOTA MANUAL ON UNIFORM TRAFFIC CONTROL DEVICES.
2. SIGNS SHALL BE CONSTRUCTED OF ALUMINUM PER MNDOT 3352.2A1.

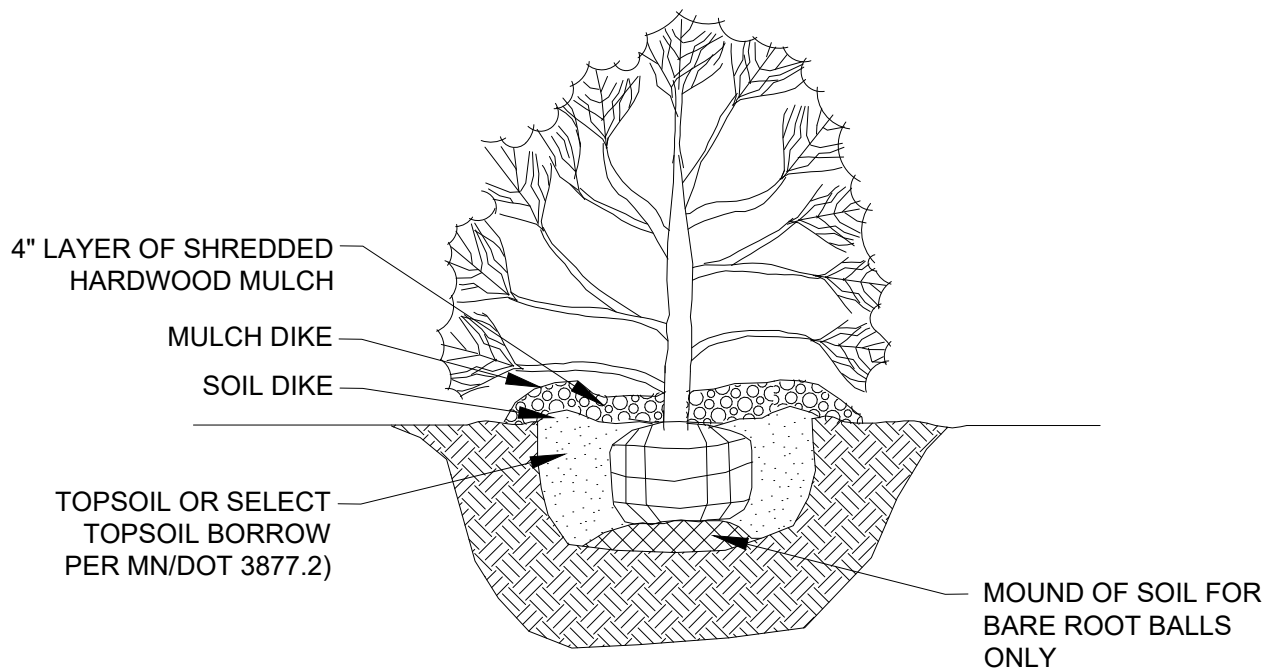

NOTES:

1. PLANTS TO BE INSTALLED AS PER THE AMERICAN ASSOCIATION OF NURSEYMAN (AAN) STANDARD PLANTING PRACTICES.
2. PROVIDE & INSTALL PLANT MATERIALS THAT ARE THE SIZE, TYPE, AND SPECIES INDICATED IN PLANS.
3. BEFORE PLANTING, REMOVE DEAD OR DAMAGED BRANCHES.
4. DIG HOLE TWO TIMES ROOT BALL WIDTH AND 6" DEEPER THAN BALL HEIGHT.
5. SCARIFY BOTTOM OF HOLE.
6. LOOSEN BURLAP COVERING ON ROOT BALL. REMOVE TOP OF BURLAP ON BALLED & BURLAPPED MATERIALS.
7. IF BARE ROOTED, SET BARE ROOT CROWN ON MOUND & SPREAD ROOTS OVER & DOWN SIDES OF MOUND.
8. PLANT TREE SO TOP OF ROOT BALL IS FLUSH WITH TOP OF SOIL.
9. FILL HOLE $\frac{2}{3}$ FULL OF SOIL & TAMP.
10. FILL REMAINING SPACE WITH WATER AND WAIT FOR IT TO SETTLE.
11. FINISH FILLING HOLE WITH SOIL AND MAKE A SOIL DIKE AROUND ROOT BALL.
12. CONTRACTOR SHALL VERIFY LOCATION OF ALL UTILITIES PRIOR TO DIGGING AND PLANT INSTALLATION.

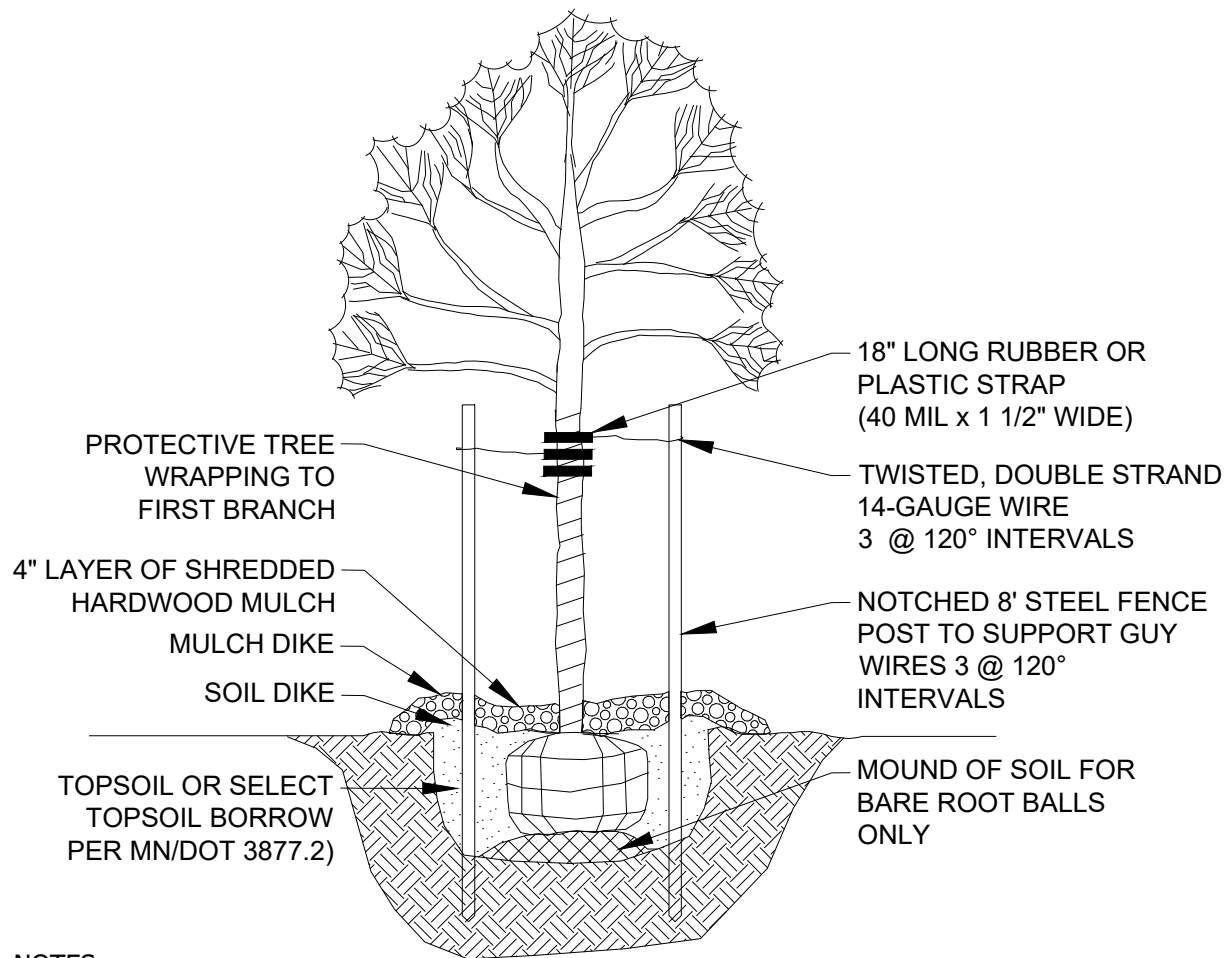

NOTES:

1. PLANTS TO BE INSTALLED AS PER THE AMERICAN ASSOCIATION OF NURSERYMAN (AAN) STANDARD PLANTING PRACTICES.
2. PROVIDE & INSTALL PLANT MATERIALS THAT ARE THE SIZE, TYPE, AND SPECIES INDICATED IN PLANS.
3. BEFORE PLANTING, REMOVE DEAD OR DAMAGED BRANCHES.
4. DIG HOLE 12" LARGER THAN ROOT BALL ON ALL SIDES.
5. SCARIFY BOTTOM OF HOLE.
6. LOOSEN BURLAP COVERING ON ROOT BALL. REMOVE TOP OF BURLAP ON BALLED & BURLAPPED MATERIALS.
7. IF BARE ROOTED, SET BARE ROOT CROWN ON MOUND & SPREAD ROOTS OVER & DOWN SIDES OF MOUND.
8. PLANT TREE SO TOP OF ROOT BALL IS FLUSH WITH TOP OF SOIL.
9. FILL HOLE $\frac{2}{3}$ FULL OF SOIL & TAMP.
10. FILL REMAINING SPACE WITH WATER AND WAIT FOR IT TO SETTLE.
11. FINISH FILLING HOLE WITH SOIL AND MAKE A SOIL DIKE AROUND ROOT BALL.
12. CONTRACTOR SHALL VERIFY LOCATIONS OF ALL UTILITIES PRIOR TO DIGGING AND PLANT INSTALLATION.

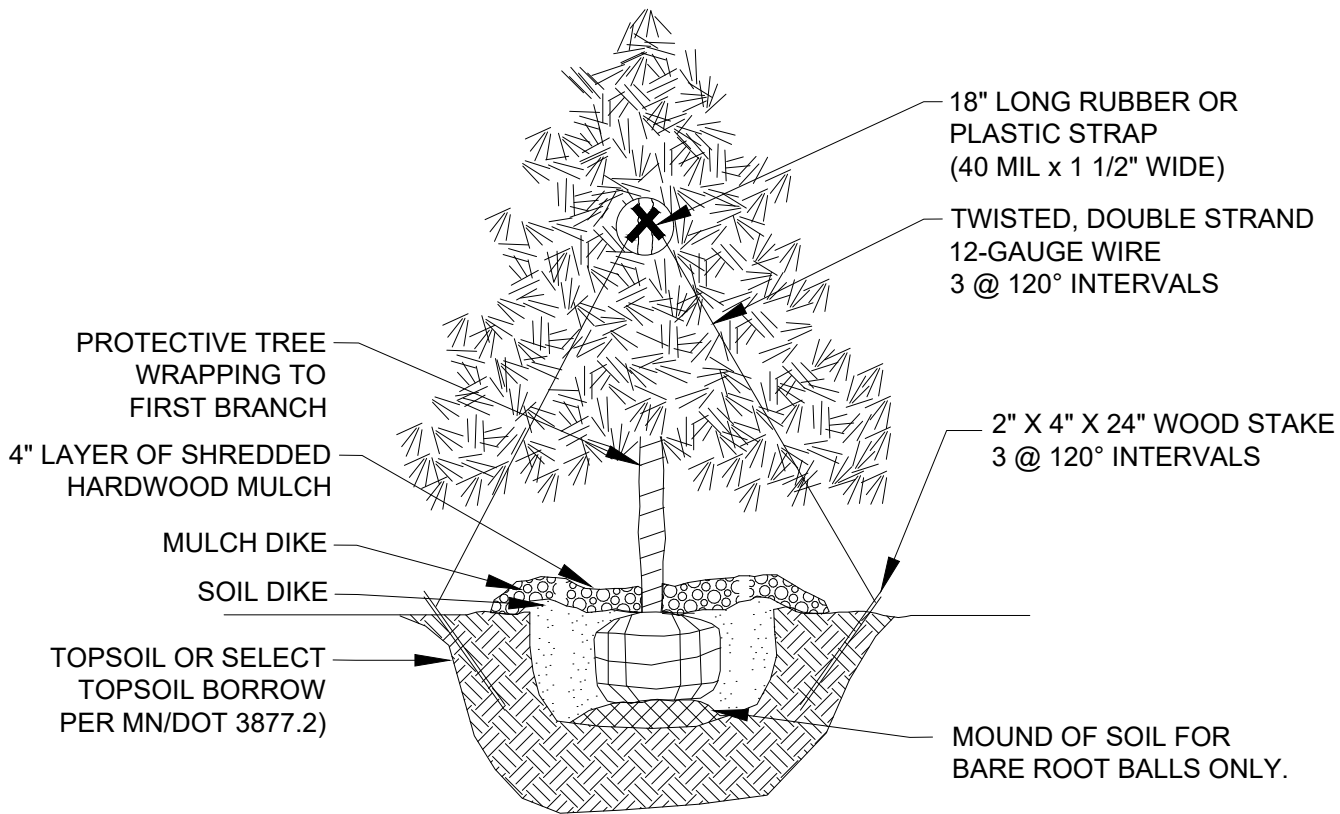

NOTES:

1. PLANTS TO BE INSTALLED AS PER THE AMERICAN ASSOCIATION OF NURSEYMAN (AAN) STANDARD PLANTING PRACTICES.
2. PROVIDE & INSTALL PLANT MATERIALS THAT ARE THE SIZE, TYPE, AND SPECIES INDICATED IN PLANS.
3. BEFORE PLANTING, REMOVE DEAD OR DAMAGED BRANCHES.
4. DIG HOLE TWO TIMES ROOT BALL WIDTH AND 6" DEEPER THAN BALL HEIGHT.
5. SCARIFY BOTTOM OF HOLE.
6. LOOSEN BURLAP COVERING ON ROOT BALL. REMOVE TOP OF BURLAP ON BALLED & BURLAPPED MATERIALS.
7. IF BARE ROOTED, SET BARE ROOT CROWN ON MOUND & SPREAD ROOTS OVER & DOWN SIDES OF MOUND.
8. PLANT TREE SO TOP OF ROOT BALL IS FLUSH WITH TOP OF SOIL.
9. FILL HOLE $\frac{2}{3}$ FULL OF SOIL & TAMP.
10. FILL REMAINING SPACE WITH WATER AND WAIT FOR IT TO SETTLE.
11. FINISH FILLING HOLE WITH SOIL AND MAKE A SOIL DIKE AROUND ROOT BALL.
12. CONTRACTOR SHALL VERIFY LOCATIONS OF ALL UTILITIES PRIOR TO DIGGING AND PLANT INSTALLATION.

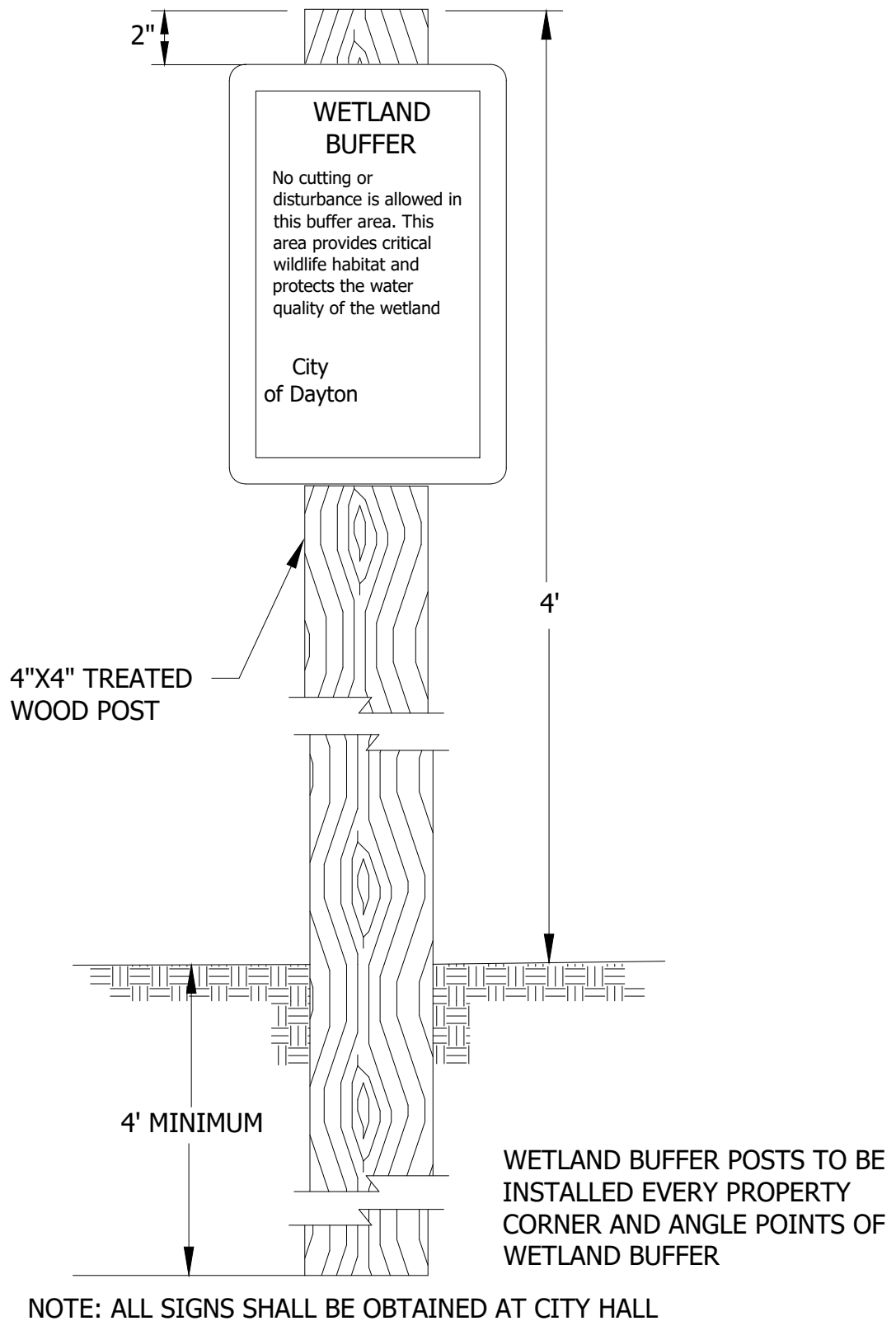

STALL DETAILS

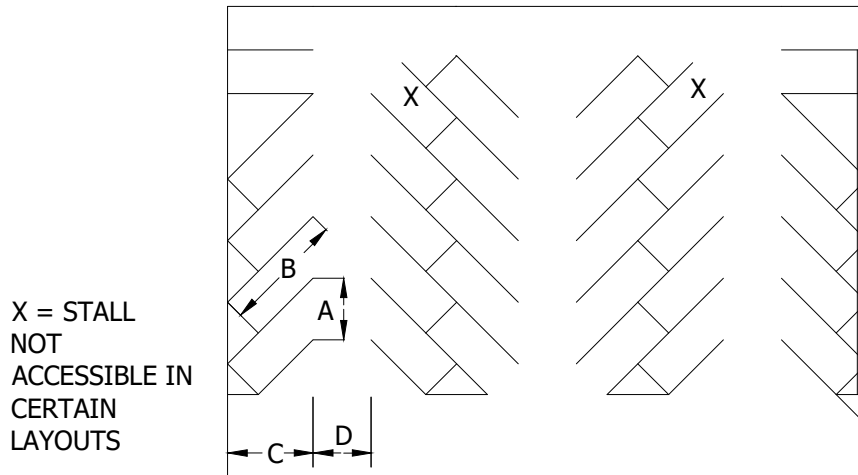

X = STALL NOT ACCESSIBLE IN CERTAIN LAYOUTS

PARKING LAYOUT DIMENSIONS (IN FEET) FOR 9-FT STALLS AT VARIOUS ANGLES					
	ON DIAGRAM	PARKING ANGLE			
		30	45	60	90
STALL WIDTH, PARALLEL TO AISLE	A	18.0	12.7	10.5	10.0
STALL LENGTH OF LINE	B	15.1	17.3	18.2	20.0
STALL DEPTH, TO WALL	C	17.4	19.9	21.0	20.0
AISLE WIDTH, ONE-WAY	D	12.0	13.0	18.0	24.0
AISLE WIDTH, TWO-WAY	-	24.0	24.0	24.0	24.0

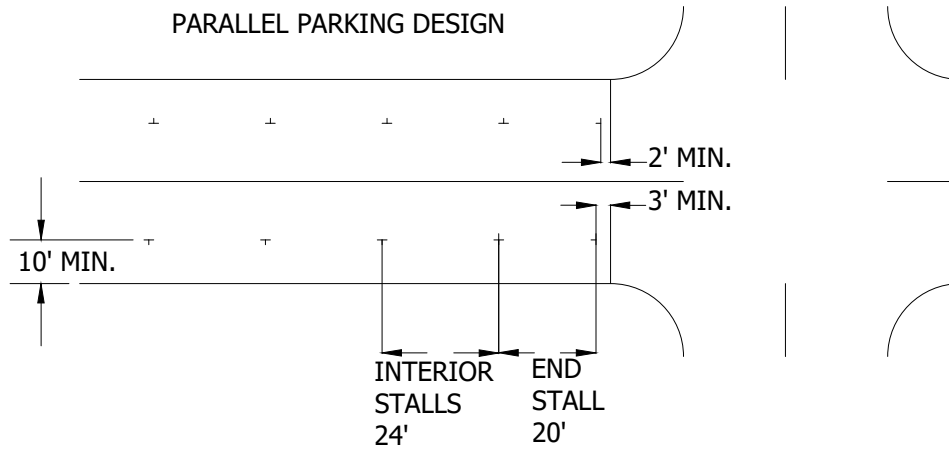

THIS WORK SHALL CONSIST OF THE CONTRACTOR PROVIDING SURVEY QUALITY X,Y,Z LOCATES OF ALL SANITARY SEWER, STORM SEWER, AND WATER DISTRIBUTION. THE DATA WILL BE COLLECTED DURING CONSTRUCTION, ONSITE USING A SURVEY GRADE GPS, IN THE HENNEPIN COUNTY COORDINATE SYSTEM. THE MNCORS CORRECTION SOURCE MOUNT POINT COORDINATE SYSTEM IS TO BE CMRX_NAD83(1996). THE REQUIRED ACCURACY FOR THE DATA COLLECTED SHALL BE 0.28 FOOT TOLERANCE.

THE SURVEY SHOTS MUST BE TAKEN AT THE FOLLOWING LOCATIONS AND SUBMITTED USING APPROVED NAMING CONVENTIONS AS OUTLINED IN THE TABLES BELOW:

SANITARY SEWER	
CODE	DESCRIPTION
SCO	SANITARY CLEANOUT
SSS	SANITARY STUB
SSL	SANITARY SLEEVE
SLS	SANITARY LIFT STATION WET WELL
SLSV	SANITARY LIFT STATION VALVE PIT
SFMTS	SANITARY FORCEMAIN TESTING STATION
SFBND	SANITARY FORCEMAIN BEND
SFM	SANITARY FORCEMAIN (POINT ON MAIN EVERY 50')
SABAND	SANITARY END OF ABANDONED PIPE
SWYE	SANITARY SERVICE WYE

STORM SEWER	
CODE	DESCRIPTION
STST	STORM STUB
STDTPPL	STORM DRAIN TILE PLUG
STDTBND	STORM DRAIN TILE BEND
STFBND	STORM FORCEMAIN BEND
STFM	STORM FORCEMAIN (POINT ON MAIN EVERY 50')
STDTCO	STORM DRAIN TILE CLEANOUT
STSDTST	STORM DRAIN TILE SERVICE STUB
STSDTWYE	STORM DRAIN TILE SERVICE WYE
STABAND	STORM END OF ABANDONED PIPE

WATER DISTRIBUTION	
CODE	DESCRIPTION
WGV	WATER GATE VALVE
WBND	WATER BEND (INCLUDING THE SIZE OF THE BEND)
WCROS	WATER CROSS
WIC	WATER INTERCONNECT
WPLUG	WATER PLUG/CAP
WRED	WATER REDUCER
WSL	WATER SLEEVE
WTEE	WATER TEE
WCORP	WATER SERVICE CORPORATION STOP
WCURB	WATER SERVICE CURB STOP
WABAND	WATER END OF ABANDONED PIPE

THE CONTRACTOR SHALL PROVIDE A MICROSOFT EXCEL SPREADSHEET, .CSV FILE, OR SHAPE FILE TO THE CITY WITH THE INFORMATION IN THE FOLLOWING COLUMN HEADINGS:

1. DESCRIPTION
2. Y COORDINATE
3. X COORDINATE
4. Z ELEVATION
5. CODE FOR ITEM LOCATED USING TABLES
6. ACCURACY OF X,Y,Z SHOTS (IN FT OR M)
7. DATE OF EACH SHOT
8. NOTES

THE CONTRACTOR WILL ONLY BE REQUIRED TO TAKE SHOTS OF ANY UTILITY THEY INSTALLED OR ALTERED IN ANY WAY. THE INTENT IS TO SURVEY ALL UTILITIES INSTALLED OR ALTERED THAT ARE BURIED.

QUALITY SERVICE LOCATES SHALL BE SUBMITTED TO THE CITY A MINIMUM OF ONE WEEK PRIOR TO CURB PLACEMENT. ANY ADDITIONAL DATA REQUIRED AFTER THAT POINT SHALL BE SUBMITTED SEPARATELY.

MANDREL SIZE

SDR 35 (DEPTH < 16')				
PIPE SIZE (IN)	DEFLECTION TEST		AIR TEST	
	BASE I.D. (IN)	5% DEFLECTION (IN)	PRESSURE* (PSIG)	TIME (MIN)
4	3.874	3.68	4	2
6	5.742	5.45	4	3
8	7.665	7.28	4	4
10	9.563	9.08	4	5
12	11.361	10.79	4	6
15	13.898	13.20	4	7.5

PS 46 (DEPTH < 16')				
PIPE SIZE (IN)	DEFLECTION TEST		AIR TEST	
	BASE I.D. (IN)	5% DEFLECTION (IN)	PRESSURE* (PSIG)	TIME (MIN)
18	16.976	16.13	4	9
21	20.004	19.00	4	10.5
24	22.480	21.36	4	12
27	25.327	24.06	4	13.5

SDR 26 (16' < DEPTH < 25')				
PIPE SIZE (IN)	DEFLECTION TEST		AIR TEST	
	BASE I.D. (IN)	5% DEFLECTION (IN)	PRESSURE* (PSIG)	TIME (MIN)
6	5.612	5.33	4	3
8	7.488	7.12	4	4
10	9.342	8.87	4	5
12	11.102	10.54	4	6
15	13.575	12.90	4	7.5

PS 115 (DEPTH < 16')				
PIPE SIZE (IN)	DEFLECTION TEST		AIR TEST	
	BASE I.D. (IN)	5% DEFLECTION (IN)	PRESSURE* (PSIG)	TIME (MIN)
18	16.586	15.76	4	9
21	19.545	18.57	4	10.5
24	21.964	20.87	4	12
27	24.744	23.51	4	13.5
30	28.763	27.32	4	15

C-900 DR 18 (DEPTH > 25')				
PIPE SIZE (IN)	DEFLECTION TEST		AIR TEST	
	BASE I.D. (IN)	5% DEFLECTION (IN)	PRESSURE* (PSIG)	TIME (MIN)
6	5.934	5.49	4	3
8	7.754	7.37	4	4
10	9.487	9.01	4	5
12	11.265	10.70	4	6
14	13.050	12.40	4	7
16	14.831	14.09	4	8
18	16.609	15.78	4	9
20	18.386	17.47	4	10
24	21.940	20.84	4	12

NOTE: SEE GEN-14 FOR SANITARY SEWER TESTING REQUIREMENTS

GENERAL TESTING NOTES:

1. PIPE MATERIAL AND TESTING REQUIREMENTS MAY CHANGE DEPENDING ON SOIL CONDITIONS AND OTHER FACTORS.
2. ALL TESTING TO OCCUR BEFORE BUILDING PERMITS ARE ISSUED OR CONSTRUCTION OF WEAR COURSE PAVEMENT.
3. CITY TO BE NOTIFIED MINIMUM 48 HOURS BEFORE ANY UTILITY TESTING OR BUILDING PERMIT.

SANITARY SEWER TESTING NOTES:

1. A MINIMUM WAITING TIME PERIOD OF 30 DAYS AFTER INSTALLATION IS REQUIRED BEFORE DEFLECTION TEST MAY BE PERFORMED. (SEE GEN-13)
2. TRACER WIRE TEST TO BE PERFORMED ON ALL SANITARY SEWER AND SANITARY SEWER SERVICES BY METROTECH OR APPROVED EQUAL.
3. AIR TEST WILL BE PERFORMED AT A PRESSURE OF 4.0 PSIG GREATER THAN THE AVERAGE BACKPRESSURE OF ANY GROUND WATER PRESENT.
6. *IF GROUNDWATER IS PRESENT, FOR EVERY FOOT OF GROUND WATER ABOVE THE PIPE SPRING LINE, INCREASE THE GAGE TEST PRESSURE BY 0.43 PSI (TO COMPENSATE FOR WATER BACK PRESSURE). (SEE GEN-13)
7. THE SEWER LINE WHICH IS BEING TESTED WILL BE ACCEPTED AS PASSING THE AIR TEST IF THE PRESSURE DOES NOT DROP MORE THAN 0.0 PSI IN LESS TIME THAN 30 SECONDS PER INCH IN DIAMETER OF THE PIPE BEING TESTED.
8. TELEVISION SHALL BE PERFORMED ON ALL NEWLY INSTALLED GRAVITY SEWER FOLLOWING ALL OTHER SUCCESSFUL TESTING.
9. SANITARY SEWER TO BE JETTED PRIOR TO TELEVISION.
6. ALL PROXIMATE STORM SEWER MUST BE INSTALLED BEFORE WATERMAIN TESTING BEGINS.

FORCEMAIN TESTING NOTES:

1. FORCEMAIN HYDROSTATIC TEST PROCEDURE AS FOLLOWS:
 - 1.1. PUMP SYSTEM TO MINIMUM 75 PSI.
 - 1.2. THE FORCEMAIN SYSTEM WILL BE ACCEPTED AS PASSING IF THE PRESSURE HAS NO DROP IN PRESSURE IN 2 HOURS.
2. GAUGE TO BE USED WILL BE AN ASHCROFT, MODEL 1082, 4 1/2" DIAMETER IN ONE PSI INCREMENTS OR APPROVED EQUAL.
3. TRACER WIRE TEST REQUIRED FOR ALL FORCEMAIN TRACER WIRE

WATERMAIN TESTING NOTES:

1. WATERMAIN TESTING TO INCLUDE ALL CURB STOPS AND HYDRANT LEADS.
2. HYDROSTATIC PRESSURE TEST PROCEDURE AS FOLLOWS:
 - 2.1. PUMP SYSTEM TO MINIMUM 150 PSI.
 - 2.2. THE WATERMAIN SYSTEM WILL BE ACCEPTED AS PASSING IF THE PRESSURE HAS NO DROP IN PRESSURE IN 2 HOURS.
 - 2.3. ALL BUTTERFLY VALVES TO BE INDIVIDUALLY HYDROSTATICALLY TESTED AGAINST BOTH SIDES OF VALVE.
3. BACTERIA TEST (MINIMUM 2 SETS)
 - 3.1. 1 TEST FOR EVERY 1200 LF
 - 3.2. 1ST SET OF TESTS 24 HOURS AFTER INITIAL FLUSHING.
 - 3.3. SECOND SET OF TESTS TO BE TAKEN AFTER PASSING RESULTS FROM FIRST TEST, MINIMUM 24 HOURS AFTER FIRST TEST.
4. TRACER WIRE TEST TO BE PERFORMED BY A METROTECH OR APPROVED EQUAL. TRACER ENTIRE LINE/ALL SERVICES TO CURB STOPS.
5. WATERMAIN TESTING TO MEET MINNESOTA DEPARTMENT OF HEALTH STANDARDS.
6. ALL PROXIMATE STORM SEWER MUST BE INSTALLED BEFORE WATERMAIN TESTING BEGINS.

STORM SEWER TESTING NOTES:

1. TELEVISION SHALL BE PERFORMED ON ALL NEWLY INSTALLED STORM SEWER.
2. TELEVISION SHALL BE PERFORMED ON ALL DRAINTILE BEFORE WEAR COURSE AND AFTER PRIVATE UTILITIES ARE INSTALLED.
3. TELEVISION SHALL BE PERFORMED ON ALL REAR YARD DRAINTILE AFTER RESTORATION IS COMPLETE.
4. ALL TELEVISION TAPES TO BE EMAILED TO CITY REPRESENTATIVE AND NOTIFIED WHEN TELEVISION.
5. ANY TELEVISION REQUIRED SHALL BE INCIDENTAL.

RESIDENTIAL BUILDING PERMIT GRADING REQUIREMENTS

LAND SURVEYS/CERTIFICATES OF SURVEY MUST BE PREPARED BY A MINNESOTA LICENSED LAND SURVEYOR. IT IS RECOMMENDED THAT LAND SURVEYS MEET THE STANDARDS OF THE AMERICAN LAND TITLE ASSOCIATION (ALTA) AND AMERICAN CONGRESS OF SURVEYING AND MAPPING (ASCM). COMPLETE AND ACCURATE INFORMATION WILL EXPEDITE THE PLAN REVIEW PROCESS.

1. CERTIFICATE OF SURVEY

A CERTIFICATE OF SURVEY IS REQUIRED TO OBTAIN A BUILDING PERMIT FOR NEW CONSTRUCTION AND MAY BE REQUIRED FOR BUILDING OR ACCESSORY STRUCTURE ADDITIONS OR SIGNIFICANT GRADING CHANGES WHEN A LAND SURVEY IS NOT IN CITY RECORDS.

2. GRADING AS-BUILT

A GRADING AS-BUILT IS REQUIRED TO RELEASE ESCROW HELD ON THE LOT DURING CONSTRUCTION. FOR NEW CONSTRUCTION AND WHEN OTHERWISE REQUIRED BY THE CITY, AFTER FINAL GRADING, A LAND SURVEY OF EXISTING/"AS-BUILT" CONDITIONS MUST BE PREPARED AND SUBMITTED SHOWING CONFORMANCE WITH REQUIRED BUILDING SETBACKS, LOCATIONS, ELEVATIONS, AND GRADING.

PROPOSED SURVEYS MUST SHOW

CERTIFICATION

- *LAND SURVEYOR CERTIFICATION *SCALE AND NORTH ARROW
- *LEGAL DESCRIPTION *PREPARATION DATE AND REVISION DATES
- *PERMANENT SURVEY MONUMENT AND DESCRIPTION

FEATURES

- *FOUNDATION TYPE (FULL BASEMENT, WALKOUT, LOOKOUT, ETC.)
- *LOT DIMENSIONS
- *BUILDING SETBACKS
- *PROPERTY AND EASEMENT LINES
- *ADJACENT SIDEWALKS, CURBS, AND STREETS
- *DELINEATED WETLAND EDGE
- *EDGE OF WETLAND BUFFER WITH BUFFER SIGN LOCATIONS
- *DRIVEWAYS, TRAILS, AND PATHWAYS
- *TREE LINES/EDGE OF CANOPY
- *WELL, SEPTIC SYSTEMS, TANKS
- *LOCATIONS AND DIMENSIONS OF EXISTING AND PROPOSED STRUCTURES
- *WETLANDS, PONDS, LAKES, STREAMS, DRAINAGE SWALES, ETC.
- *SETBACKS TO OHW/NHW CONTOUR, WETLANDS, PONDS, LAKES, RIVERS
- *100-YEAR HWL, AND DRAINAGE AND UTILITY EASEMENT (NOTE: D AND U TO ENCOMPASS ALL DRAINAGE)
- *WATERMAIN, GATE VALVES, HYDRANTS, SANITARY AND STORM SEWER, DRAINTILE AND DRAINTILE CLEANOUTS, CATCHBASINS, AND MANHOLES (INCLUDING LINWORK ASSOCIATED WITH WATER, SANITARY, AND STORM)
- *DRAINAGE OUTLETS, OUTLET CONTROL STRUCTURES, AND EMERGENCY OVERFLOWS
- *VISIBLE AND UNDERGROUND COMPONENTS OF PUBLIC AND PRIVATE UTILITIES INCLUDING WATER AND SEWER STUBS AND SIZES
- *LANDSCAPING AS SHOWN ON APPROVED LANDSCAPING PLANS. RETAINING WALLS AND FENCES

ELEVATIONS

- *LOT CORNER ELEVATIONS, EXISTING LOT ELEVATIONS, AND PROPOSED ELEVATIONS AND CONTOURS PER APPROVED GRADING PLAN
- *SPOT ELEVATIONS AT THE MINIMUM REQUIREMENTS OF 25' OR GROUND BREAKS SHOWING A MINIMUM OF 2% DRAINAGE AND A MAXIMUM OF 25% (4:1) SLOPES IN MAINTAINED AREAS. A MAXIMUM GRADE OF 33% (3:1) SLOPES IN NON-MAINTAINED AREAS SUCH AS BUFFERS ARE ALLOWED OR APPROVED BY CITY ENGINEER. LOWEST GROUND ELEVATION ADJACENT TO THE BUILDING, LOT CORNERS, HIGH POINT DRAINAGE BREAKS, WHERE DRAINAGE SWALES INTERSECT LOT LINES, AND WHERE PONDING EASEMENTS INTERSECT LOT LINES.
- *THE GROUND ADJACENT TO THE FOUNDATION SHALL BE SLOPED AWAY AT A MINIMUM OF 5% (0.5' OF DROP) FOR THE FIRST 10'.
- *CENTER OF CITY STREET AND TOP OF CURB ELEVATIONS
- *PROPOSED DRIVE/ROAD GRADE IN % SLOPE (MINIMUM 2%, NOT TO EXCEED 10%)
- *LOWEST FLOOR, LOWEST OPENING, TOP OF FOUNDATION, AND GARAGE FLOOR ELEVATIONS
- *DRAINAGE DIRECTION ARROWS ON ALL SIDES AND PROPOSED DRAINAGE PATHS
- *DRAINAGE OUTLETS, OUTLET CONTROL STRUCTURES, AND EMERGENCY OVERFLOWS
- *TOTAL AREA OF EXISTING AND PROPOSED IMPERVIOUS SURFACE
- *WATER BODIES ID AND ELEVATIONS SHOWING NORMAL WATER LEVEL, HIGH WATER LEVEL, FLOODWAY, FLOODPLAIN, AND ORDINARY HIGH WATER LEVEL ELEVATIONS
- *UTILITY PEDESTALS (GRADING AS-BUILT ONLY)
- *TREES (GRADING AS-BUILT ONLY)
- *TOP AND BOTTOM OF RETAINING WALL ELEVATIONS

ELEVATIONS MUST BE SHOWN AS SEA LEVEL MEASUREMENTS. FOR AS-BUILT CONSTRUCTION AND GRADING SURVEYS, ELEVATIONS MUST BE CROSS-REFERENCED WITH APPROVED ELEVATIONS.

MINIMUM REQUIRED BUILDING ELEVATIONS

BUILDING OPENINGS AND FLOOR ELEVATIONS

ALL OPENINGS AND FLOOR ELEVATIONS MUST BE CONSTRUCTED AT LEAST TWO (2) FEET ABOVE 100-YEAR FLOOR ELEVATION AND TWO (2) FEET ABOVE HIGHEST ANTICIPATED WATER LEVEL (HWL) ELEVATION AS ESTABLISHED BY THE APPROVED PLANS AND THE CITY ENGINEER.

BUILDING AND GARAGE OPENINGS

ALL LOW ADJACENT GRADE AND GARAGE FLOOR ELEVATIONS MUST BE AT LEAST ONE (1) FOOT ABOVE ALL EMERGENCY OVERFLOWS.

THIS INFORMATIONAL DOCUMENT MAY NOT COMPREHENSIVELY ADDRESS ALL LAWS RELATED TO THE SUBJECT ADDRESSED. IT IS PROVIDED TO SERVE ONLY AS A HELPFUL GUIDE. SITE PREPARATION OR PERMITTED WORK IS NOT ALLOWED UNTIL PERMITS HAVE BEEN ISSUED BY THE CITY OF DAYTON.



2026 DETAIL PLATES
REV.1

**CERTIFICATE OF SURVEY AND
GRADING AS-BUILT REQUIREMENTS**

LAST REVISION:
DEC 2024

PLATE NO.
GEN-15